



PART B – CITY OF ROCKINGHAM

1. Declarations of Due Consideration

2. Disclosure of Interests

3. Form 1 DAP Applications

Nil

4. Form 2 DAP Applications

4.1 Lot 622 (No.2) Aurea Boulevard, Golden Bay - Proposed mixed commercial development (Golden Bay Neighbourhood Centre) – DAP/24/02447

5. Section 31 SAT Reconsiderations

Nil

**Part B – Item 4.1 - LOT 622 (No.2) AUREA BOULEVARD,
GOLDEN BAY – REQUEST TO AMEND DEVELOPMENT
APPROVAL (GOLDEN BAY NEIGHBOURHOOD CENTRE) –
AMEND LIQUOR STORE TO MOTOR VEHICLE WASH**

**Form 2 – Responsible Authority Report
(Regulation 17)**

DAP Name:	Metro Outer Development Assessment Panel
Local Government Area:	City of Rockingham
Proposed Amendments:	Change of land use from 'Liquor Store' to 'Motor Vehicle Wash' in a similar overall layout and site configuration
Applicant:	Marc Re, Planning Solutions
Owner:	Golden Bay WA Properties Pty Ltd
Value of Amendment:	\$ 1.5 million
Responsible Authority:	City of Rockingham
Authorising Officer:	Mr Mike Ross, Manager Statutory Planning
LG Reference:	DD020.2025.00000175.001
DAP File No:	DAP/23/02447
Date of Original DAP decision:	20 March 2024
Application Received Date:	14 May 2025
Application Statutory Process Timeframe:	90 Days
Attachment(s):	1. Development Plans 2. Schedule of Submissions 3. Original Determination dated 20 March 2024

Responsible Authority Recommendation

That the Metro Outer Development Assessment Panel resolves to:

- Accept** that the DAP Application reference DAP/23/02447 as detailed on the DAP Form 2 dated 14 May 2025 is appropriate for consideration in accordance with regulation 17 of the *Planning and Development (Development Assessment Panels) Regulations 2011*; and
- Approve** DAP Application reference DAP/23/02447 and accompanying plans in accordance with Clause 68 of Schedule 2 (Deemed Provisions) of the *Planning and Development (Local Planning Schemes) Regulations 2015*, and the City of Rockingham Town Planning Scheme No. 2, for the proposed amendment to the approved Mixed Commercial development (Golden Bay Neighbourhood Centre) dated 20 March 2024 at No.2 Aurea Boulevard Golden Bay, subject to the following conditions:

Amended Conditions

- Existing Condition No.2 to be modified to include reference to the following plans:

- DA01 – Locality Plan (Proposed Car Wash), revision M dated 13 August 2025;
 - DA02 – Site Plan (Proposed Car Wash), revision J dated 13 August 2025;
 - DA03 – Floor Plan (Proposed Car Wash), revision E dated 11 August 2025;
 - DA04 – Elevations (Proposed Car Wash), revision B dated 6 March 2025;
 - DA05 – Elevations (Proposed Car Wash), dated 1 February 2025;
 - DA06 – Elevations (Proposed Car Wash), dated 1 February 2025;
 - DA08 – Elevations (Proposed Car Wash), dated 1 February 2025; and
 - L-01 – Planting Plan and Schedule, revision B dated 12 August 2025.
2. Existing Condition No.7(ii) which reads as follows:

- (ii) *A solid screen wall to be constructed in the vicinity of the Liquor Store bin area fronting Warnbro Sound Avenue, of minimum height 1.6m and of minimum surface mass of 4kg/m², and be free of gaps, as shown on the approved plans. The screening to be of a masonry construction and of a suitable design complementing the overall development, as illustrated in the Material Schedule, to ensure an attractive appearance to Warnbro Sound Avenue and internal to the site to the satisfaction of the City of Rockingham, having regard to the high level of visibility of the screen wall to Warnbro Sound Avenue.*

to be deleted as the Liquor Store use has been removed from the development.

New Conditions

1. Prior to applying for a Building Permit for the Motor Vehicle Wash, an Acoustic Report prepared by a suitably qualified acoustic consultant and demonstrating compliance with the *Environmental Protection (Noise) Regulations 1997*, must be submitted to and approved by the City of Rockingham. The acoustic report shall, at a minimum but not be limited to, addressing mechanical plant elements and any attenuation measures required.
2. The Motor Vehicle Wash development must comply with the requirements and recommendations of the Lloyd George Acoustics report dated 27 June 2025 (ref. 24119644-01A) and shall incorporate:
 - (i) A five metre high solid screening wall to the west end of car wash building, as shown on the approved plans;
 - (ii) Vacuum centrifugal system with no more than 90 dB(A) sound power level and with full perimeter fencing of 1.8m in height and 8kg/m² surface mass or greater that seals at ground. Exhaust flue must not protrude beyond the fence height;
 - (iii) Auto wash bays being fitted with automated RL3500 doors, at entry and exit achieving acoustic performances of Rw19 dB or greater. Both doors are to be programmed to close during 7pm to 7am Monday to Saturday, and 7pm to 9am Sundays and Public Holidays;
 - (iv) Plant room roller door to remain shut when the car wash is operating between 7pm to 7am Monday to Saturday, and 7pm to 9am Sundays and Public Holidays. Door may be opened for periods during the day where required for maintenance access.

3. Prior to the occupation of the Motor Vehicle Wash development written confirmation shall be provided from a suitably qualified acoustic consultant confirming that all requirements indicated in the Lloyd George Acoustics report dated 27 June 2025 (ref. 24119644-01A) have been incorporated into the development.
4. Prior to applying for a Building Permit for the Motor Vehicle Wash development, a bin storage area must be:
 - (a) designed with a size suitable to service the development and be screened from view of the street, or the internal service road to the satisfaction of the City of Rockingham; and
 - (b) constructed prior to the occupation of the development and must be retained and maintained in good condition for the duration of the Development.
5. Prior to the occupation of the Motor Vehicle Wash development, the car wash bays must be constructed of hard-stand, bunded, graded, roofed and be serviced by a petrol and oil separator suitable for connection to Water Corporation sewer mains.

Wash bays, including petrol and oil separators, must be maintained to the satisfaction of the City of Rockingham for the duration of the development.

6. The Motor Vehicle Wash and ancillary offerings are restricted to the following operating hours:
 - Automated Motor Vehicle Wash - 7:00am to 8:00pm, seven days a week;
 - Vacuum system associated with the Motor Vehicle Wash
 - 7:00am to 8:00pm Monday to Saturday;
 - 9:00am to 7:00 pm Sundays and/or Public Holidays;
 - Dog Wash facility
 - 7:00am to 8:00pm Monday to Saturday;
 - 9:00am to 7:00 pm Sundays and/or Public Holiday

Amended Advice Notes

1. Existing Advice Note 7 which reads as follows:

The Liquor Store is to comply with the Liquor Control Act 1988, all relevant approvals and licenses are to be sought prior to the occupation of the development in conjunction with the Department of Local Government, Sport and Cultural Industries.

being deleted as it is no longer relevant.

New Advice Notes

1. In regards to Condition 6 of the existing Development Approval dated 20 March 2024, the intended one-way traffic flow for the Motor Vehicle Wash development being shown via pavement marking.

All other conditions and requirements detailed on the original Development Approval dated 20 March 2024 shall remain.

Details: outline of development application

Region Scheme	Metropolitan Region Scheme
Region Scheme Zone/Reserve	Urban
Local Planning Scheme	City of Rockingham Town Planning Scheme No.2
Local Planning Scheme Zone/Reserve	Commercial
Structure Plan/Precinct Plan	Golden Bay Neighbourhood Centre
Structure Plan/Precinct Plan Land Use Designation	Commercial
Use Class (proposed) and permissibility:	Motor Vehicle Wash - Discretionary ('D')
Lot Size:	1.2398ha
Net Lettable Area (NLA):	162m ²
Number of Dwellings:	N/A
Existing Land Use:	Vacant land
State Heritage Register	No
Local Heritage	<input checked="" type="checkbox"/> N/A <input type="checkbox"/> Heritage List <input type="checkbox"/> Heritage Area
Design Review	<input checked="" type="checkbox"/> N/A <input type="checkbox"/> Local Design Review Panel <input type="checkbox"/> State Design Review Panel <input type="checkbox"/> Other
Bushfire Prone Area	No
Swan River Trust Area	No

Proposal:

The proposal seeks to amend a portion of the approved Golden Bay Neighbourhood Centre (GBNC) development to replace the approved Liquor Store tenancy with a drive through car wash in a similar overall layout and site configuration.

Specifically, the proposed amendment comprises the following:

- Automatic drive-thru car wash facility with nine (9) vacuum bays provided central to the site;
- Ancillary dog wash facility within the central car parking area;
- Change to trading hours for the proposed Motor Vehicle Wash facility being 7am to 8pm, seven (7) days per week, in lieu of the approved hours of 9am to 10pm for the Liquor Store, seven days per week;
- Relocation of waste storage areas and change to landscaping treatments to reflect the revised layout.

The following images show the approved GBNC development layout and the proposed change (refer RAR Attachment 3 for further detail).

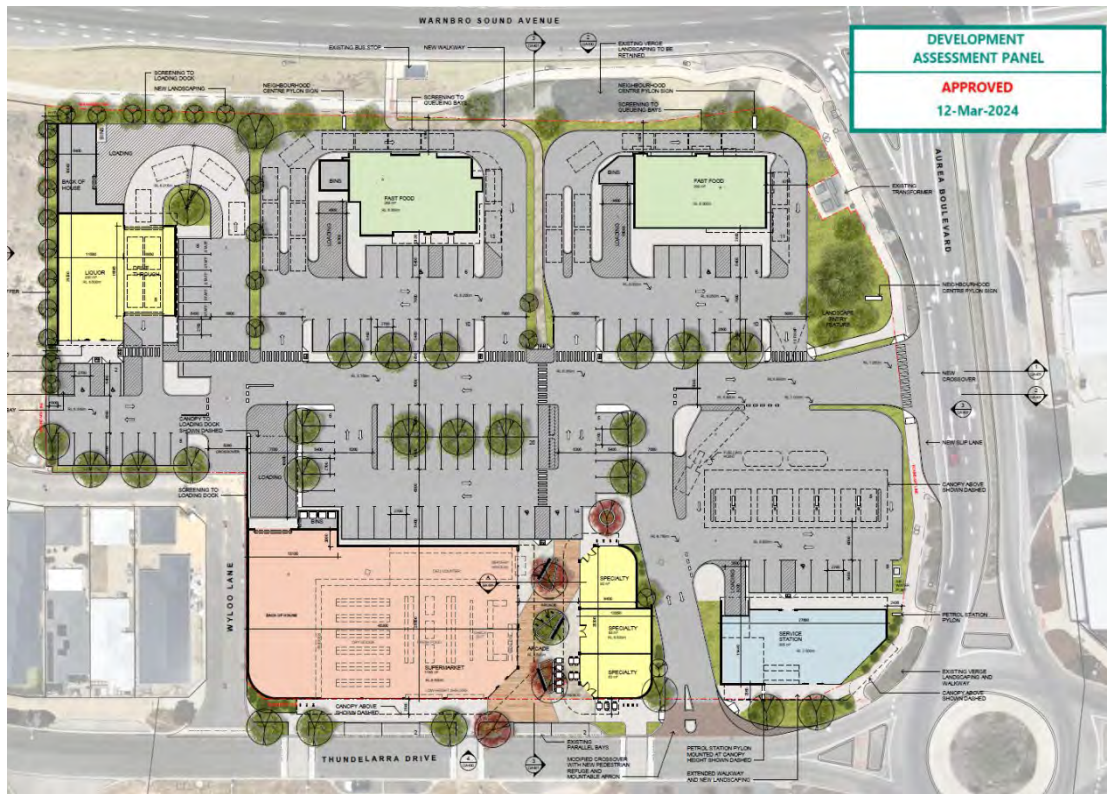

Background:

The Metro Outer Development Assessment Panel (MODAP) at its meeting held on 12 March 2024, resolved to reconsider the decision for Development Approval for a Mixed Commercial development, known as the Golden Bay Neighbourhood Centre (GBNC), on the subject site, and issue Development Approval pursuant to section 31 of the *State Administration Tribunal Act 2004*. [12 March 2024 - Minutes - No 3 - City of Rockingham](#)

Figure 1. Approved GBNC development layout

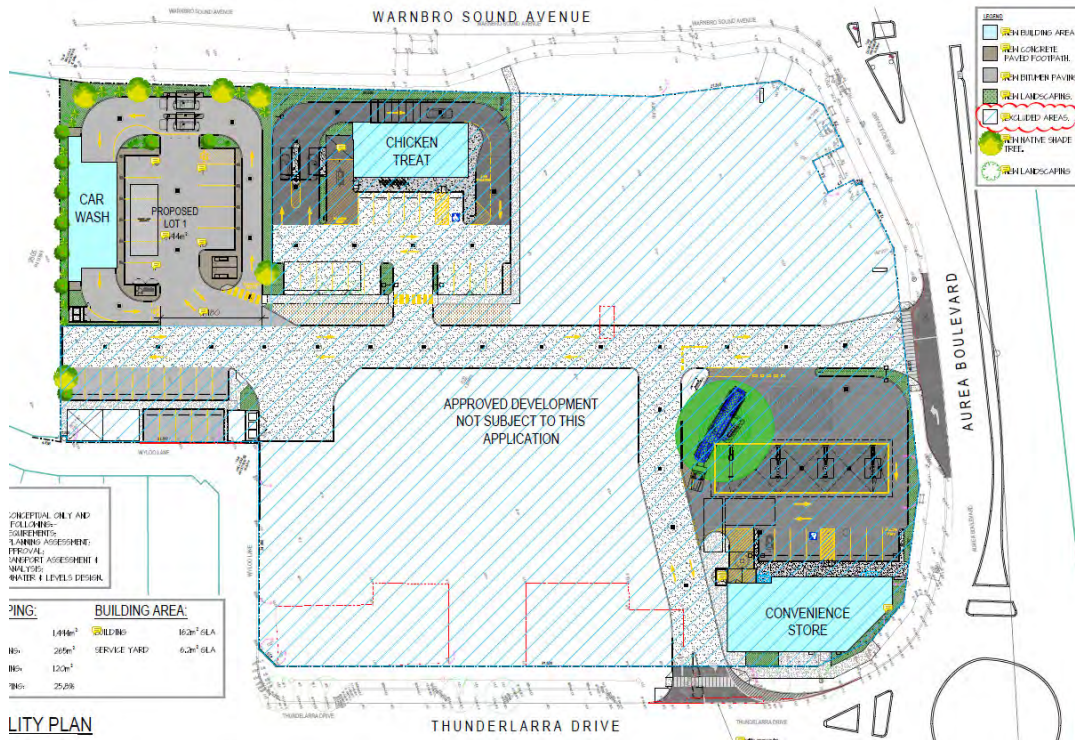

Figure 2. Proposed change showing proposed Motor Vehicle Wash development

Site Context

The subject site is located within the GBNC, approximately 1km south of the Secret Harbour District Centre. (See Figure 3)

The site is located centrally to the Golden Bay Structure Plan area, and to the Neighbourhood Centre itself, and is bound by Warnbro Sound Avenue to the east, Thundelarra Drive to the west (as the ‘Main Street’ for the Centre), and Aurea Boulevard to the south.

The northern boundary of the site abuts a Residential ‘R60’ lot with Development Approval issued by the MODAP in May 2025 for a Child Care Premises. The north-west comprises a number of laneway style residential dwellings constructed along Wyloo Lane.

Two (2) operating Child Care Premises are located to the immediate west and south-west of the subject site. A Primary School is located 200m to the south-west of the subject site. To the immediate east, fronting Warnbro Sound Avenue, MODAP issued Development Approval in December 2024 for two (2) Fast Food Outlets, currently under construction. A Service Station, with other commercial uses, is operating to the south. (see Figure 4)

Other land surrounding the GBNC has largely been developed for residential purposes.

The GBNC as approved includes eight (8) commercial tenancies across the site, including a Supermarket, Service Station, two (2) Fast Food Outlets, three (3) speciality

retail and a drive through liquor store. A separate Form 2 DAP amendment has been lodged over the site with the City more recently which seeks to reconfigure the layout of the approved supermarket (with a different operator), and the associated individual tenancies.

Construction of the Service Station and one (1) of the Fast Food Outlets has commenced on site.

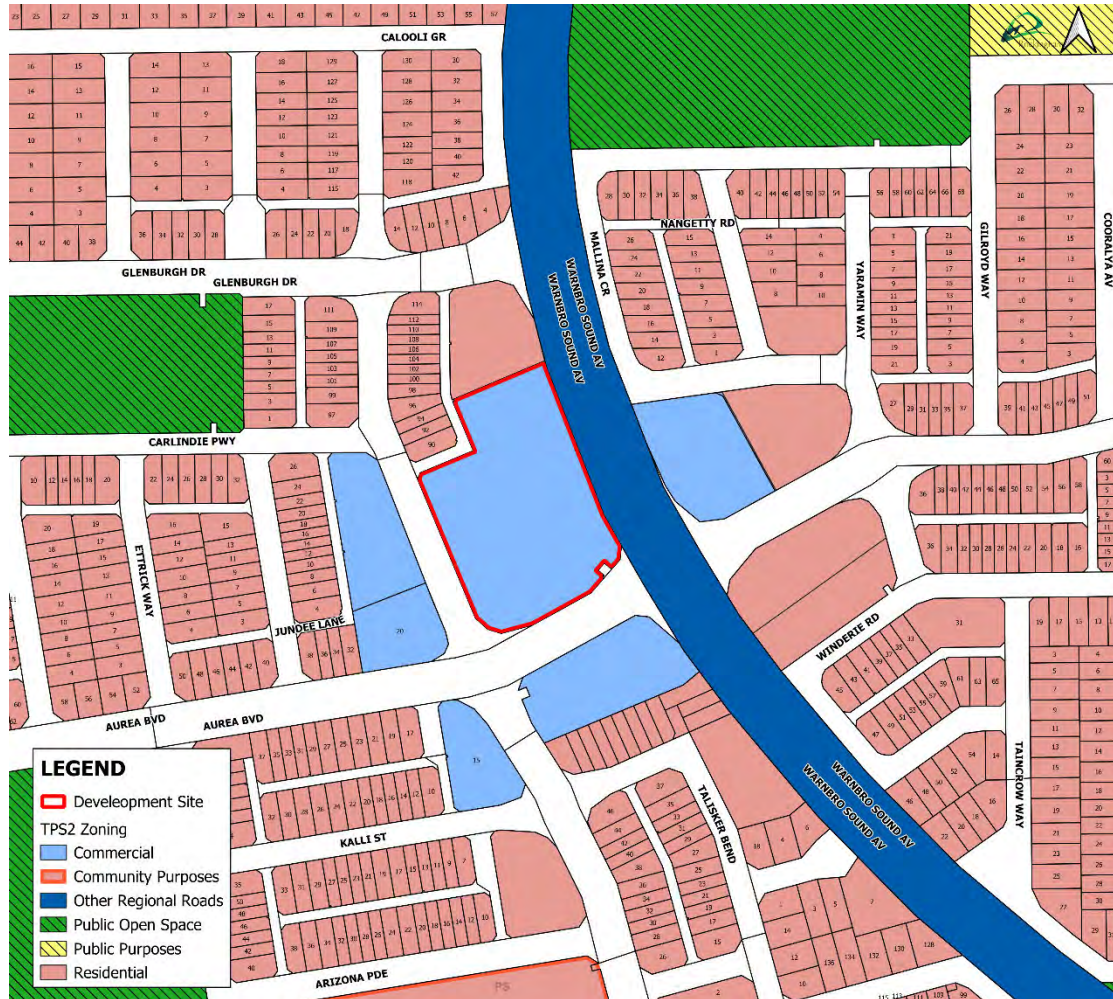

Figure 3. Zoning Map



Figure 4. Location Plan

Legislation and Policy:

Legislation

Planning and Development (Local Planning Schemes) Regulations 2015 (the Regulations)
 City of Rockingham Town Planning Scheme No.2 (TPS2)
 Environmental Protection (Noise) Regulations 1997 (EPNR)

State Government Policies

State Planning Policy 4.2 – Activity Centres (SPP4.2)
 State Planning Policy 7.0 – Design of the Built Environment (SPP7.0)

Local Development Plan

Golden Bay Neighbourhood Centre Local Development Plan (2022)

Local Policies

Planning Policy No.3.3.1 - Control of Advertisements (PP3.3.1)
 Planning Policy No.3.3.14 - Bicycle Parking and End-of-Trip Facilities (PP3.3.14)

Consultation:

Public Consultation

The proposal, was advertised for public comment for a period of 17 days between 3 June - 20 June 2025, in accordance with Clause 64, Schedule 2 of the *Planning and Development (Local Planning Schemes) Regulations 2015*, and Local Planning Policy No.3.3.27 - Community Consultation for Development Applications.

Advertising was carried out as follows:

- All owners and occupiers identified within 200m of the subject site were notified in writing of the proposed development; and
- The application was made available for public inspection at the City's Administration Offices, and published on the City's website.

At the close of the public consultation period, a total of two (2) public submissions were received objecting to the proposal. Figure 5 below depicts the consultation area and the location of the submissions received.



Figure 5. Consultation Map

The following table identifies the submission issues raised and the City's response :

Issue Raised	Officer's comments
Noise	<p>The City has reviewed the applicants submitted Environmental Noise Assessment (ENA) and accepts the conclusions. The ENA has considered noise emissions from the proposed development to surrounding properties by way of noise modelling of mechanical plant, autowash bays, vehicles and vacuum units. The following noise mitigation measures are recommended in the ENA to be included as new conditions:</p> <ul style="list-style-type: none"> • 5-metre high solid screening wall to the west end of car wash building, as shown on DA plans, being the northern wall of the proposed Motor Vehicle Wash structure; • Vacuum centrifugal system with no more than 90 dB(A) sound power level and with full perimeter fencing of 1.8m in height and 8kg/m² surface mass or greater that seals at ground. Exhaust flue must not protrude beyond the fence height; • Auto wash bays fitted with automated RL3500 doors, at entry and exit achieving acoustic performances of Rw19 dB or greater. Both doors are to be programmed to close during 7pm to 7am Monday to Saturday, and 7pm to 9am Sundays and Public Holidays; • Plant room roller door to remain shut when the car wash is operating between 7pm to 7am Monday to Saturday, and 7pm to 9am Sundays and Public Holidays. Doors may be opened for short periods during the day where required for maintenance access. <p>The City also recommends that conditions be amended to reflect the hours of operation.</p>
Traffic Congestion	<p>The submitted queue analysis demonstrates that the estimated vehicle queue will not exceed a queue length of five vehicles 95% of the time. It is therefore concluded that under typical peak conditions, a queue of five (5) vehicles (i.e. five cars waiting in the queue) during the peak operation period of the carwash can be accommodated within the development site with no impact on the internal service road of the GBNC development, or more broadly the external surrounding traffic network. The image below confirms the queuing capacity within the development site.</p>

	
<p>Environmental Impacts</p>	<p>The proposed Motor Vehicle Wash facility will integrate into the wider drainage network for the GBNC. To ensure wastewater is managed appropriately, the following conditions are recommend to be included</p> <ul style="list-style-type: none"> • Prior to the occupation of the development, the car wash bays must be constructed to the satisfaction of the City of Rockingham. The wash bays must be constructed of hard-stand, bunded, graded, roofed and be serviced by a petrol and oil separator suitable for connection to Water Corporation sewer mains. • Wash bays, including petrol and oil separators, must be maintained for the duration of the development.
<p>Public Consultation Process</p>	<p>Advertising was completed in accordance with Clause 64, Schedule 2 of the <i>Planning and Development (Local Planning Schemes) Regulations 2015</i>. For consistency, the City applied the same consultation area as that used for the initial GBNC Development Application.</p>

Submissions received are contained within Attachment 2 to this Report.

Referrals/consultation with Government/Service Agencies

Not Applicable

Design Review Panel Advice

Not Applicable

Swan Valley Planning

Not Applicable

Other Advice

Clause 77(c) of the *Planning and Development (Local Planning Schemes) Regulations 2015*, enables an application requesting an amendment to Development Approval which does not substantially change the development approved. In this respect, the Motor Vehicle Wash is similar to the approved Drive Through Liquor Store in relation to building scale, orientation and while it involves a different land use, with the proposed noise control measures in place it is unlikely to cause interference with residential amenity.

Planning Assessment:

The proposal is generally consistent with the intent of the GBNC Development Approval and the statements associated with the Local Development Plan (LDP) informing the design and landscape outcomes. The land use provides a commercial component, and the design has considered the orientation to maintain a street interface to Warnbro Sound Avenue with delivery, storage and service areas screened at the rear. The proposal is therefore considered to align with the underlying development approval.

The following variation noted as outlined below:

Provision	Requirement	Proposal	Assessment
TPS2 – clause 4.6.4(a)	Where a development is proposed to be located on a lot having a common boundary with a Residential zoned lot or residential use class, the setbacks shall not be less than those prescribed in the R-Codes for the particular density code of the adjoining residential lot	A setback of 1.49m to the northern boundary is proposed, at a height of 5m for a total length of 29.56m(24.56m for the wall of the vehicle wash facility, and 5m for an acoustic wall)	The adjoining lot to the north is zoned residential R60, with a lot boundary setback requirement of 1.5m for a height of 3.6m to 7m pursuant to the R-Codes. The variation relates that part of the wall above 3.6m in height, and exceedance of the 14m in length requirement at a setback of 1.49m. The existing approval cited the Liquor Store development at a distance of 1.88-2.11m along the northern boundary, for a length of 36.25m.

			<p>The change to the setback for the Motor Vehicle wash is considered acceptable for the following reasons:</p> <ul style="list-style-type: none">• The length of wall presented to the northern boundary has been reduced, particularly that extending toward Warnbro Sound Avenue;• The length of wall is appropriate to the height and design of the facility to screen and enclose the plant room for noise mitigation purposes;• The setback allows for six (6) trees to be planted to assist in reducing the visual appearance of the wall consistent with the approved landscape strategy for the GBNC;• The adjoining portion of the site where the wall of the facility is proposed, whilst designated as residential, has received Development Approval and a Building Permit for a Child Care Premises. As such the intended use of the site
--	--	--	--

			<p>has changed to a commercial use;</p> <ul style="list-style-type: none"> • The extension of the wall for 5m beyond the built form of the wash facility provides further noise mitigation to future development on the northern lot <p>The impacts and build form is a slight variation to that approved, however the variation is considered to be an improvement.</p>
--	--	--	---

Noise Impacts

A detailed assessment of the acoustic impacts of the proposal has been undertaken to ensure that matters raised on the public submissions and the amenity considerations of adjacent owners are addressed, such that the proposal is likely to comply with the EPNR.

The submitted ENA has considered noise emissions from the proposed development to surrounding properties by way of noise modelling of mechanical plant, automatic wash bays, vehicles and vacuum units. A number of recommendations from the ENA including installation of an acoustic wall and rollers doors on the automatic wash bay, have been presented to mitigate noise to achieve compliance with the EPNR. These mitigation measures are recommended to be imposed as a separate and specific conditions to ensure they are implemented in the design and operational phases of the development. Figure 6 depicts the Motor Vehicle Wash facility in context of the northern allotment and the acoustic wall extent, and Figure 7, extracted from Attachment 1, shows the proposed elevation.



Figure 6. Extent of Acoustic Wall to Northern aspect



Figure 7. North Elevation

It is noted from the ENA that compliance is marginal during the night time period (after 7pm) and being prior to 9am on Sundays and Public Holidays for the vacuum system and dog wash facilities. As such, the City recommends that a condition for the hours of operation based on the Applicant's submission and supporting ENA also be imposed as follows:

The Motor Vehicle Wash and ancillary offerings are restricted to the following hours:

- Automated Motor Vehicle Wash - 7:00am to 8:00pm, seven days a week;
- Vacuum system associated with the Motor Vehicle Wash
 - 7:00am to 8:00pm Monday to Saturday;
 - 9:00am to 7:00 pm Sundays and/or Public Holidays;

- Dog Wash facility
 - 7:00am to 8:00pm Monday to Saturday;
 - 9:00am to 7:00 pm Sundays and/or Public Holiday

Conclusion:

The proposed development presents a land use and built form consistent with the Commercial zoning and the existing GBNC design intent. The development is orientated to face the Warnbro Sound Avenue frontage, providing an active yet open frontage. The bulk of the built form is cited to the northern boundary, which ensures an openness to the Warnbro Sound Avenue and frames the GBNC development site.

The landscaping proposal is consistent with the landscape strategy for the GBNC, with specific planting requirements included in updated plans, this will ensure that the specified tree species are established to achieve the specific screening requirements.

With regards to advertising signage, the existing development approval specified signage types and locations for the Liquor Store. A revised signage proposal specific to the Motor Vehicle Wash has been presented and is considered generally consistent in terms of intent and types of signage to that approved for the Liquor Store as part of the GBNC approval. The signage proposal is considered appropriate to the locality, provides visual interest, and is commensurate to the type and scale of the building proposed.

Whilst the TPS2 does not specify a car parking rate applicable to a Motor Vehicle Wash, the submitted queue analysis indicates that the proposed development, at peak operation, can accommodate vehicles within the site and will not impact traffic movement or safety internal to the GBNC development or the surrounding road networks.

As a complete development, the existing approval allocated 32 queuing bays combined to the Fast Food Outlet and Liquor Store drive throughs. Reference to the approved plans indicates four (4) queuing bays and nine (9) on site car parking bays within the vicinity of the tenancy. The Motor Vehicle Wash provides an excess of queuing bays and 10 bays for patrons on the site. As such, the car parking allocation is sufficient and consistent with the existing approval.

The proposal is generally compliant with the City of Rockingham Town Planning Scheme No.2 and is considered to be aligned with the existing Development Approval for the purposes of the GBNC and the conditions be amended as outlined in this report.

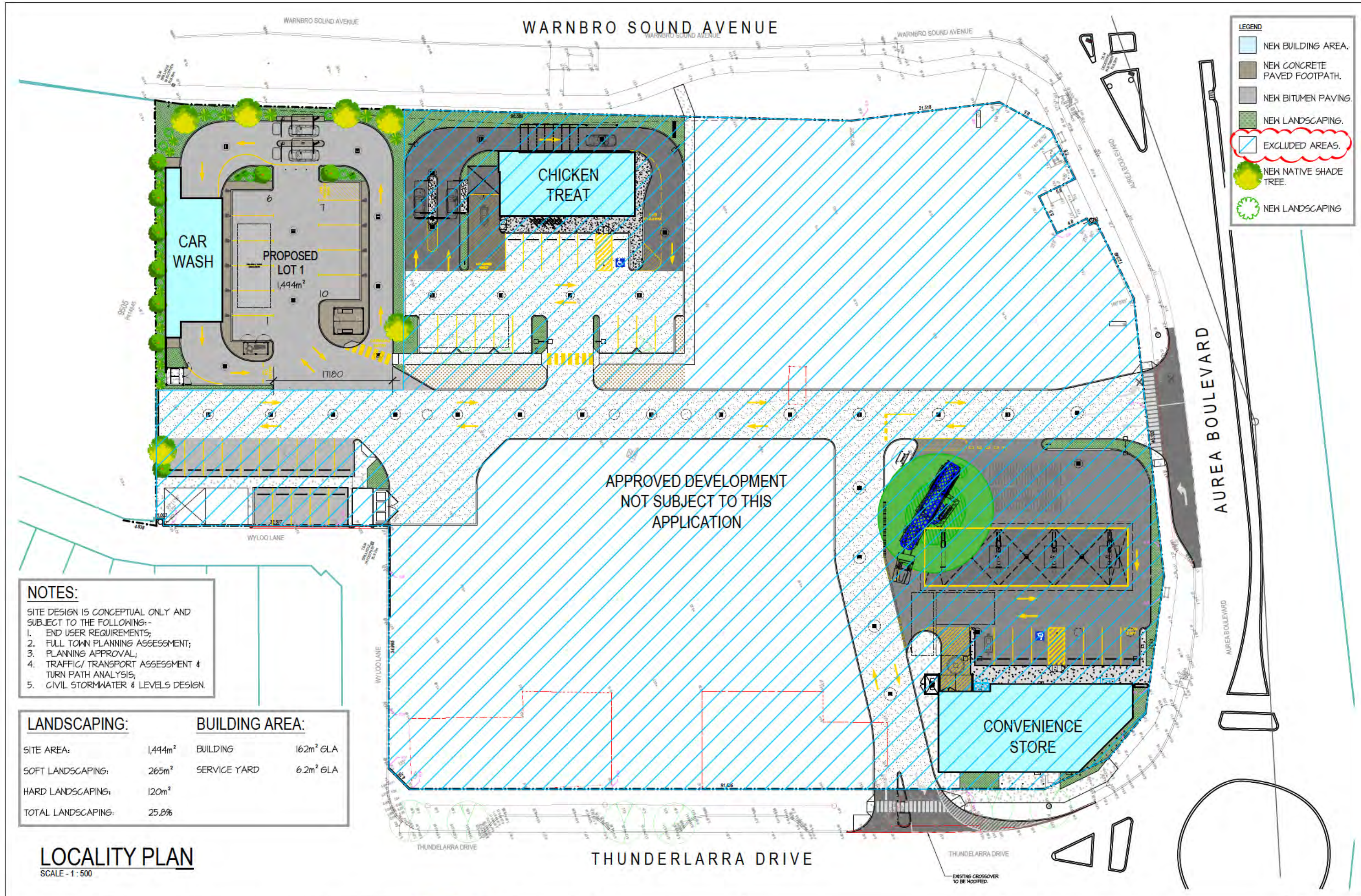

LEGEND

- NEW BUILDING AREA.
- NEW CONCRETE PAVED FOOTPATH.
- NEW BITUMEN PAVING.
- NEW LANDSCAPING.
- EXCLUDED AREAS.
- NEW NATIVE SHADE TREE.
- NEW LANDSCAPING

NOTES:
 SITE DESIGN IS CONCEPTUAL ONLY AND SUBJECT TO THE FOLLOWING:-
 1. END USER REQUIREMENTS;
 2. FULL TOWN PLANNING ASSESSMENT;
 3. PLANNING APPROVAL;
 4. TRAFFIC/ TRANSPORT ASSESSMENT & TURN PATH ANALYSIS;
 5. CIVIL STORMWATER & LEVELS DESIGN.

LANDSCAPING:		BUILDING AREA:	
SITE AREA:	1,444m ²	BUILDING	162m ² GLA
SOFT LANDSCAPING:	265m ²	SERVICE YARD	6.2m ² GLA
HARD LANDSCAPING:	120m ²		
TOTAL LANDSCAPING:	25.8%		

LOCALITY PLAN
 SCALE - 1 : 500

THIS DRAWING IS COPYRIGHT AND MUST NOT BE RETAINED, COPIED OR USED WITHOUT AUTHORITY OF HORLEY BUILDING DESIGN & DRAFTING. DO NOT SCALE FROM THIS DRAWING. THE CONTRACTOR AND HIS SUBCONTRACTORS ARE TO VERIFY ALL DIMENSIONS ON SITE BEFORE MAKING SHOP DRAWINGS OR COMMENCING MANUFACTURE. THIS IS A COMPUTER GENERATED DRAWING AND SHALL NOT BE ALTERED BY HAND.

NO.	DATE	REVISION	DRAWN	CHECK
F	05.05.25	REVISED AS PER COMMENTS	U	-
G	19.06.25	REVISED AS PER COMMENTS	U	-
H	22.06.25	REVISED AS PER COMMENTS	U	-
I	23.06.25	REVISED AS PER COMMENTS	U	-
J	24.06.25	REVISED AS PER COMMENTS	U	-
K	25.06.25	REVISED AS PER TRAFFIC ENG COMMENTS	U	-
L	11.08.25	REVISED AS PER COMMENTS	U	-
M	13.08.25	REVISED AS CLOUDED	U	-



DEVELOPMENT APPLICATION

PROPOSED CAR WASH
 LOT 1, No. 2 AUREA BOULEVARD
 GOLDEN BAY
 for SARACEN PROPERTIES

A3 SHEET

Date	01.02.25
Design	U
Drawn	U
Checked	U
Scale	1:500
Job No.	86043
Dwg -	DA01
Rev -	M

WARNBRO SOUND AVENUE

WYLOO LANE

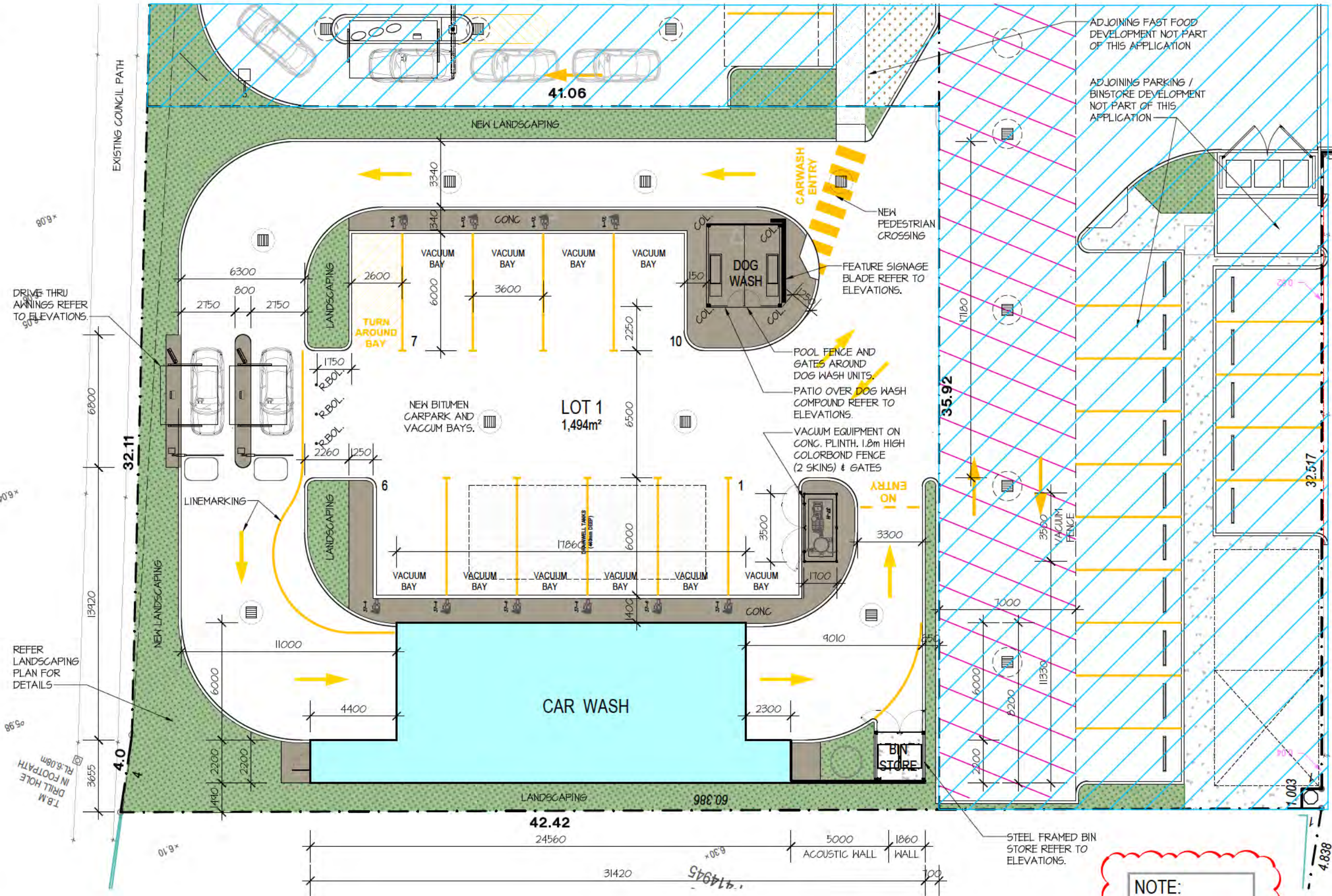

SITE PLAN
SCALE - 1 : 200

NOTE:
 EXCLUDED AREAS.

THIS DRAWING IS COPYRIGHT AND MUST NOT BE RETAINED, COPIED OR USED WITHOUT AUTHORITY OF HORLEY BUILDING DESIGN & DRAFTING. DO NOT SCALE FROM THIS DRAWING. THE CONTRACTOR AND HIS SUBCONTRACTORS ARE TO VERIFY ALL DIMENSIONS ON SITE BEFORE MAKING SHOP DRAWINGS OR COMMENCING MANUFACTURE. THIS IS A COMPUTER GENERATED DRAWING AND SHALL NOT BE ALTERED BY HAND.

NO.	DATE	REVISION	DRAWN	CHECK
C	24.02.25	REVISED AS PER COMMENTS	U	U
D	06.03.25	REVISED AS PER COMMENTS	U	U
E	19.06.25	REVISED AS PER COMMENTS	U	U
F	22.06.25	REVISED AS PER COMMENTS	U	U
G	24.06.25	REVISED AS PER COMMENTS	U	U
H	25.06.25	REVISED AS PER TRAFFIC ENG COMMENTS	U	U
I	11.08.25	REVISED AS PER COMMENTS	U	U
J	13.08.25	REVISED CLOUDED	U	U



DEVELOPMENT APPLICATION

PROPOSED CAR WASH
LOT 1, No. 2 AUREA BOULEVARD
GOLDEN BAY
for SARACEN PROPERTIES

A3 SHEET Date 31.01.25
 Design U
 Drawn U
 Checked U
 Scale 1:200
 Job No. 88043
 Dwg. **DA02**
 Rev - J

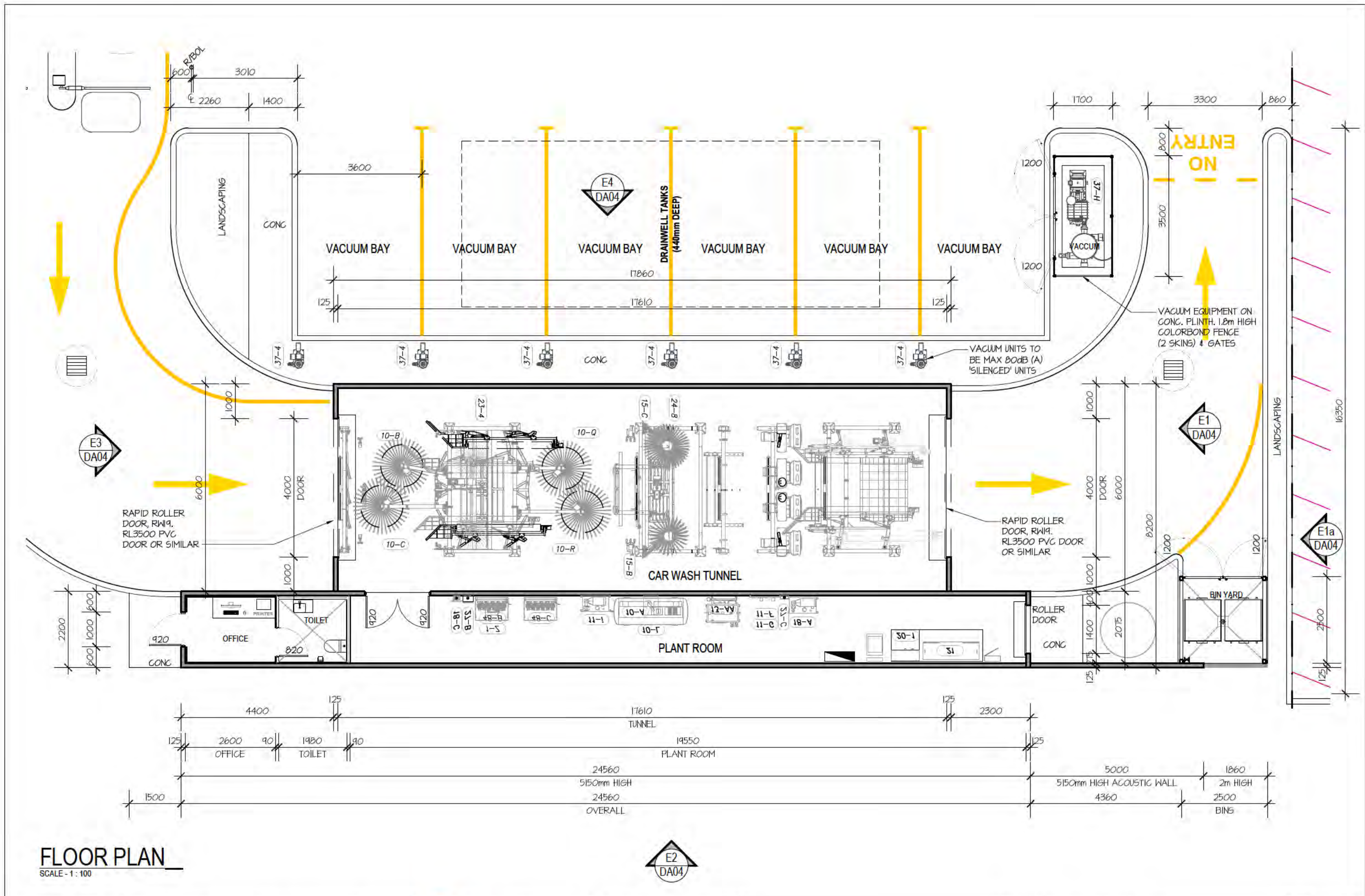

FLOOR PLAN
SCALE - 1 : 100

THIS DRAWING IS COPYRIGHT AND MUST NOT BE RETAINED, COPIED OR USED WITHOUT AUTHORITY OF HORLEY BUILDING DESIGN & DRAFTING. DO NOT SCALE FROM THIS DRAWING. THE CONTRACTOR AND HIS SUBCONTRACTORS ARE TO VERIFY ALL DIMENSIONS ON SITE BEFORE MAKING SHOP DRAWINGS OR COMMENCING MANUFACTURE. THIS IS A COMPUTER GENERATED DRAWING AND SHALL NOT BE ALTERED BY HAND.

NO.	DATE	REVISION	DRAWN	CHECK
A	02.02.25	REVISED AS PER COMMENTS	U	U
B	24.02.25	REVISED AS PER COMMENTS	U	U
C	06.03.25	REVISED AS PER COMMENTS	U	U
D	23.06.25	REVISED AS PER COMMENTS	U	U
E	11.08.25	REVISED AS PER COMMENTS	U	U



DEVELOPMENT APPLICATION

PROPOSED CAR WASH
LOT 1, No. 2 AUREA BOULEVARD
GOLDEN BAY
for SARACEN PROPERTIES

A3 SHEET
Date 31.01.25
Design U
Draw U
Checked U
Scale 1:100
Job No. B5043
Dwg. **DA03**
Rev. **E**

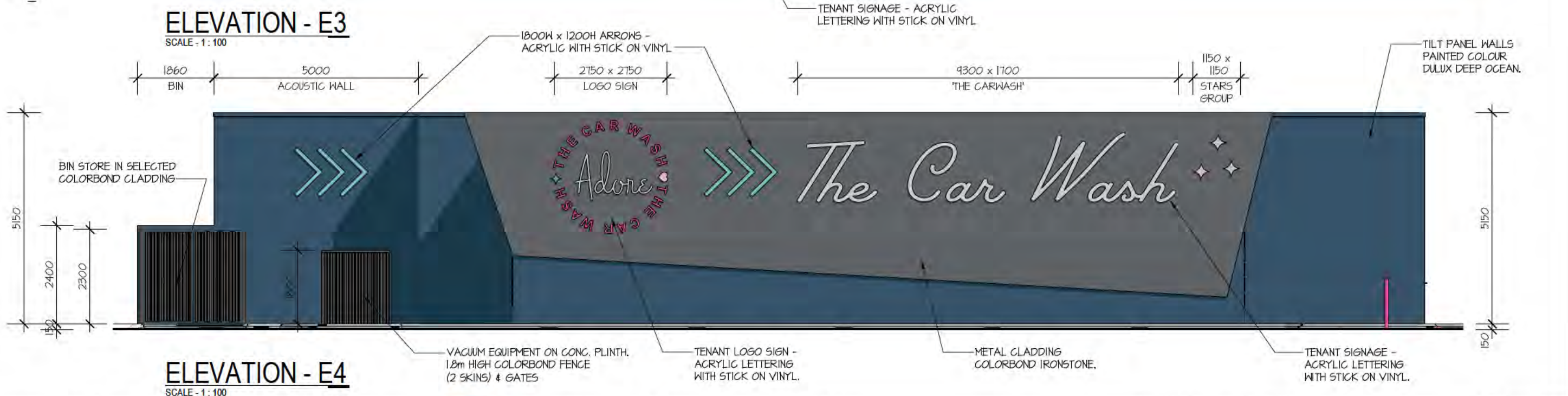
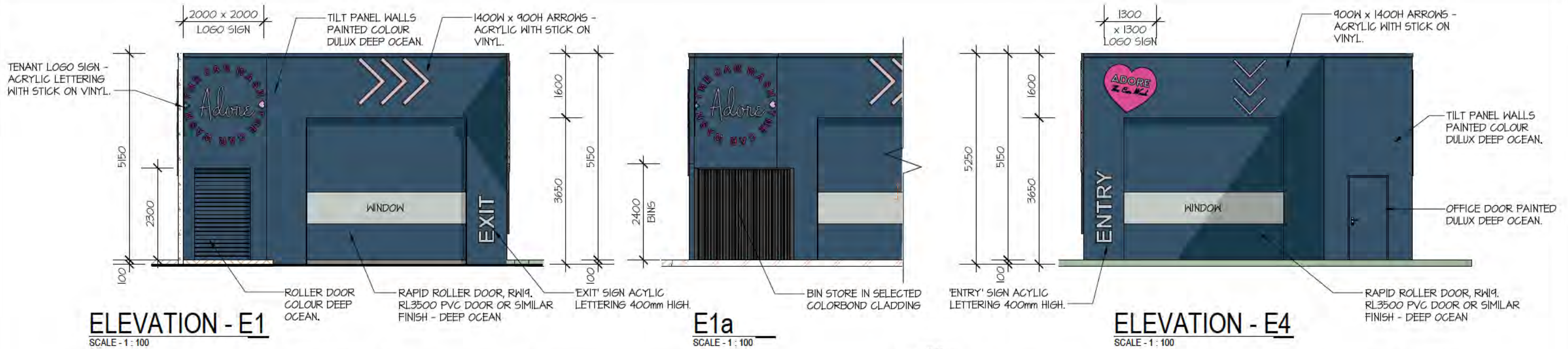

THIS DRAWING IS COPYRIGHT AND MUST NOT BE RETAINED, COPIED OR USED WITHOUT AUTHORITY OF HORLEY BUILDING DESIGN & DRAFTING. DO NOT SCALE FROM THIS DRAWING. THE CONTRACTOR AND HIS SUBCONTRACTORS ARE TO VERIFY ALL DIMENSIONS ON SITE BEFORE MAKING SHOP DRAWINGS OR COMMENCING MANUFACTURE. THIS IS A COMPUTER GENERATED DRAWING AND SHALL NOT BE ALTERED BY HAND.

NO.	DATE	REVISION	DRAWN	CHECK
A	24.02.25	REVISED AS PER COMMENTS	U	
B	06.03.25	REVISED AS PER COMMENTS	U	



DEVELOPMENT APPLICATION

PROPOSED CAR WASH
LOT 1, No. 2 AUREA BOULEVARD
GOLDEN BAY
for SARACEN PROPERTIES

A3 SHEET
Date 01.02.25
Design U
Draw U
Checked U
Scale 1:100
Job No. 25043
Dwg. **DA04**
Rev. **B**

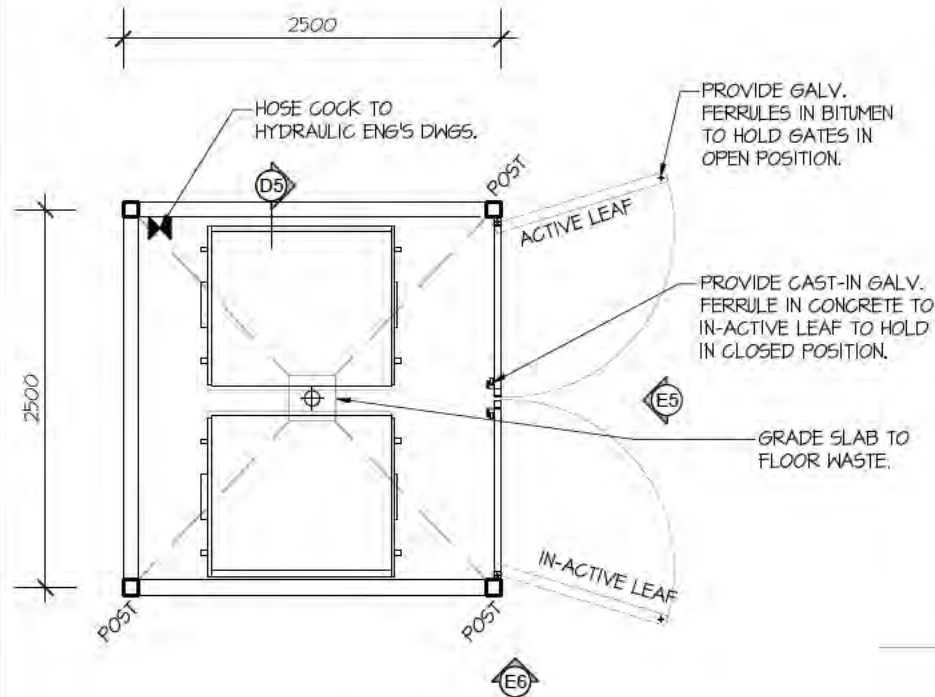

BIN STORE PLAN
SCALE - 1 : 50

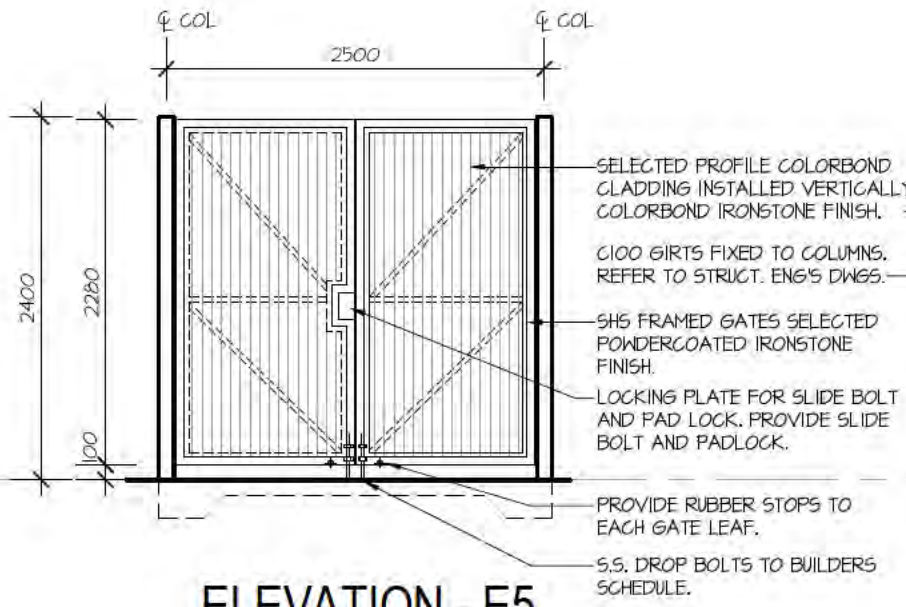

ELEVATION - E5
SCALE - 1 : 50

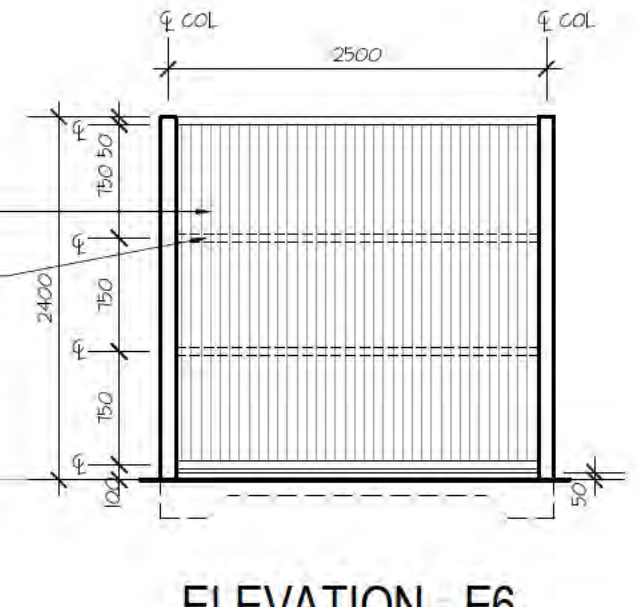

ELEVATION - E6
SCALE - 1 : 50

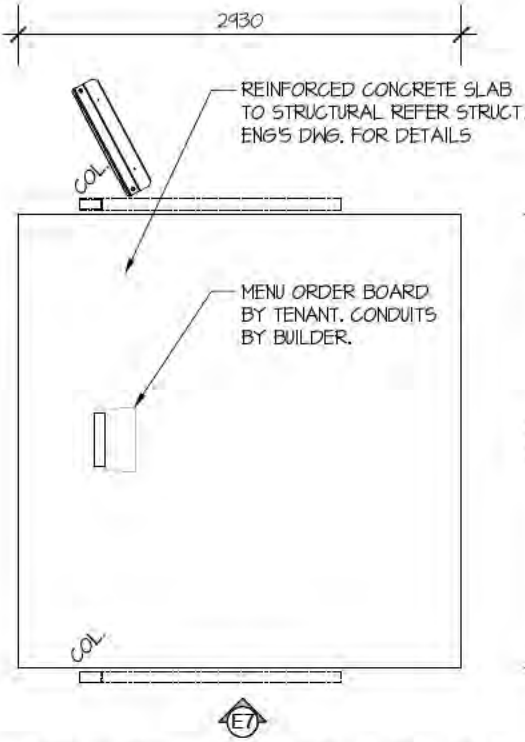

ORDER CANOPY PLAN
SCALE - 1 : 50

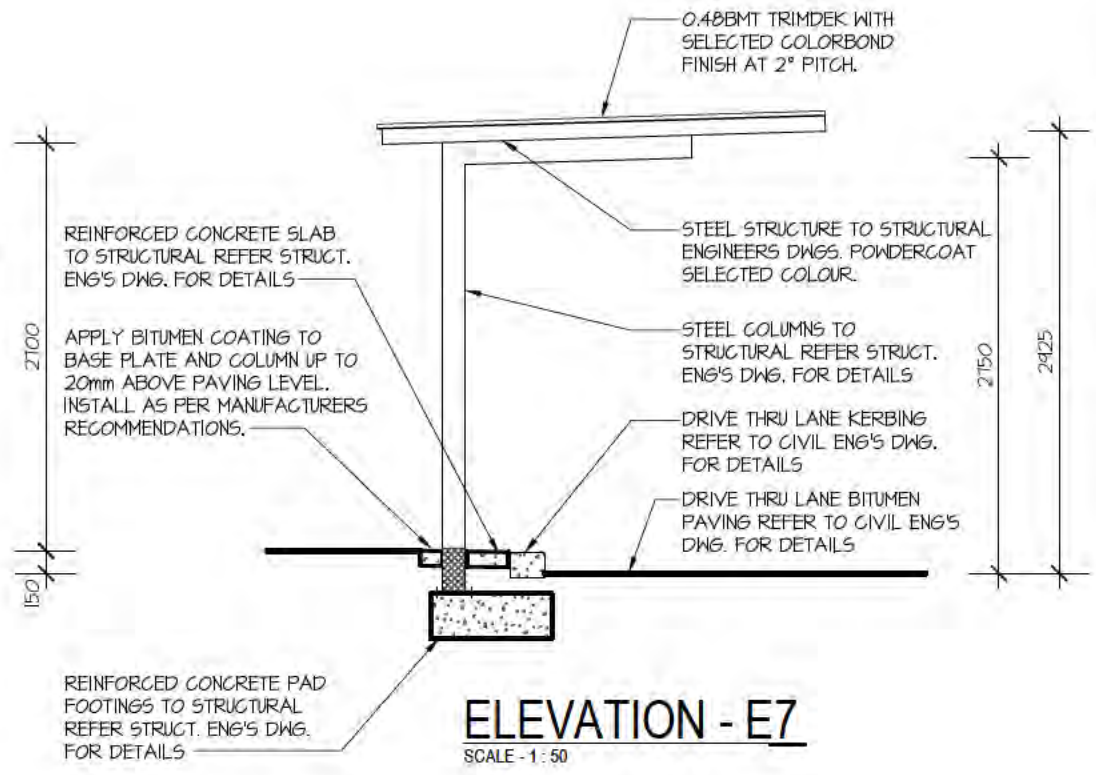

ELEVATION - E7
SCALE - 1 : 50

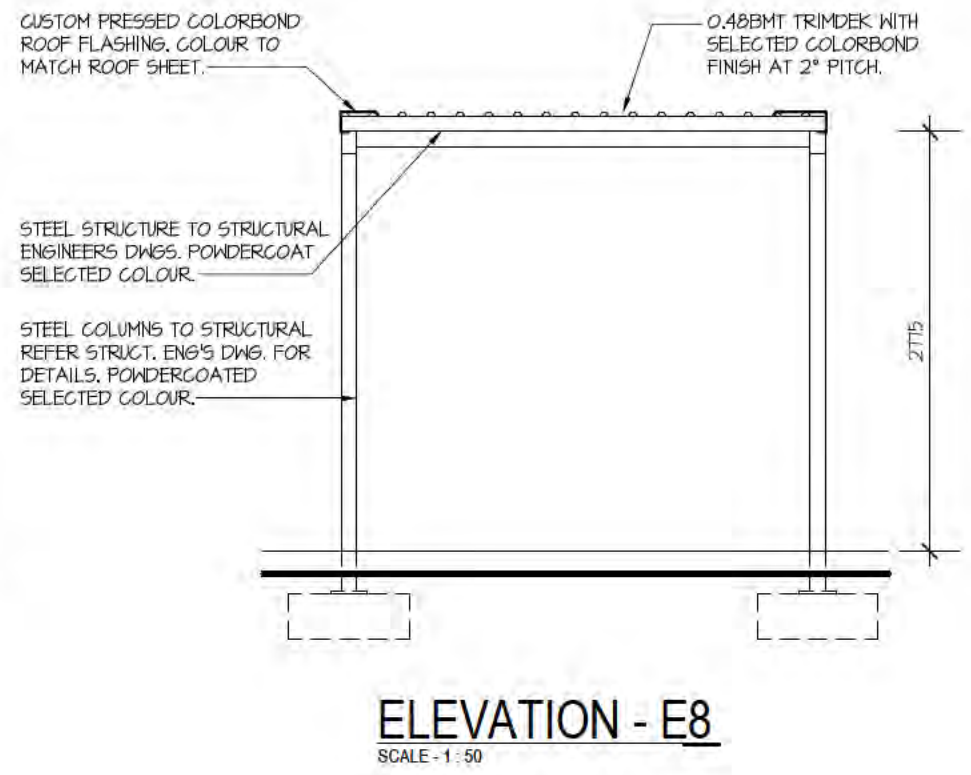

ELEVATION - E8
SCALE - 1 : 50

THIS DRAWING IS COPYRIGHT AND MUST NOT BE RETAINED, COPIED OR USED WITHOUT AUTHORITY OF HORLEY BUILDING DESIGN & DRAFTING.
DO NOT SCALE FROM THIS DRAWING.
THE CONTRACTOR AND HIS SUBCONTRACTORS ARE TO VERIFY ALL DIMENSIONS ON SITE BEFORE MAKING SHOP DRAWINGS OR COMMENCING MANUFACTURE.
THIS IS A COMPUTER GENERATED DRAWING AND SHALL NOT BE ALTERED BY HAND.

NO.	DATE	REVISION	DRAWN	CHECK



DEVELOPMENT APPLICATION
PRELIMINARY

PROPOSED CAR WASH
LOT 1, No. 2 AUREA BOULEVARD
GOLDEN BAY
for SARACEN PROPERTIES

A3 SHEET
Date: 01.02.25
Design: U
Drawn: U
Checked: U
Scale: 1:50
Job No: 55043
Dwg: **DA05**
Rev: -

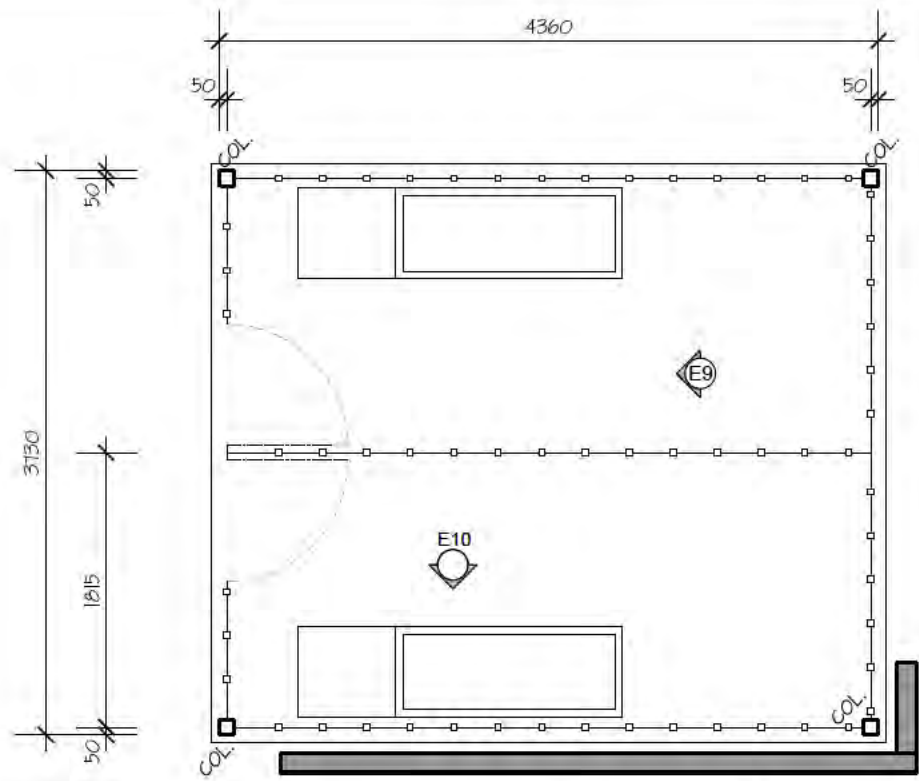

DOG WASH PLAN
SCALE - 1 : 50

1800W x 1200H ARROWS -
ACRYLIC WITH STICK ON VINYL

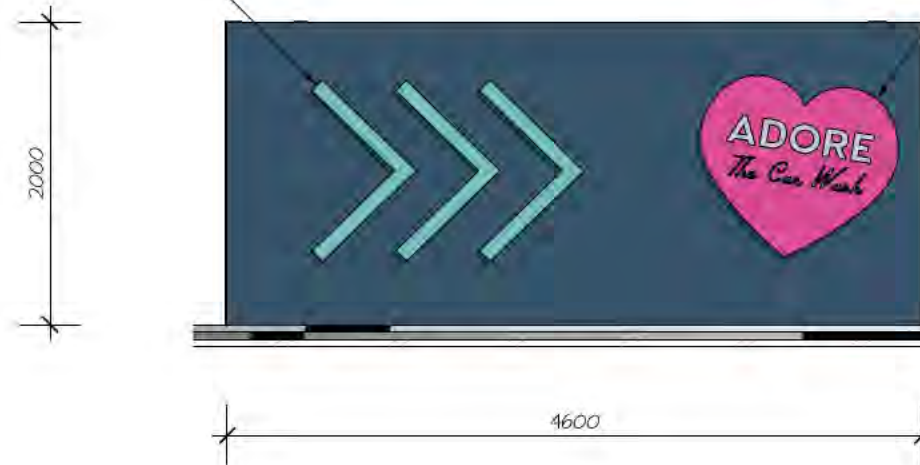

ELEVATION - E11
SCALE - 1 : 50

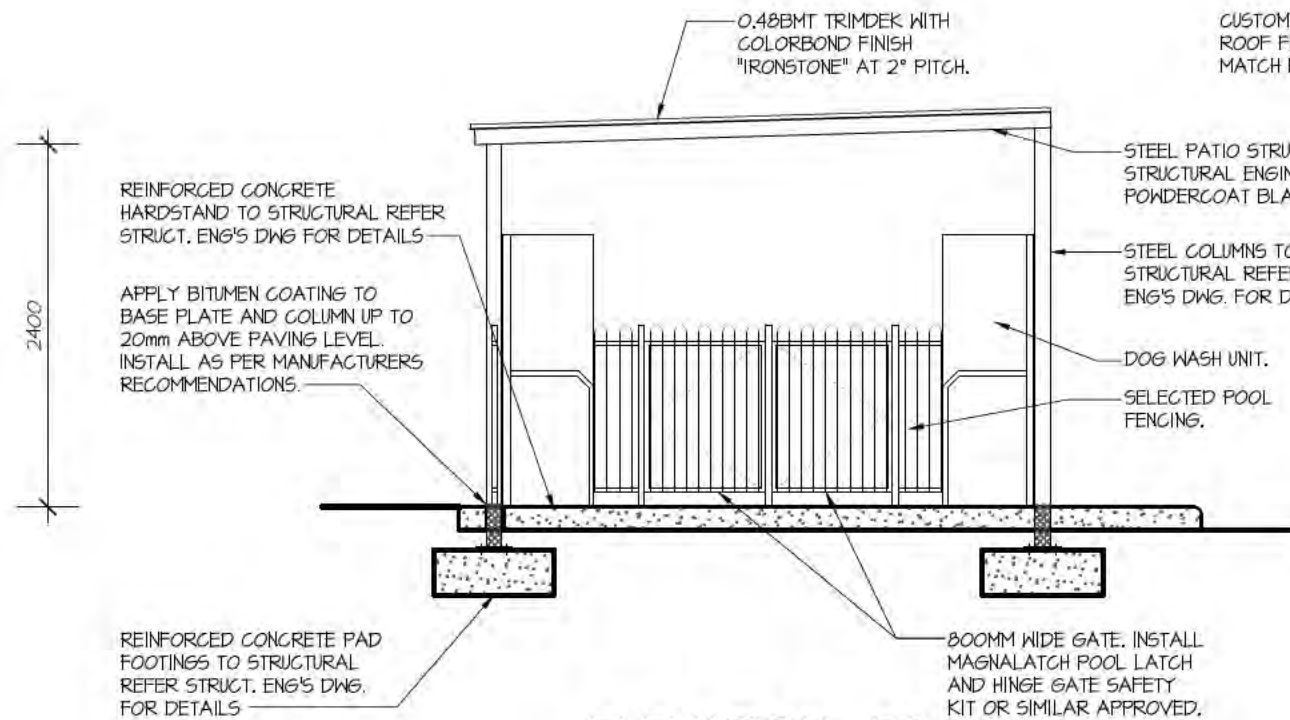

ELEVATION - E9
SCALE - 1 : 50

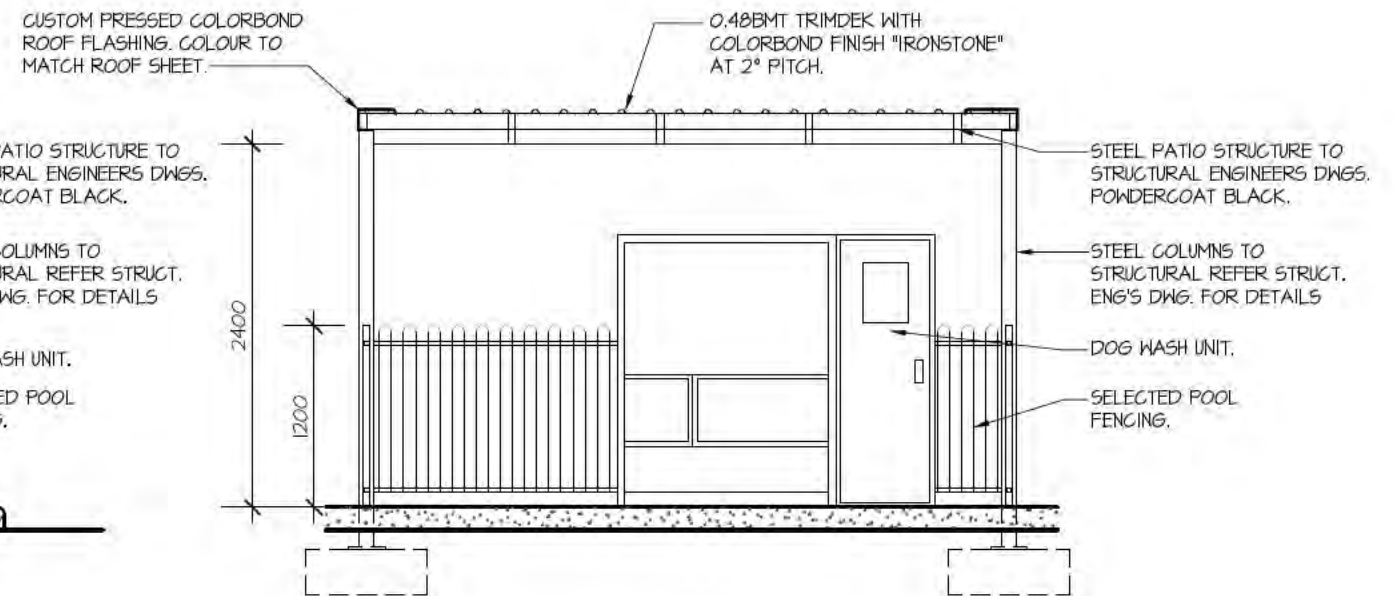

ELEVATION - E10
SCALE - 1 : 50

THIS DRAWING IS COPYRIGHT AND MUST NOT BE
REPRODUCED, COPIED OR USED WITHOUT AUTHORITY
OF HORLEY BUILDING DESIGN & DRAFTING.
DO NOT SCALE FROM THIS DRAWING.
THE CONTRACTOR AND HIS SUBCONTRACTORS ARE
TO VERIFY ALL DIMENSIONS ON SITE BEFORE MAKING
SHOP DRAWINGS OR COMMENCING MANUFACTURE.
THIS IS A COMPUTER GENERATED DRAWING AND
SHALL NOT BE ALTERED BY HAND.

NO.	DATE	REVISION	DRAWN	CHECK



DEVELOPMENT APPLICATION
PRELIMINARY

PROPOSED CAR WASH
LOT 1, No. 2 AUREA BOULEVARD
GOLDEN BAY
for SARACEN PROPERTIES

A3 SHEET
Date: 01.02.25
Design: U
Drawn: U
Checked: U
Scale: 1:50
Job No: 88043
Dwg: **DA06**
Rev: -

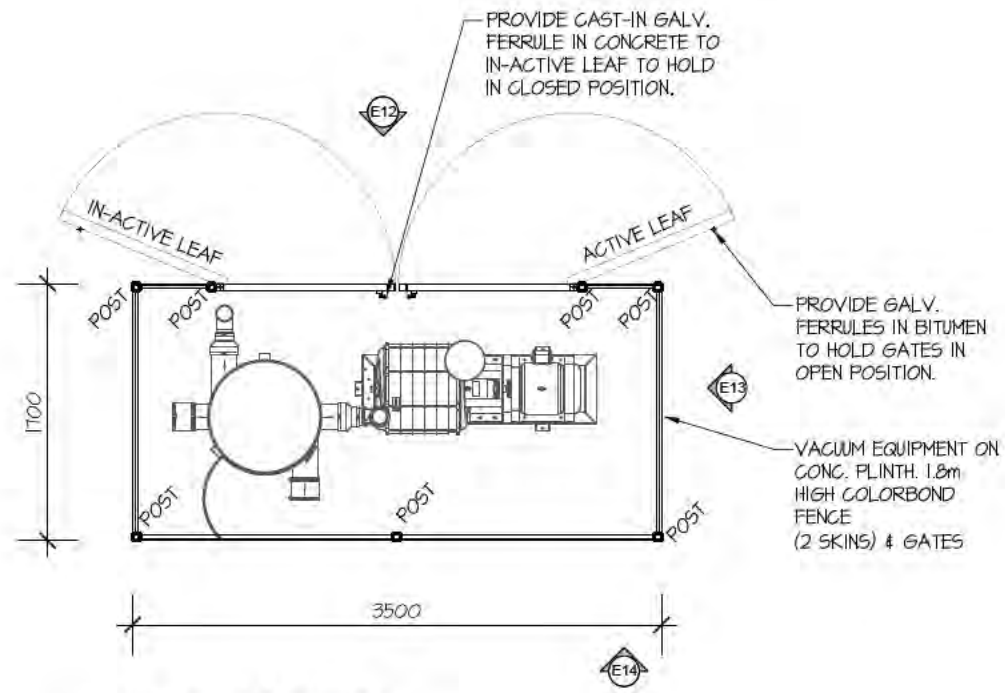

VACUUM UNIT
SCALE - 1 : 50

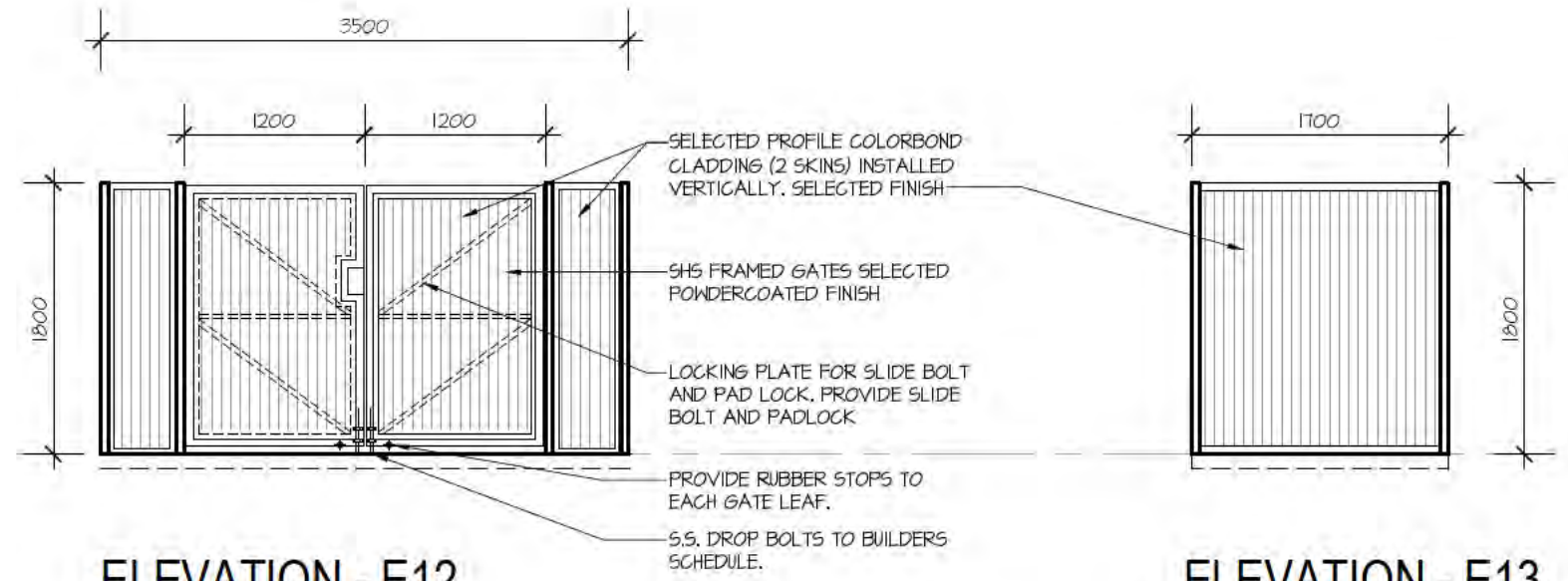

ELEVATION - E12
SCALE - 1 : 50

ELEVATION - E13
SCALE - 1 : 50

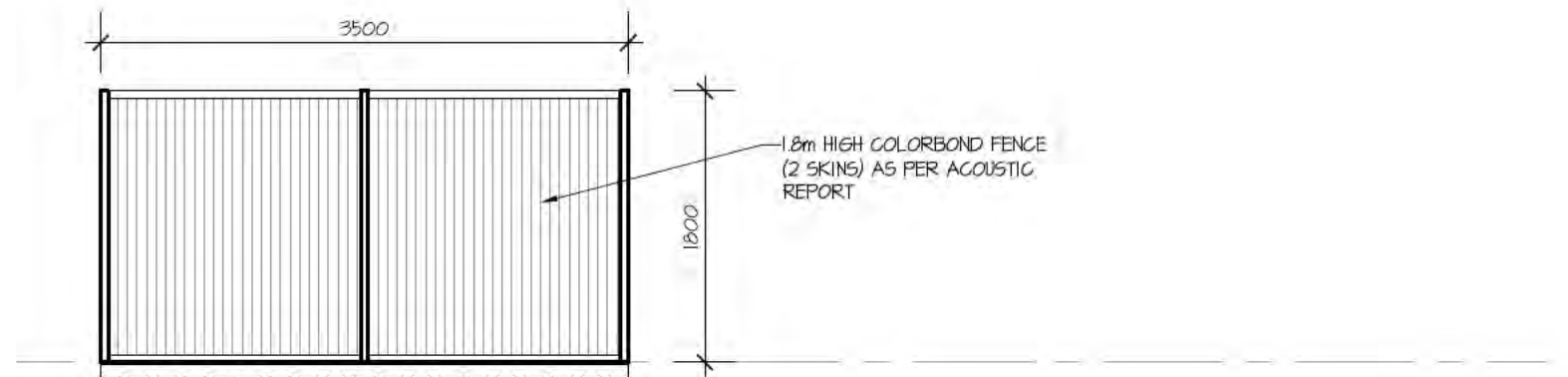

ELEVATION - E14
SCALE - 1 : 50

THIS DRAWING IS COPYRIGHTED AND MUST NOT BE RETAINED, COPIED OR USED WITHOUT AUTHORITY OF HORLEY BUILDING DESIGN & DRAFTING.
DO NOT SCALE FROM THIS DRAWING.
THE CONTRACTOR AND HIS SUBCONTRACTORS ARE TO VERIFY ALL DIMENSIONS ON SITE BEFORE MAKING SHOP DRAWINGS OR COMMENCING MANUFACTURE.
THIS IS A COMPUTER GENERATED DRAWING AND SHALL NOT BE ALTERED BY HAND.

NO.	DATE	REVISION	DRAWN	CHECK

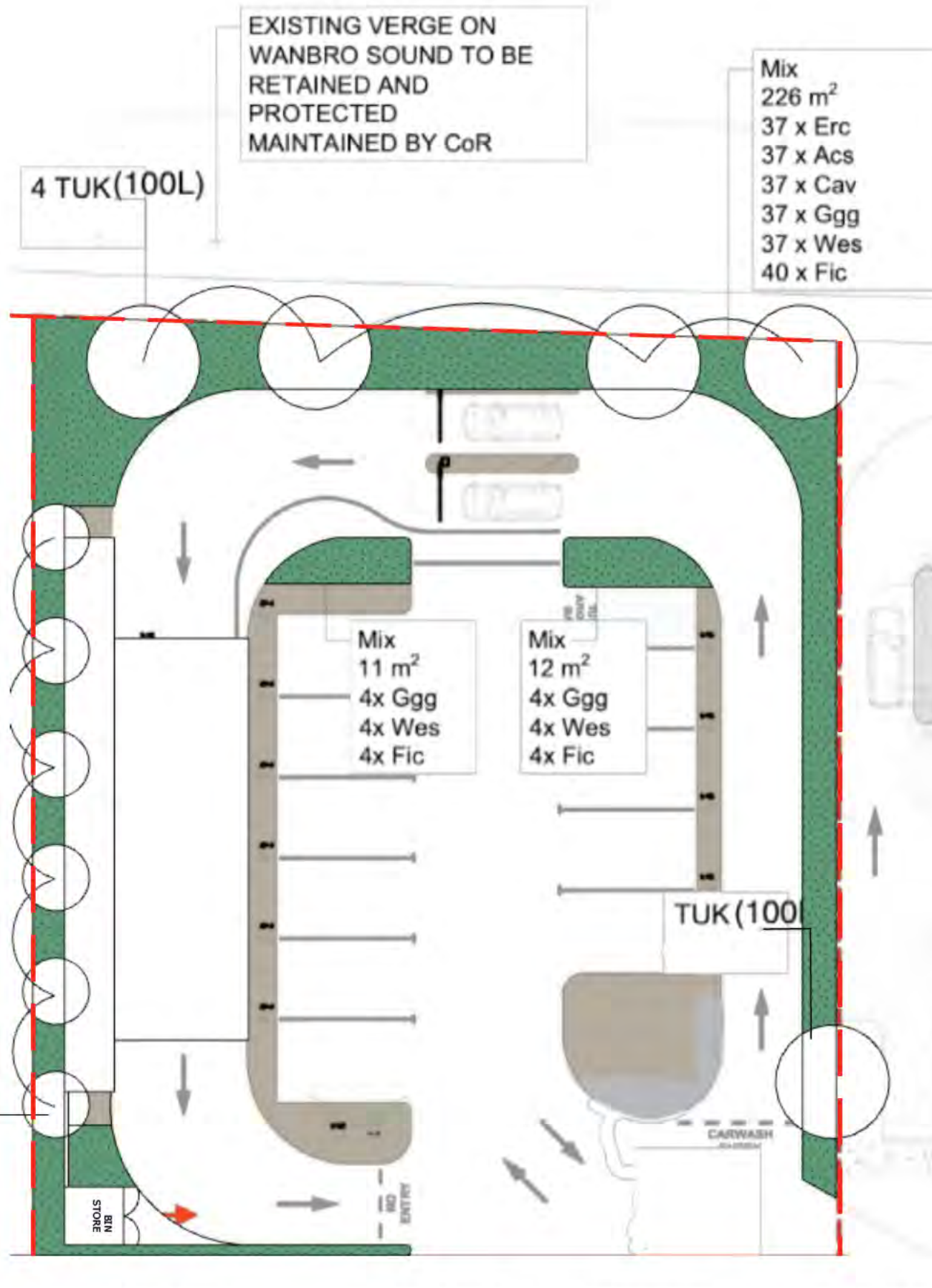

Planting Plan					
GARDEN BED	CODE	BOTANICAL NAME	DIMENSIONS W X H	POT SIZE	QUANTITY
MIX ONE (1 PER M2)	ERC	<i>Eremophila glabra</i>	2 M X 0.4M	140mm	37
	ACS	<i>Acacia saligna prostrate</i>	1M X 0.3M	140mm	37
	CAV	<i>Carpobrotus virescens</i>	1M X 0.3M	140mm	37
	GGG	<i>Grevillea gin gin gem</i>	1M X 0.3M	140mm	45
	WES	<i>Westringia grey box</i>	0.5M X 0.5M	140mm	45
	FIC	<i>Ficinia nodosa</i>	0.5M X 0.5M	140mm	48
TREES					
	HAK	<i>Hakea laurina</i>	3M X 5M	35L	6
	TUK	<i>Cupaniopsis anacardiodes</i>	6M X 10M	100L	5

--- SITE BOUNDARY

PLANTING NOTES:

1. CITY TO MAINTAIN AND MANAGE WSA VERGE DEVELOPER TO MANAGE AND MAINTAIN ALL LANDSCAPING ASSOCIATED WITH CHICKEN TREAT LANDSCAPING TO COUNCIL FOOTPATH
2. LANDSCAPED VERGE ON AUREA AVE TO BE MANAGED AND MAINTAINED BY DEVELOPER REMOVE NURSERY STAKES AND LABELS AT THE TIME OF PLANTING. PLANTS ARE TO BE SELF-SUPPORTING
3. JARRAH WOODCHIP MULCH
4. CONDITIONER (500mm) TO ALL PLANTING AREAS
5. HARDENERGIA GROW ONTO THE CHICKEN TREAT TRELLIS
6. TURF AND WOOLY BUSHES ON WANBRO SOUND AVENUE TO REMAIN
7. ALL OTHER LANDSCAPE AREAS SUBJECT TO STAGE 2

IRRIGATION NOTES:

- CONTROLLER LOCATION TO BE CONFIRMED ON SITE FOR EACH INDIVIDUAL TENANCY
- EACH TENANCY SYSTEM TO BE TO BE INDIVIDUAL MANAGED VIA INDIVIDUAL METER SYSTEM
- THE CONTRACTOR IS RESPONSIBLE FOR LAYOUT DESIGN AND INSTALLATION OF IRRIGATION SYSTEM.
- AT TIME OF COMPLETION THE IRRIGATION SYSTEM SHALL BE FULLY AUTOMATED, WORKING EFFICIENTLY AND EFFECTIVELY AND WATERING TIMES PROGRAMMED.
- LOW FLOW DRIP LINE IRRIGATION TO ALL GARDEN BEDS
- WATER SUPPLY VIA SCHEME

TYPICAL IRRIGATION SPECS:

1. MAINLINE: 25MM CLASS 9 PVC WITH 13 CORE 0.6MM MULTICORE CONTROL CABLE
2. VALVES: RAINBIRD HV WITH 1/2" RAINBIRD VALVE BOXES
3. LATERAL MANIFOLDS: 25MM LOW DENSITY POLY WITH STAINLESS STEEL COPRA CLIPS ON ALL JOINS
4. DRIP LINE: METAFIRM 1.3MM @ 30CM SPACING @ 2 LITERS PER HOUR

6 HAK (35 Lt)



REV	DATE	DESCRIPTION	REV	DATE	DESCRIPTION	PROJECT:	DRAWING:	SCALE:	1. NOT TO SCALE DRAWINGS. WRITTEN DIMENSIONS GOVERN. 2. THIS IS A CAD DRAWING. ALL DIMENSIONS ARE IN MM UNLESS NOTED OTHERWISE. 3. CONTRACTOR TO CHECK AND VERIFY ALL DIMENSIONS, LEVELS AND ANGLES ON SITE BEFORE PROCEEDING WITH THE WORK. 4. THIS DRAWING MUST BE READ IN CONJUNCTION WITH ALL RELEVANT CONTRACTS, SPECIFICATIONS AND DRAWINGS.
B	12/08/25	BIN ORIENTATION CHANGED/ HAK INCREASED TO 6				LOT 622, NO. 2 AUREA BOULEVARD, GOLDEN BAY- CAR WASH	PLANTING PLAN AND SCHEDULE	1:240 @ A3	
						CLIENT: BELLA BUILD & DESIGN	DWG NO: L-01	DATE: 12/08/25	
							DRAWN: NK	REVIEWED:	
								PROJECT NUMBER :	



OFFICIAL

Schedule of Submissions –

Proposed Amendment to Development Assessment Panel (DAP) Approval (Golden Bay Neighbourhood Centre) - Change of Use (Liquor Store to Motor Vehicle Wash) - Lot 622 (No.2) Aurea Boulevard, Golden Bay – 20.2025.175.1

PUBLIC SCHEDULE OF SUBMISSIONS						
No.	Content Manager File No.	Name	Address	Email	Support / Object/Other	Comment
1	D25/127174	Mr & Mrs Brooks	[REDACTED]	No email provided	Objection	<p>We write in response to the proposed amendment to the Development Assessment Panel (DAP) approval for Lot 622 (No.2) Aurea Boulevard, Golden Bay, seeking to change the approved land use from a 'Liquor Store' to a 'Motor Vehicle Wash'.</p> <p>As residents living in close proximity to the proposed site, we strongly object to this amendment for the following reasons:</p> <ol style="list-style-type: none"> 1. Noise Pollution: The operation of a motor vehicle wash—particularly one running from 7am to 8pm daily—will likely result in significant noise from vacuum bays, pressure washers, and vehicle movement. This would have a direct and detrimental impact on the quiet enjoyment of nearby homes, particularly for families, shift workers, and those sensitive to noise. 2 Traffic Congestion and Safety Risks: A drive-thru car wash facility with multiple vacuum bays is expected to attract a high volume of vehicles. This will increase traffic congestion in the area, particularly near residential streets such as Elvire Grove, raising safety concerns for pedestrians and children. 3. Environmental Impact: Water usage, chemical runoff, and the general environmental burden of a car wash facility within close range of homes raises concerns about the impact on local stormwater systems and nearby green spaces. 4. Incompatibility with Community Use and Vision: The original approval for a Liquor Store was consistent with a neighbourhood centre's retail and service orientation. A motor vehicle wash, however, changes the nature and character of the area from community-focused retail to an industrial-like operation, which we believe is incompatible with the intended use of the Golden Bay Neighbourhood Centre.

OFFICIAL

Schedule of Submissions –

Proposed Amendment to Development Assessment Panel (DAP) Approval (Golden Bay Neighbourhood Centre) - Change of Use (Liquor Store to Motor Vehicle Wash) - Lot 622 (No.2) Aurea Boulevard, Golden Bay – 20.2025.175.1

					<p>5. Lack of Community Consultation: Many residents, including ourselves, were unaware of this proposed change until receiving the recent notification on 6 June 2025. Given the significant deviation from the original approved land use, we believe a more thorough consultation process with the local community should be undertaken.</p> <p>For these reasons, we respectfully urge the City of Rockingham and the Metro Outer Development Assessment Panel to reject the proposed amendment and preserve the original intent and residential harmony of the Golden Bay Neighbourhood Centre.</p> <p>Thank you for the opportunity to provide input on this matter. Please acknowledge receipt of this submission.</p>
2	D25/132392	Mr David Watson-Brown	[REDACTED]	[REDACTED]	<p>Object</p> <p>My name is David Watson-Brown and owner and resident at [REDACTED]</p> <p>I am writing to voice my concerns and dismay at the Proposed Motor Vehicle Wash and the Noise which will be allowed to be introduced by this facility into a very close residential area.</p> <p>I have read the report writing by Lloyd George Acoustics and how it disregards the "Environmental Protection (Noise) Regulations 1997", in particular Regulation 7 Prescribed standard for Noise emissions subsection (2) on page 3 of the report.</p> <p>This states,</p> <p>1. "(1) Noise emitted from any premises or public place when received at other premises</p> <p>1. Must not cause or significantly contribute to, a level of noise which exceeds the assigned level in respect of noise received at premises of that kind; and</p> <p>(b) must be free of -</p> <p>1. Tonality</p>

OFFICIAL

Schedule of Submissions –

Proposed Amendment to Development Assessment Panel (DAP) Approval (Golden Bay Neighbourhood Centre) - Change of Use (Liquor Store to Motor Vehicle Wash) - Lot 622 (No.2) Aurea Boulevard, Golden Bay – 20.2025.175.1

						2. Impulsiveness 3. Modulation
--	--	--	--	--	--	-----------------------------------



LG Ref: 20.2023.35.1
DAP Ref: DAP/23/02447
Enquiries: (08) 6551 9919

State Administrative Tribunal
565 Hay Street
PERTH WA 6000

Dear Sir/Madam

**STATE ADMINISTRATIVE TRIBUNAL REVIEW OUTCOME – DR135/2023 – Apex
Planning Pty Ltd v DAP executive director**

Property Location:	Lot 622 (No.2) Aurea Boulevard, Golden Bay
Application Details:	Proposed mixed commercial development (Golden Bay Neighbourhood Centre)

Please be advised that the Metro Outer Development Assessment Panel reconsidered the above-mentioned development application, SAT ref DR135/2023, pursuant to section 31 of the *State Administrative Tribunal Act 2004* on 12 March 2024.

The Notice of Determination is attached.

Yours sincerely,

DAP executive director

20 March 2024

Encl: Amended DAP Determination Notice

Cc:
Apex Planning Pty Ltd
State Solicitor's Office
Sally Birkhead
City of Rockingham
Planning Appeals

Planning and Development Act 2005

City of Rockingham Local Planning Scheme No.2

Metro Outer Development Assessment Panel

**Determination on Development Assessment Panel
Application for Planning Approval**

Property Location: Lot 622 (No.2) Aurea Boulevard, Golden Bay

Application Details: Proposed mixed commercial development (Golden Bay Neighbourhood Centre)

Pursuant to section 31 of the *State Administrative Tribunal Act 2004*, the Metro Outer DAP, at its meeting on 12 March 2024, has reconsidered its decision dated 10 July 2023 in respect to the above application, SAT Ref. DR135/2023 and has resolved to:

1. Reconsider its decision dated 10 July 2023; and
2. **Approve** DAP Application reference DR135/2023 and accompanying revised plans and supporting information received on 22 December 2023:
 - DA001 - DA003 - Perspective
 - DA100 - Location and Survey Plan
 - DA101 - Site Plan - Rev K, Dated 16.11.2023
 - DA102 - Demolition Plan
 - DA200 - Proposed Ground Floor Plan – Rev L, Dated 16.11.2023
 - DA400 - Proposed Elevations - Streetside
 - DA401 - Proposed Elevations - Internal
 - DA900 Proposed Signage Schedule
 - DA901 - DA902 - Material Schedule
 - DA905 - Pedestrian Movement Diagram
 - Landscape Concept Plan
 - Landscape Piazza Concept Plan
 - Development Application Report
 - Traffic Impact Assessment (May 2023), including Technical Note No.1 (Dated 30.11.2023)
 - Environmental Noise Assessment (Acoustic Report) (Dated 28.4.2023)
 - Emissions Impact Assessment (EIA) (Dated December 2023)

in accordance with Clause 68 of the Planning and Development (Local Planning Schemes) Regulations 2015 and the Metropolitan Region Scheme, subject to the following conditions:

1. This decision constitutes planning approval only, and is valid for a period of 4 years from the date of approval. If the subject development is not substantially commenced within the specified period, the approval shall lapse and be of no further effect.
2. Prior to applying for a Building Permit, a Construction Management Plan (CMP) is to be submitted to and approved by the City of Rockingham addressing but not limited to:
 - (i) Hours of construction;
 - (ii) Temporary fencing;
 - (iii) Traffic management including a Traffic Management Plan addressing site access, egress and parking arrangement for staff and contractors;
 - (iv) Management of vibration and dust; and
 - (v) Management of construction noise and other site generated noise.
3. Prior to applying for a Building Permit, a Stormwater Management Plan must be prepared by a suitably qualified engineering consultant showing how stormwater will be contained on-site, including with specific provision for the Service Station. Those plans must be submitted to the City of Rockingham for approval. All stormwater generated by the development must be managed in accordance with Planning Policy 3.4.3 - Urban Water Management to the satisfaction of the City of Rockingham. The approved plans must be implemented and all works must be maintained for the duration of the development.
4. Prior to applying for a Building Permit, the Proponent must submit fully detailed civil engineering drawings showing the various footpaths, crossovers and car parking embayments to be adopted across the entire development site and adjoining road reserves, for review and approval by the City of Rockingham. Construction works in accordance with approved civil drawings are to be completed prior to occupation of the development, at the landowner's cost to the satisfaction of the City of Rockingham.
5. Prior to applying for a Building Permit, a Landscaping Plan must be prepared and include the following detail to the satisfaction of the City of Rockingham:
 - (i) The location, number and type of existing and proposed trees and shrubs (including street trees, shade trees within the car parking areas, and planting within verge areas), including calculations for the landscaping area;
 - (ii) Any lawns to be established and areas to be mulched;
 - (iii) Those areas to be reticulated or irrigated;
 - (iv) Proposed upgrading to landscaping, paving and reticulation of the street setback area and all verge areas;
 - (v) Protection and enhancement of existing vegetation within the verge areas of Warnbro Sound Avenue and Aurea Boulevard;

- (vi) Detailed landscape, irrigation, lighting and street furniture plans; and
- (vii) The paving material used for the footpaths shall be carried across all crossovers in order to maintain the visual continuity of the pedestrian network and aid pedestrian legibility.

The landscaping, paving and reticulation must be completed prior to the occupation of the development, and must be maintained at all times to the satisfaction of the City of Rockingham for the duration of the development.

6. Prior to occupation of the development, car parking areas must:
 - (i) Provide a minimum of 147 car parking spaces, including 4 parking spaces within the Thundelarra Drive road reserve adjoining the development;
 - (ii) Be designed, constructed, sealed, kerbed, drained and marked in accordance with User Class 3A of Australian/New Zealand Standard AS/NZS 2890.1:2004, Parking facilities, Part 1: Off-street car parking;
 - (iii) Provide seven (7) car parking space(s) dedicated to people with disabilities, which are designed, constructed, sealed, kerbed, drained and marked in accordance with Australian/New Zealand Standard AS/NZS 2890.6:2009, Parking facilities, Part 6: Off-street parking for people with disabilities and which are linked to the main entrance of the development by a continuous accessible path of travel designed and constructed in accordance with Australian Standard AS 1428.1—2009, Design for access and mobility, Part 1: General Requirements for access—New building work;
 - (iv) Be constructed, sealed, kerbed, drained and marked prior to the development being occupied and maintained thereafter; and
 - (v) Comply with the above requirements for the duration of the development.
7. The Environmental Noise Assessment prepared by Lloyd George Acoustics dated 28 April 2023 (ref: 22117749-01A), shall be implemented in the design, construction and ongoing operation of the development at all times to the satisfaction of the City of Rockingham, including but not limited to the following requirements:
 - (i) The Supermarket loading bay to be screened as follows:
 - (a) A 3.0m acoustic screen wall to be constructed on the northern side of the Supermarket loading bay, and extended the length of the loading bay, of solid construction (no gaps) and of material with a minimum surface mass of 15kg/m².
 - (b) The design and finish of the screen wall to be designed, coloured and articulated to provide an attractive appearance to Wyloo Lane, to the satisfaction of the City of Rockingham.

- (c) The loading bay overhead (roof) structure to extend at least 4m across the loading bay and be lined with an absorptive material such as anticon insulation. No gaps shall exist between the overhead section and the vertical acoustic screenwall.
 - (ii) A solid screen wall to be constructed in the vicinity of the Liquor Store bin area fronting Warnbro Sound Avenue, of minimum height 1.6m and of minimum surface mass of 4kg/m², and be free of gaps, as shown on the approved plans. The screening to be of a masonry construction and of a suitable design complementing the overall development, as illustrated in the Material Schedule, to ensure an attractive appearance to Warnbro Sound Avenue and internal to the site to the satisfaction of the City of Rockingham, having regard to the high level of visibility of the screen wall to Warnbro Sound Avenue.
 - (iv) Acoustic screening around the northern and western edges of the Supermarket to air conditioning and refrigeration equipment in order to protect existing and future residential development from noise, in accordance with the *Environmental Protection (Noise) Regulations 1997*.
 - (v) Use of broadband type reversing alarms for delivery vehicles rather than standard tonal alerts.
 - (vi) Delivery vehicles are not allowed to idle within the loading bays, and are required to be switched off during loading and unloading periods.
 - (vii) Bin servicing via Wyloo Lane shall occur only between 7am and 6pm Mondays to Fridays and 9am to 5pm on Saturdays; and 7am to 7pm Mondays to Saturdays otherwise. No bin servicing shall occur on a Sunday.
 - (viii) Any external music or the like shall be low level and inaudible at residences.
 - (ix) Section 5 recommendations in the Environmental Noise Assessment for mechanical plant shall be implemented.
8. Deliveries via Wyloo Lane shall only occur between 6am to 6pm Monday to Friday, and 9am to 5pm on Saturdays. No deliveries are permitted on Sundays. Signage shall be positioned at the entry to the site from Wyloo Lane specifying delivery times, to minimise adverse impacts on the amenity of the adjacent residence(s).
9. Prior to the occupation of the development, a Final Acoustic Assessment must be prepared and provided to the City of Rockingham which demonstrates to City's satisfaction, that the completed development complies with the *Environmental Protection (Noise) Regulations 1997*.

The Final Acoustic Assessment must include the following information:

- (i) Noise sources compared with the assigned noise levels as stated in the *Environmental Protection (Noise) Regulations 1997*, when the noise is received at the nearest "noise sensitive premises" and surrounding residential area;

- (ii) Tonality, modulation and impulsiveness of noise sources; and
- (iii) Confirmation of the implementation of noise attenuation measures.

Any further works must be carried out in accordance with the Acoustic Report and implemented as such for the duration of the development.

10. Prior to applying for a Building Permit, a City Approved Waste Management Plan must be prepared and include the following detail:
 - (i) For the Supermarket and specialty shops, include waste generation quantities, number, volume and type of bins, proposed collection frequency and cleaning and maintenance of the bin store. With at least one food business likely within the specialty shops, any liquid waste storage (eg. used oil) to also be addressed;
 - (ii) For all premises within the development:
 - (a) the location of bin storage areas and bin collection areas;
 - (b) the number, volume and type of bins, and the type of waste to be placed in the bins;
 - (c) management of the bins and the bin storage areas, including cleaning, rotation and moving bins to and from the bin collection areas;
 - (d) frequency of bin collections;
 - (e) regular rubbish collection patrols; and
 - (f) demonstration of compliance with the Acoustic Report prepared by Lloyd George Acoustics.

All works must be carried out in accordance with the Waste Management Plan and maintained at all times, for the duration of development.

11. Prior to occupation of the development, public rubbish bin facilities must be provided adjacent to the entry of the Supermarket premises so as to be convenient to pedestrians, but positioned so as not to obstruct pedestrian movements, to the satisfaction of the City of Rockingham.
12. Prior to the occupation of the development, any damage to existing City infrastructure within the road reservation including kerb, road pavement, turf, irrigation, bollards and footpaths is to be repaired to the satisfaction of the City of Rockingham, at the cost of the Applicant.
13. A pedestrian refuge being installed within the Thundelarra Drive and Aurea Boulevard crossovers to assist pedestrian safety given the extended width required for this crossover to service the development.
14. Prior to the occupation of the development, an illumination report must be prepared which demonstrates to the satisfaction of the City of Rockingham, that the completed development complies with the requirements of Australian Standard AS/NZS 4282:2019 - *Control of the obtrusive effects of outdoor lighting*, and manages light spill to existing and future adjoining/nearby residential lots to the north, west and north-west of the site.

15. Prior to occupation of the development, fifteen (15) short-term bicycle parking spaces must be provided for the development. The bicycle parking spaces must be designed in accordance with AS2890.3—1993, *Parking facilities, Part 3: Bicycle parking facilities* and located within the development to the satisfaction of the City of Rockingham.
16. Prior to the occupation of the development, in accordance with Planning Policy 3.3.25 Percent for Public Art – Private Developer Contribution, the developer shall make a contribution to the City of Rockingham equal to 1% of the total construction value for the provision of public art, being \$110,000.
17. Earthworks over the site associated with the development must be stabilised to prevent sand or dust blowing off the site, and appropriate measures must be implemented within the time and in the manner directed by the City of Rockingham in the event that sand or dust is blown from the site.
18. Bulk fuel deliveries to be limited to 7am - 7pm Monday to Saturday.
19. All plant and roof equipment and other external fixtures must be designed to be located away from public view/or screened for the life of the development, to the satisfaction of the City of Rockingham.
20. The mall area located between the Supermarket and specialty shops shall be maintained in a clean, tidy and sanitary condition with routine high pressure water cleaning to prevent any accumulations of litter, grime or oily deposits, to the satisfaction of the City of Rockingham.
21. Prior to applying for a Building Permit, the applicant must demonstrate to the satisfaction of the City of Rockingham that ground floor glazing of the Supermarket fronting Thundelarra Drive, along with the Specialty Shops facing Thundelarra Drive and all windows facing the mall, have a minimum visible light transmission rate of at least 79% and a maximum visible reflectivity rate of 9% in order to ensure that a commercial, interactive frontage is available to the development from Thundelarra Drive and the mall. The glazing must be thereafter installed and maintained to the satisfaction of the City of Rockingham for the duration of the development.
22. Entries and window frontages of the Supermarket and specialty shop tenancies facing Thundelarra Drive and the mall must contain clear, transparent glass, and not be covered, closed or screened off (including by means of dark or other tinting, shutters, curtains, blinds, posters, paint, roller doors or similar), to ensure that visibility and a commercial, interactive frontage is available between the development and Thundelarra Drive at all times.
23. The internal layout of the Supermarket shall ensure Supermarket aisles do not extend to the windows fronting Thundelarra Drive, and shelving and storage be located to ensure no obstruction of windows occurs, in order to maintain the view between Thundelarra Drive and the Supermarket tenancy.
24. Trolley storage shall occur within the Supermarket tenancy or within designated trolley parking bays within the carparking area, and not within the mall or along the Thundelarra Drive frontage.

25. The awning in front of the specialty shops on Thundelarra Drive shall be extended south by 3.5m to provide weather protection for the bike parking area.
26. Bollards must be installed at both ends of the mall to ensure no vehicle access along the mall. All other parking bays to contain wheel stops to prevent vegetation damage, and prevent encroachment to the pedestrian movement network.
27. The proposed Service Station must incorporate Stage 1 and Stage 2 (VR1 and VR2) Vapour Recovery Systems which are to be installed and operated from the commencement of operation of the Service Station, and for the duration of its operation. These systems are to be operated at all times, and under a regular program of inspection and maintenance for the life of the development.
28. The existing, redundant steel frame and slab on site being removed prior to commencement of development.
29. An Odour Management Plan for the Fast Food Outlets shall be prepared for the approval of the City's Environmental Health Services prior to issue of a Building Permit, demonstrating management of odour impact on surrounding existing and future residential properties.
30. Prior to applying for a Building Permit, a Sign Strategy must be prepared which must include the information required by Planning Policy 3.3.1: Control of Advertisements, to the satisfaction of the City of Rockingham, and it must thereafter be implemented for the duration of the development.
31. An Operational Management Plan being prepared for the Service Station for the approval of the City prior to the issue of a Building Permit, demonstrating required vehicle movement through bowsters, and contingency in the instance the VR2 system fails to operate.
32. During the operating hours of the Fast Food Outlets, all rubbish associated with the Fast Food Outlets must be collected daily from the associated carparking areas to the satisfaction of the City.

Advice Notes

1. The disposal of wastewater into the Water Corporation's sewerage system must be with the approval of the Water Corporation; the applicant and owner should liaise with the Water Corporation in this regard.
2. The development must comply with the *Food Act 2008*, the *Food Safety Standards* and Chapter 3 of the *Australian New Zealand Food Standards Code (Australia Only)*; the applicant and owner should liaise with the City's Health Services in this regard.
3. A Building Permit must be obtained for the proposed works prior to commencement of site works. The applicant and owner should liaise with the City's Building Services in this regard.
4. The development must comply with the *Environmental Protection (Noise) Regulations 1997*; contact the City's Health Services for information on confirming requirements.

5. All works in the road reserve, including construction of a crossover, planting of street trees, and other streetscape works and works to the road carriageway must be to the specifications of the City of Rockingham; the applicant should liaise with the City of Rockingham's Engineering Services in this regard.
6. In regards to Condition 2(iv), Dust Management is to be in accordance with the *Department of Environment and Conservation Guideline: A guideline for managing the impacts of dust and associated contaminants from land development sites, contaminated sites remediation and other related activities*.
7. The Liquor Store is to comply with the Liquor Control Act 1988, all relevant approvals and licenses are to be sought prior to the occupation of the development in conjunction with the Department of Local Government, Sport and Cultural Industries.
8. A site cannot store or sell fuel without first obtaining a licence from the Department of Mines Industry Regulation and Safety, which requires strict criteria to be met and assessed as part of the process regulated under the *Dangerous Goods Safety Act 2005*.
9. A separate Development Approval may be required for the occupation of any tenancy not specified in this approval, prior to the occupation of the tenancy. The City's Planning Services should be contacted to determine whether development approval is required.
10. Where a Development Approval has so lapsed, no development shall be carried out without further approval having first been sought and obtained, unless the Applicant has applied and obtained Development Assessment Panel approval to extend the approval term under regulation 17(1)(a) of the *Planning and Development (Development Assessment Panels) Regulations 2011*.

Where an approval has so lapsed, no development shall be carried out without further approval having first been sought and obtained, unless the applicant has applied and obtained Development Assessment Panel approval to extend the approval term under regulation 17(1)(a) or local government approval under regulation 17A of the *Planning and Development (Development Assessment Panels) Regulations 2011*.

DEVELOPMENT
ASSESSMENT PANEL

APPROVED

12-Mar-2024



IMAGES ARE INDICATIVE ONLY

2 - AERIAL VIEW OF PROPOSED DEVELOPMENT

DEVELOPMENT
ASSESSMENT PANEL

APPROVED

12-Mar-2024

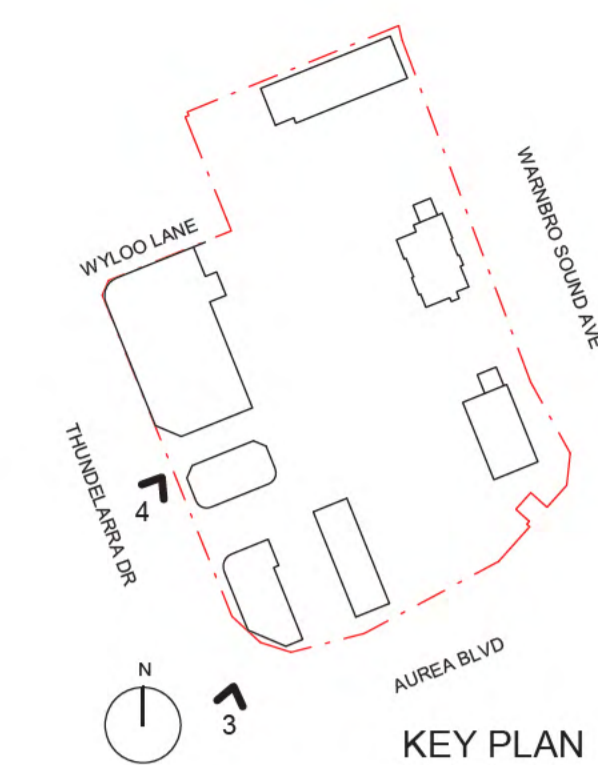

3 - VIEW OF CORNER OF THUNDELARRA DRIVE AND AUREA BOULEVARD



4 - VIEW OF ARCADE

DEVELOPMENT
ASSESSMENT PANEL

APPROVED

12-Mar-2024



IMAGES ARE INDICATIVE ONLY

5 - VIEW OF LIQUOR STORE AND ENTRY TO DRIVE THROUGH

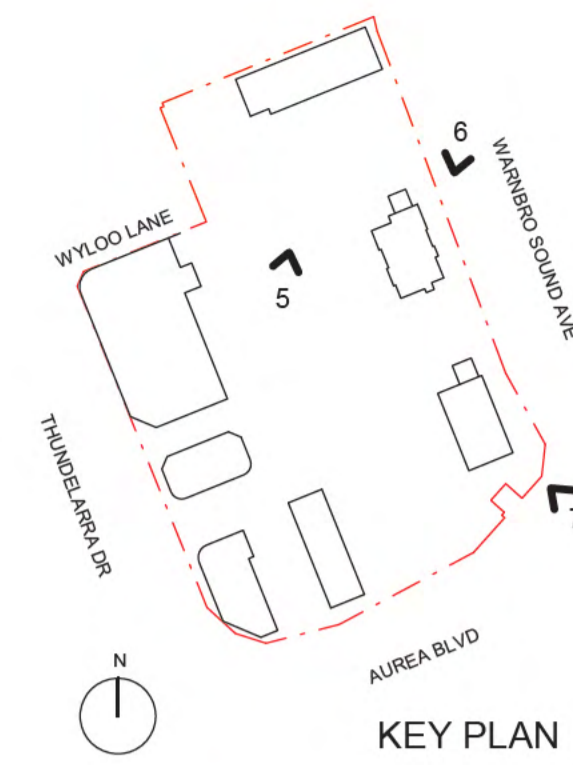

KEY PLAN



IMAGES ARE INDICATIVE ONLY

6 - VIEW OF SCREENING TO DRIVE THROUGH



IMAGES ARE INDICATIVE ONLY

7 - VIEW OF CORNER OF WARNBRO SOUND AVENUE AND AUREA BOULEVARD

**DEVELOPMENT
ASSESSMENT PANEL**

APPROVED

12-Mar-2024

LEGEND	
▲	TBM
+	NAT SURFACE PT
□	COMMS PIT
○	WATER STOP
⊕	HYDRANT GROUND
⊕	WATER METER
⊕	WATER RISER
⊕	RETIC CONTROL VALVE
⊕	POWER DOME
⊕	LAMP POST
⊕	CABLE PIT
⊕	EARTH ROD
⊕	DISTRIBUTION BOARD
⊕	SIDE ENTRY PIT
⊕	DRAINAGE GRATE (ROUND)
⊕	SEWER MANHOLE
⊕	UNKNOWN PIT
⊕	PVC RISER
⊕	COLUMNS
▽	GIVE WAY
⊕	SIGN - SINGLE POLE
⊕	UNKNOWN BOX
⊕	TRAFFIC LIGHT
*	PAD LEVEL

LINE TYPES	
---	ROAD CENTRELINE
---	BOTTOM OF KERB
---	TOP OF KERB
---	EDGE OF BITUMEN
---	EDGE OF CONCRETE
---	BRICK PAVING
---	FOOTPATH
---	STOCKPILES
---	FENCE
---	COLUMNS
---	BOUNDARY
---	SEWER LINE
---	POWER TRANSFORMER
---	UNKNOWN MANHOLE



1 LOCATION PLAN
1:2000



2 SITE SURVEY
1:400



OVERALL AREA (GLAR)	
TENANCY	AREA
FAST FOOD	525 m ²
LIQUOR	230 m ²
SERVICE STATION	305 m ²
SPECIALTY	265 m ²
SUPERMARKET	1165 m ²
TOTAL GLAR	2490 m²

CAR PARKING PROVIDED - OVERALL	
TYPE	COUNT
STANDARD CAR BAY	96
QUEUEING BAY	40
ON-STREET PARKING	4
BICYCLE RACKS	15
ACROD BAYS	7
TOTAL BAYS	162

**DEVELOPMENT
ASSESSMENT PANEL**

APPROVED

12-Mar-2024



VIEW OF EXISTING STRUCTURE ALONG THUNDELARRA DRIVE



1 PROPOSED DEMOLITION PLAN
1:400

DEVELOPMENT ASSESSMENT PANEL

APPROVED

12-Mar-2024

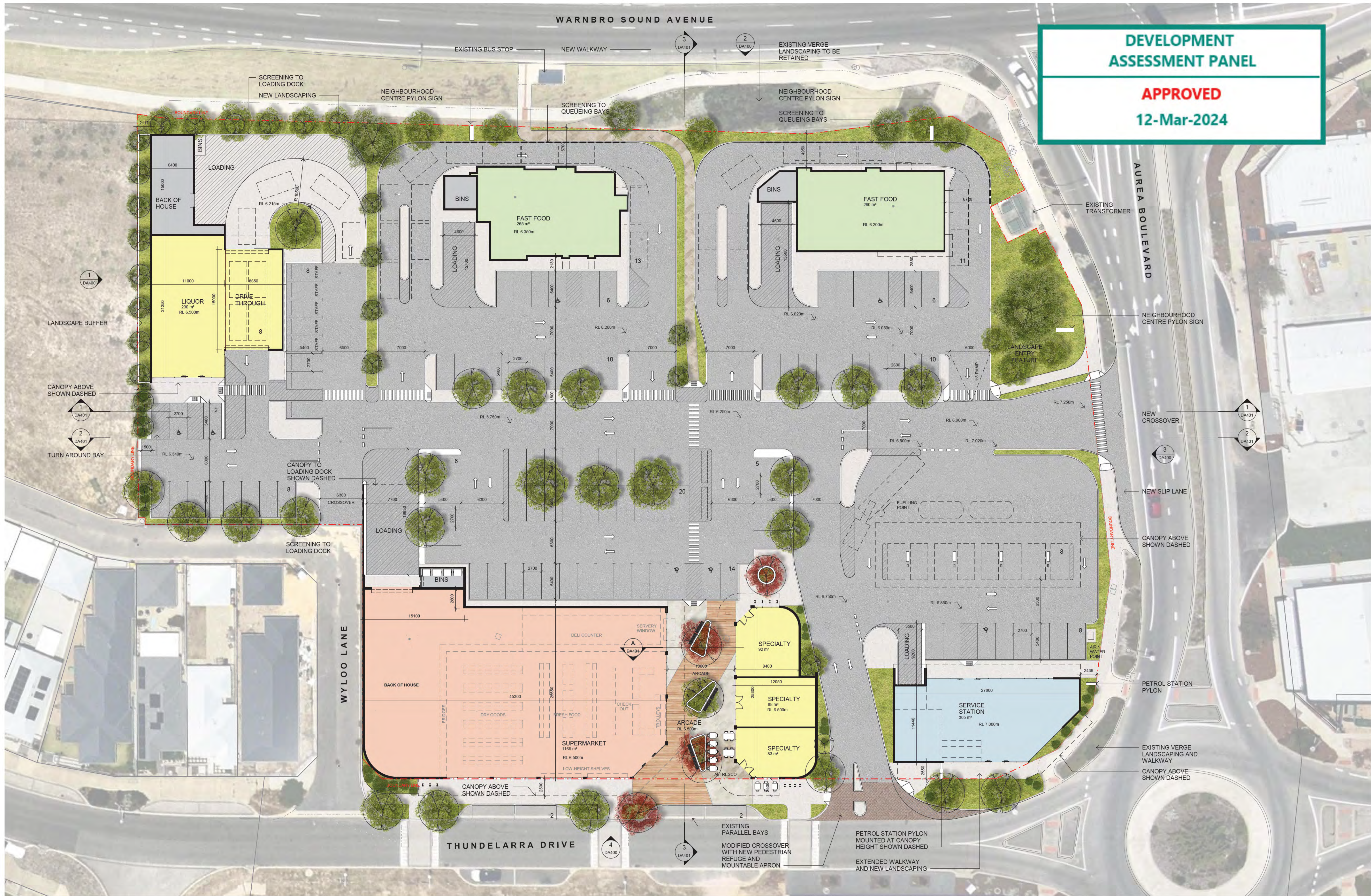

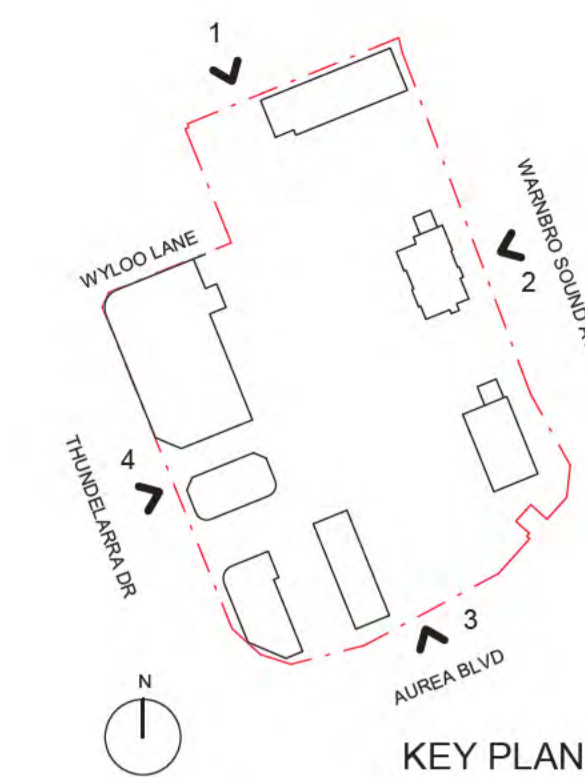
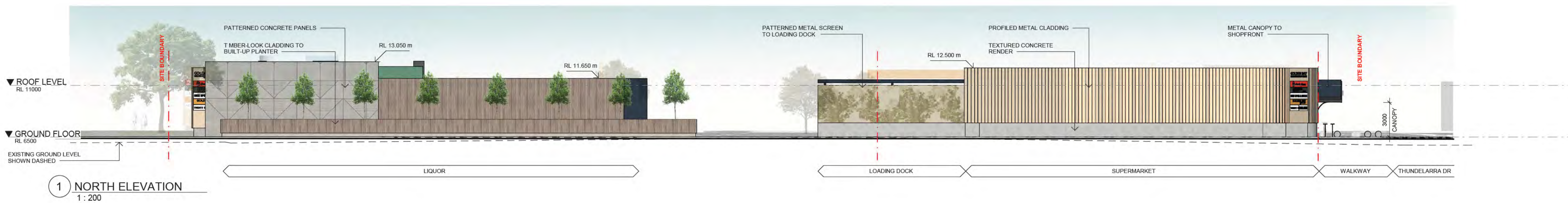

DEVELOPMENT ASSESSMENT PANEL

APPROVED

12-Mar-2024

NOTE: ALL TENANT SIGNS SHOWN ARE INDICATIVE ONLY

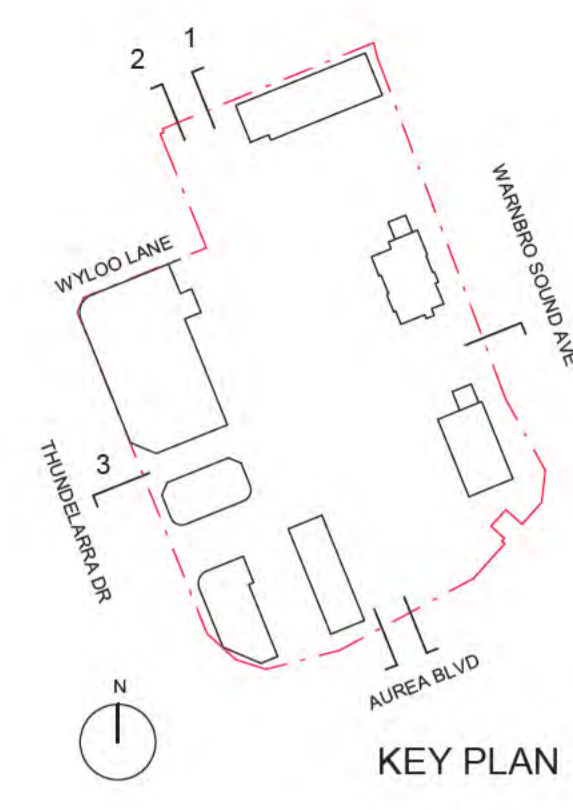
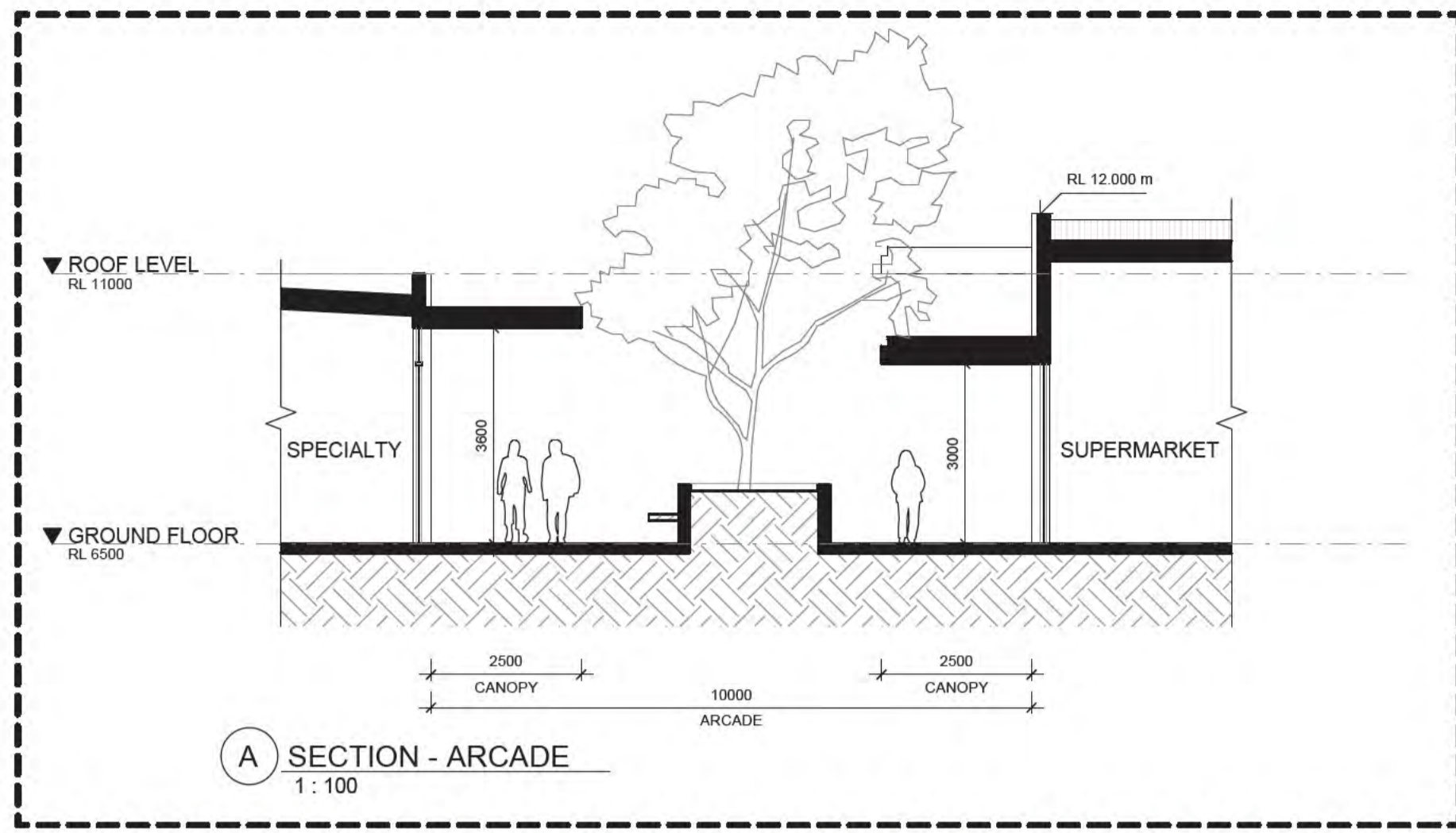

**DEVELOPMENT
ASSESSMENT PANEL**

APPROVED

12-Mar-2024

NOTE: ALL TENANT SIGNS SHOWN ARE INDICATIVE ONLY



PROPOSED ELEVATIONS - INTERNAL
GOLDEN BAY NEIGHBOURHOOD CENTRE

Status: **DEVELOPMENT APPLICATION**
Path: C:\Users\I.azhar\Documents\Revit Local Files\2020\44634 - Golden Bay Neighbourhood Centre_L.Azhar.rvt

Scale: 1:200 @ A1
0 16
© Hames Sharley:

Project Number: 44634
Drawing Number: DA401
Revision: E
Date: 28.04.23



SIGN NO	INDICATIVE IMAGE	DESCRIPTION	INDICATIVE SIZE
SGN001		FREE-STANDING NEIGHBOURHOOD CENTRE PYLON SIGNAGE	2400mm W x 6000mm H
SGN002		WALL-MOUNTED NEIGHBOURHOOD CENTRE PYLON SIGNAGE	2400mm W x 4800mm H
SGN003		WALL-MOUNTED TENANT SIGNAGE	6000mm W x 1600mm H
SGN004		WALL-MOUNTED TENANT BLADE SIGNAGE	700mm W x 500mm H
SGN005		TENANT SHOPFRONT SIGNAGE	3000mm W x 500mm H
SGN006		FREE-STANDING SERVICE STATION PYLON SIGNAGE WITH DIGITAL PRICE BOARD	1800mm W x 6000mm H
SGN007		CANOPY-MOUNTED SERVICE STATION PYLON SIGNAGE WITH DIGITAL PRICE BOARD	1800mm W x 3000mm H
SGN008		SERVICE STATION SHOPFRONT SIGNAGE	7200mm W x 2000mm H
SGN009		SERVICE STATION CANOPY SIGNAGE	3000mm W x 1000mm H
SGN010		SUSPENDED TENANT SIGNAGE	6000mm W x 1000mm H
SGN011		WALL-MOUNTED TENANT DRIVE-THROUGH SIGNAGE	6000mm W x 500mm H
SGN012		WALL-MOUNTED TENANT LOADING SIGNAGE	4000mm W x 750mm H

DEVELOPMENT ASSESSMENT PANEL

APPROVED

12-Mar-2024

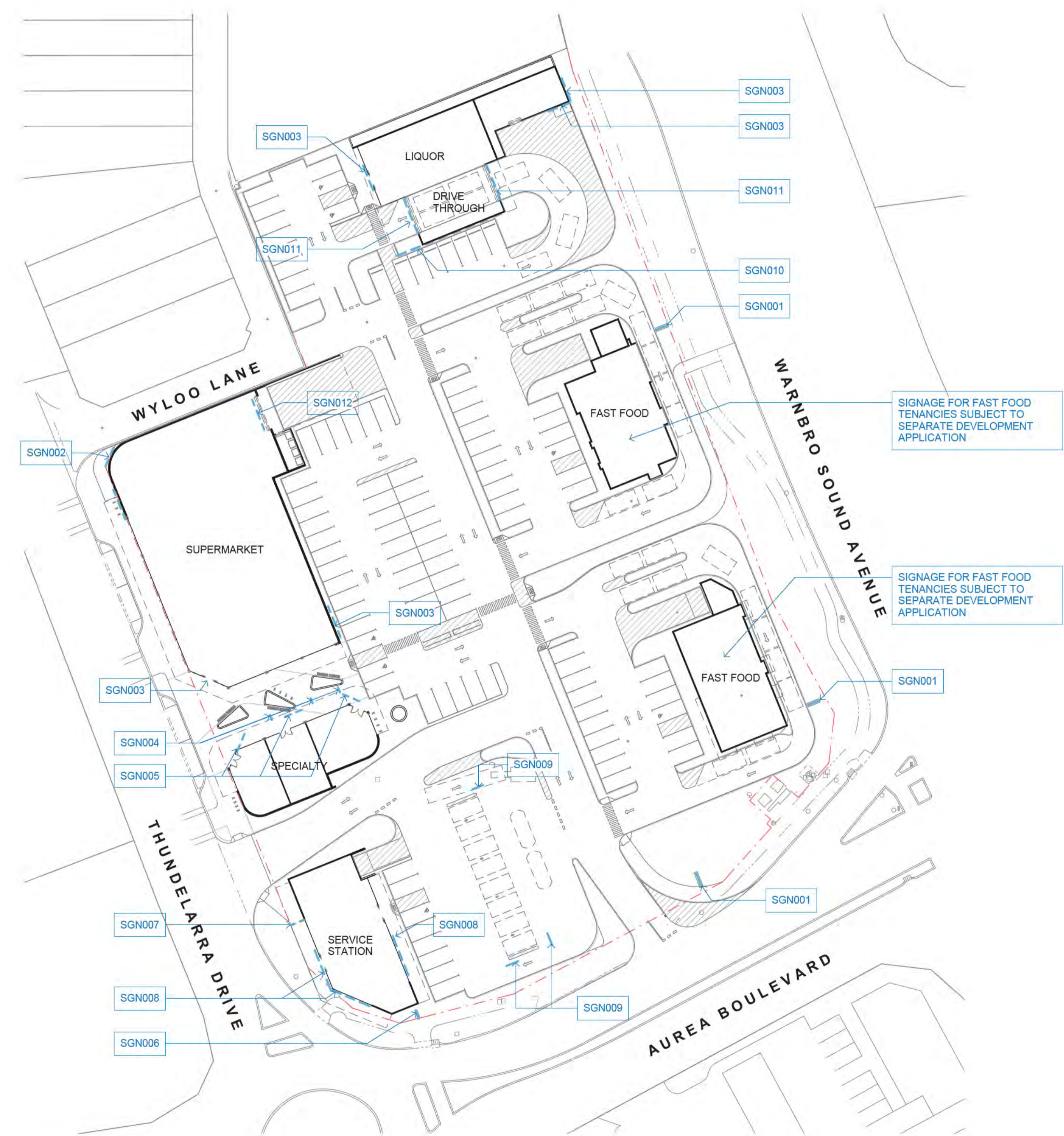

KEY PLAN - SIGNAGE
1 : 500



MASONRY-LOOK



TIMBER-LOOK CLADDING TO
SHOPFRONT

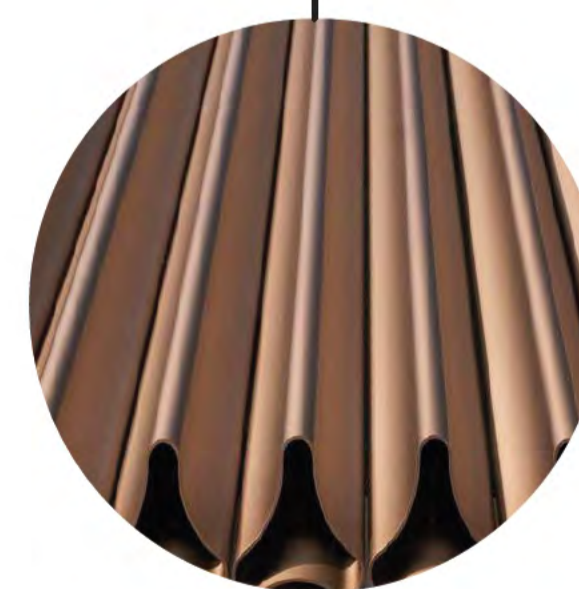

PROFILED METAL CLADDING

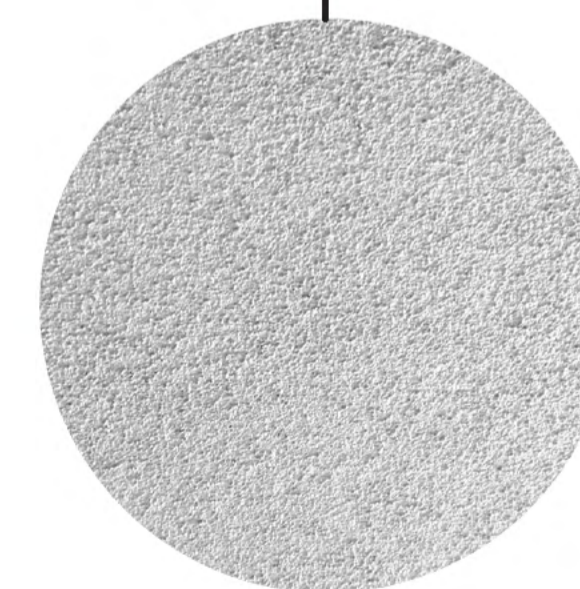

TEXTURED CONCRETE RENDER



PATTERNED CONCRETE PANEL

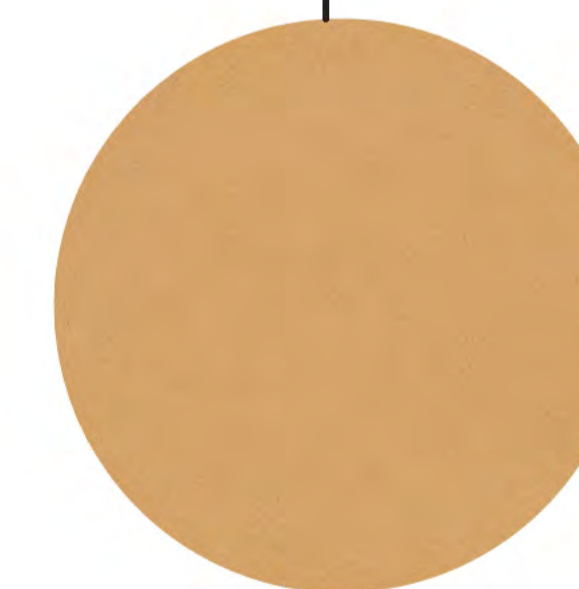

BRONZE FIBRE CEMENT
CLADDING

DEVELOPMENT
ASSESSMENT PANEL

APPROVED
12-Mar-2024



FEATURE METAL SCREEN
& TRELLIS

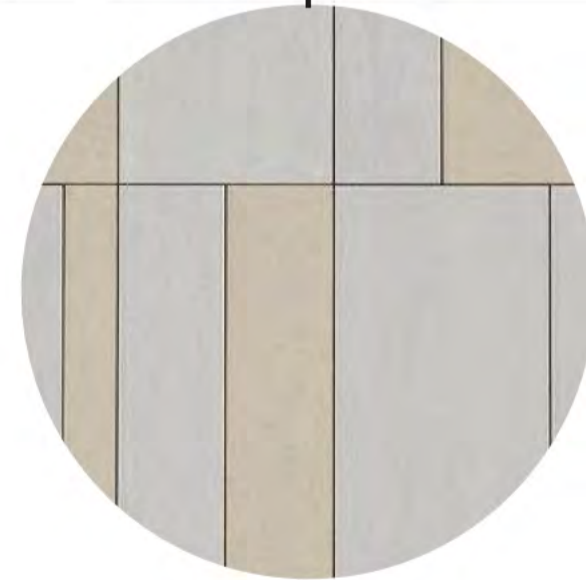

TILT-UP CONCRETE PANELS

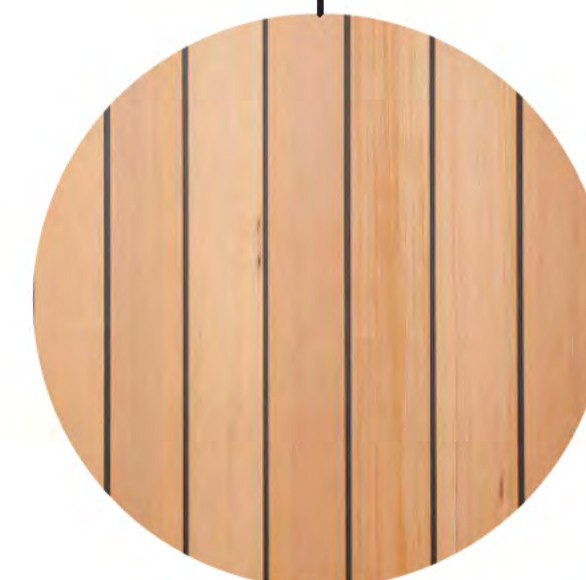

TIMBER-LOOK CLADDING

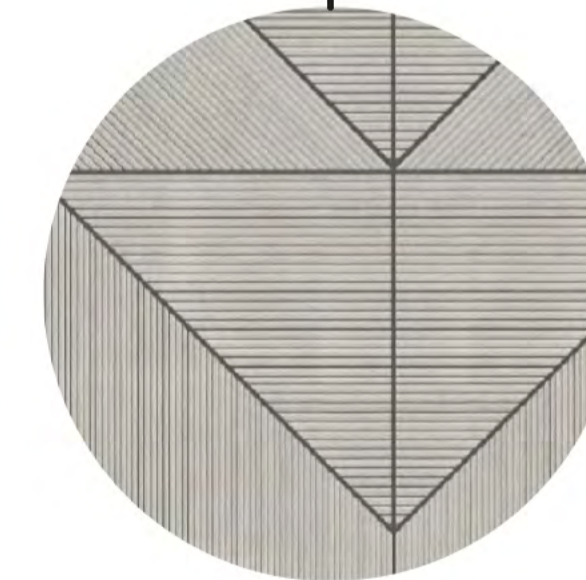

PATTERNED CONCRETE
PANELS



METAL PERFORATED SCREEN

**DEVELOPMENT
ASSESSMENT PANEL**

APPROVED
12-Mar-2024

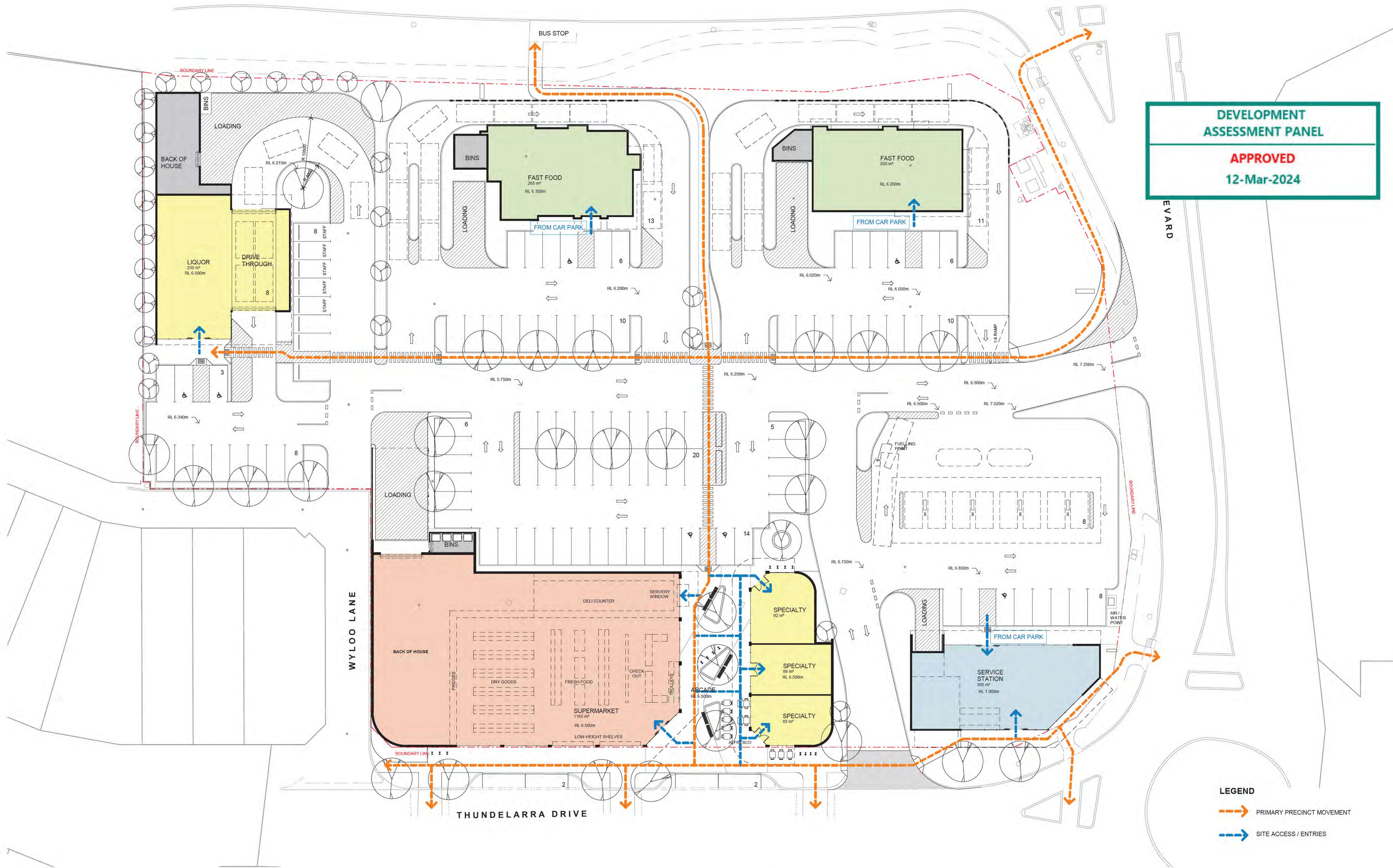

LEGEND

—> PRIMARY PRECINCT MOVEMENT

—> SITE ACCESS / ENTRIES

OVERALL LANDSCAPE SITE PLAN



LEGEND

- 01 LANDSCAPE PLAZZA AREA - REFER TO ENLARGED PLAN
- 02 EXPOSED AGGREGATE CONCRETE TO SUPERMARKET & SPECIALITY STORES
- 03 INSITU CONCRETE PAVEMENT TO CARPAK PATHWAYS
- 04 LOW - MEDIUM NATIVE COASTAL STYLE PLANTING
- 05 SMALL - MEDIUM TREES TO CAR PARK (AGONIS FLEXUOSA)
- 06 MEDIUM TO LARGE TREES TO BUFFER CARPAK TO ADJACENT ROADWAY (ALLOCASUARINA FRASERIANA)
- 07 LOW TO MEDIUM NATIVE COASTAL STYLE PLANTING WITH SMALL TREES (EUCALYPTUS ERYTHROCORYS)
- 08 EXISTING FOOTPATH TO BE RETAINED
- 09 FOOTPATH CONNECTION FROM WARNBRO SOUND AVENUE TO CAR PARK
- 10 RETAIN & PROTECT EXISTING LANDSCAPE BUFFER
- 11 FEATURE NORFOLK ISLAND PINE TREES WITH UPLIGHTING AT ENTRY
- 12 SMALL TREES COLUMNAR TREES TO GARDEN BED WITH LOW NATIVE PLANTING
- 13 RAISED PLANTER WITH SCREENING TREES TO ADJACENT RESIDENTIAL (MAGONLIA LITTLE GEM)

LOT 622(2) AUREA BOULEVARD, GOLDEN BAY

LANDSCAPE CONCEPT PLAN
APRIL 2023

**DEVELOPMENT
ASSESSMENT PANEL**

APPROVED
12-Mar-2024

JOB NO. 2215201
1:250 @ A1

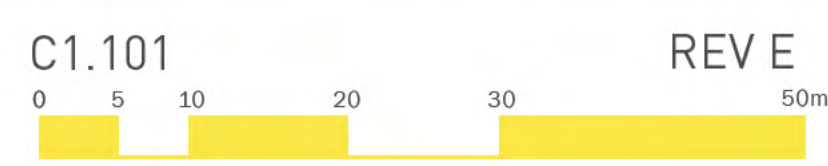

COPYRIGHT THIS DOCUMENT IS AND SHALL REMAIN THE PROPERTY OF PLAN E



LANDSCAPE ARCHITECTS

414 ROKEBY RD SUBIACO WA 6008
T: (08) 9388 9566 E: mail@plane.com.au

LANDSCAPE PIAZZA CONCEPT PLAN



LEGEND

- 01 EXPOSED AGGREGATE (COLOUR 1) CONCRETE TO SUPERMARKET AND SHOPS SURROUNDS
- 02 PROPOSED UNIT PAVERS ON CONCRETE SLAB TO ALFRESCO SEATING AREA & OUTSIDE OF SHOP FRONTS
- 03 PROPOSED TIMBER LOOK PAVERS ON CONCRETE SLAB TO DEFINE CENTRAL PATH
- 04 LIMESTONE WALL/ RAISED PLANTERS WITH COASTAL STYLE PLANTING
- 05 PROPOSED BENCH SEATS
- 06 PROPOSED CAFE FURNITURE LOCATION
- 07 PROPOSED BIKE RACKS
- 08 PROPOSED BIN LOCATION
- 09 FEATURE TREES I.E. NORFOLK ISLAND PINE TO DEFINE ENTRY
- 10 SMALL SHADE TREES TO RAISED PLANTERS (EUCALYPTUS ERYTHROCORYS)
- 11 NATIVE COASTAL STYLE PLANTING
- 12 INSITU CONCRETE PATH TO CAR PARK
- 13 PROPOSED PAVED CROSSOVER

LOT 622(2) AUREA BOULEVARD, GOLDEN BAY

DEVELOPMENT
ASSESSMENT PANEL

APPROVED
12-Mar-2024

LANDSCAPE CONCEPT PLAN
APRIL 2023

JOB NO. 2215201
1:100 @ A1

C1.102
0 5 10 20 30 50m
REV E

COPYRIGHT THIS DOCUMENT IS AND
SHALL REMAIN THE PROPERTY OF
PLAN E



LANDSCAPE ARCHITECTS

414 ROKEBY RD SUBIACO WA 6008
T: (08) 9388 9566 E: mail@plane.com.au

MATERIALS & PLANTING PALETTE



EXPOSED AGGREGATE CONCRETE

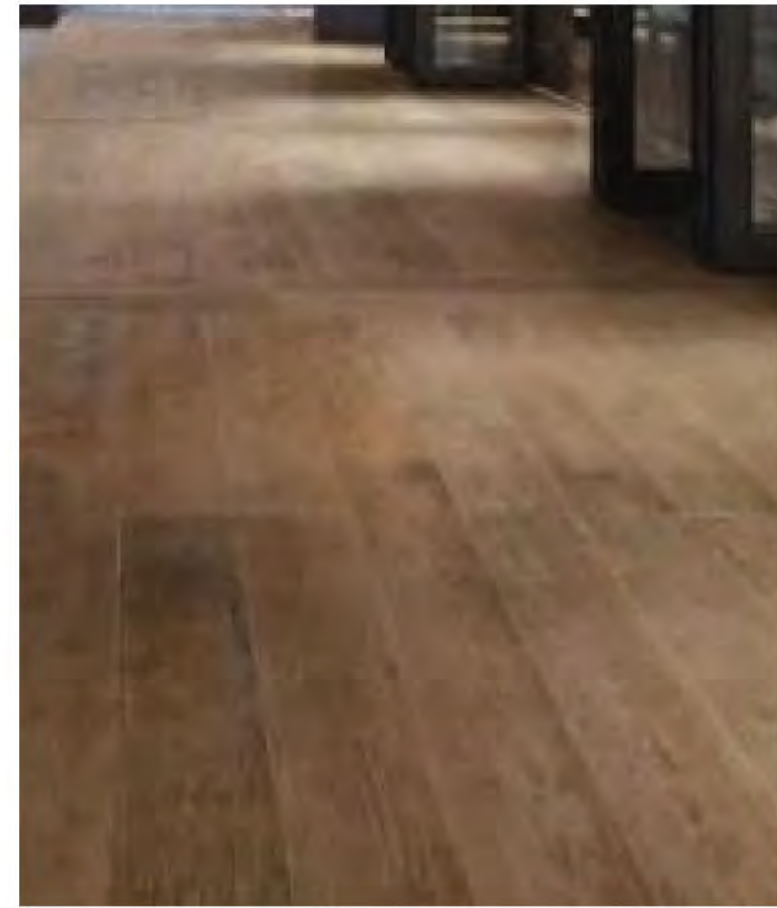

TIMBER LOOK PAVERS

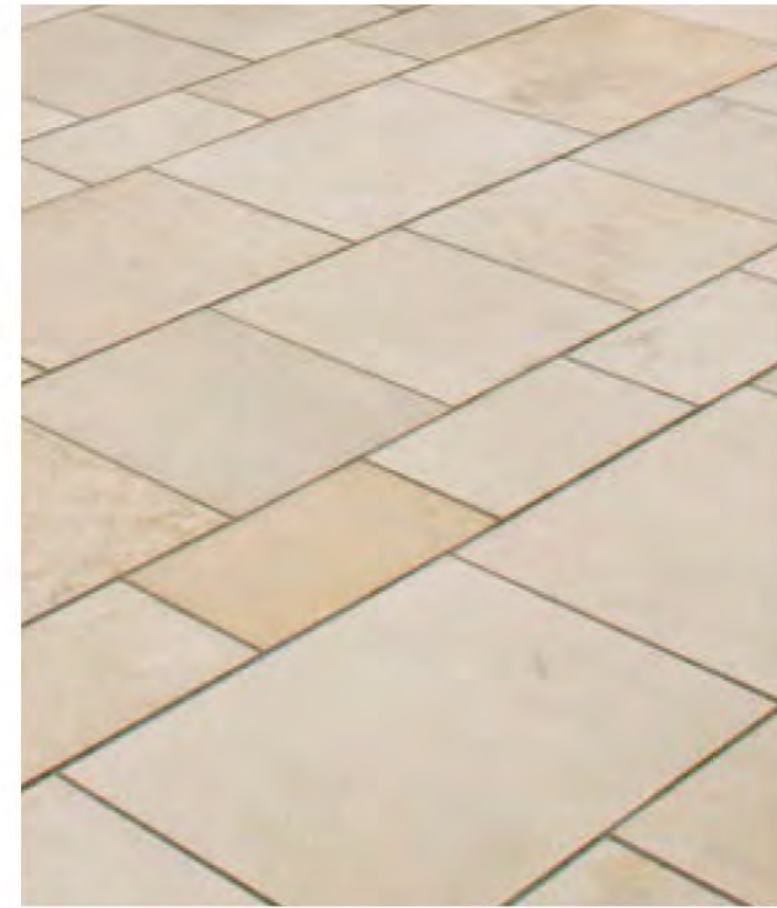

FEATURE UNIT PAVERS



BENCH SEATING



RUBBISH BIN



BIKE RACK



LIMESTONE WALL TO PLANTER



ARAUCARIA HETEROPHYLLA



ALLOCASUARINA FRASERIANA



AGONIS FLEXUOSA



EUCALYPTUS ERYTHROCORYS



MAGNOLIA LITTLE GEM



WESTRINGIA NARINGA



HYPOCALYMPMA ANGUSTIFOLIUM



RHAGODIA BACCATA



LEUCOPHYTA SILVER NUGGET



CONOSTYLIS CANDICANS



CAROBROTUS VIRESCENS



ANIGOZANTHOS SPP



WESTRINGIA MUNDI



SCAEVOLA AEMULA



ADENANTHOS SERICEUS COMPACT

LOT 622(2) AUREA BOULEVARD, GOLDEN BAY

LANDSCAPE CONCEPT PLAN
APRIL 2023

**DEVELOPMENT
ASSESSMENT PANEL**

APPROVED
12-Mar-2024

JOB NO. 2215201

C1.103

REV E

COPYRIGHT THIS DOCUMENT IS AND
SHALL REMAIN THE PROPERTY OF
PLAN E

**PLAN
E**

LANDSCAPE ARCHITECTS
414 ROKEBY RD SUBIACO WA 6008
T: (08) 9388 9566 E: mail@plane.com.au

Golden Bay Neighbourhood Centre

Application for Planning Approval



Lot 622 (2) Aurea Boulevard, Golden Bay

DEVELOPMENT
ASSESSMENT PANEL
APPROVED
12-Mar-2024

February 2023

apex
planning

Development Application

Lot 622 (2) Aurea Boulevard, Golden Bay

Prepared for Jarra Dev Pty Ltd

DOCUMENT CONTROL

DESCRIPTION	DATE
230217 22-083 DA report - Golden Bay (rev0).docx	17 February 2023

Apex Planning

Phone: 0416 672 501

Email: admin@apexplanning.com.au

Address: 3/128 Main Street, Osborne Park 6017

© 2023 Apex Planning Pty Ltd

All rights reserved. The information contained in this document and its appendices is confidential and intended solely for the use of the client for the purpose it was prepared. This document remains the intellectual property of Apex Planning Pty Ltd. This document may not be used, sold, reproduced or copied by any person without the prior written consent of Apex Planning Pty Ltd. The use or copying of this document in whole or in part without the written permission of Apex Planning Pty Ltd constitutes an infringement of copyright. No liability is accepted whatsoever for any unintended third party use or reliance on this report.



CONTENTS

1	INTRODUCTION	1
1.1	PRE-LODGEMENT ENGAGEMENT	1
2	LAND DESCRIPTION	3
2.1	LOT DETAILS	3
2.2	PREVIOUS APPROVAL	3
3	CONTEXTUAL CONSIDERATIONS	4
3.1	REGIONAL CONTEXT	4
3.2	LOCAL CONTEXT	4
3.3	SITE CONDITIONS AND TOPOGRAPHY	6
4	DESCRIPTION OF PROPOSAL	7
4.1	MAIN STREET RESPONSE (THUNDELARRA DRIVE)	8
4.2	WARNBRO SOUND AVENUE RESPONSE	8
4.3	AUREA BOULEVARD RESPONSE	9
4.4	LANDSCAPING ARRANGEMENTS	9
4.5	TRAFFIC ASSESSMENT	10
4.6	ACOUSTIC COMPLIANCE	11
4.7	EMISSIONS IMPACT ASSESSMENT (SERVICE STATION)	11
5	STATUTORY PLANNING ASSESSMENT	12
5.1	METROPOLITAN REGION SCHEME (MRS)	12
5.2	STATE PLANNING POLICY 4.2: ACTIVITY CENTRES	12
5.3	STATE PLANNING POLICY 7.0: DESIGN OF THE BUILT ENVIRONMENT	12
5.4	CITY OF ROCKINGHAM LOCAL PLANNING SCHEME NO. 2 (LPS2)	12
5.4.1	ZONING	12
5.4.2	LAND USE PERMISSIBILITY	13
5.4.3	PARKING ASSESSMENT	13
5.4.4	SCHEME REQUIREMENTS (COMMERCIAL ZONE)	15
5.4.5	MATTERS TO BE GIVEN DUE REGARD	16
5.4.6	DEVELOPMENT CONTRIBUTION AREA NO.2 (DCA2)	19
5.5	GOLDEN BAY STRUCTURE PLAN	19
5.6	GOLDEN BAY LOCAL DEVELOPMENT PLAN (LDP)	20
5.7	LPP 3.1.2 LOCAL COMMERCIAL STRATEGY	24
5.8	LPP 3.3.1 CONTROL OF ADVERTISEMENTS	26
5.9	LPP 3.3.9 FAST FOOD OUTLETS	27
5.10	LPP 3.3.14 BICYCLE PARKING AND END OF TRIP FACILITIES	28
5.11	LPP 3.3.25 PERCENT FOR ART	28
5.12	LPP 3.4.3 URBAN WATER MANAGEMENT	29
5.13	EPA GUIDANCE STATEMENT NO. 3	29
6	CONCLUSION	31

APPENDICES

APPENDIX 1:	CONCEPTUAL SKETCH PLAN
APPENDIX 2:	CERTIFICATE OF TITLE AND DEPOSITED PLAN
APPENDIX 3:	DEVELOPMENT PLANS
APPENDIX 4:	LANDSCAPE CONCEPT
APPENDIX 5:	TEN PRINCIPLES ASSESSMENT
APPENDIX 6:	TRAFFIC IMPACT ASSESSMENT
APPENDIX 7:	ENVIRONMENTAL NOISE ASSESSMENT
APPENDIX 8:	EMISSIONS IMPACT ASSESSMENT



1 INTRODUCTION

Apex Planning has produced this application for planning approval on behalf of Jarra Dev Pty Ltd, with regard to the proposed Golden Bay neighbourhood centre located at Lot 622 (2) Aurea Boulevard, Golden Bay (hereafter referred to as the **development site**).

The proposal seeks to establish a vibrant neighbourhood activity centre on the site, which appropriately responds to the contextual characteristics of the locality and delivers a range of complementary commercial uses which will cater for the daily and weekly needs of the surrounding community.

The neighbourhood centre is comprised of a local supermarket with specialty outlets, fuel station, liquor store, and fast food facilities which are designed to a high architectural standard to deliver the outcomes envisaged by the Golden Bay structure plan and associated local development plan.

The development will activate land which is currently vacant/derelict (and contains the remnant structures of an uncompleted previous development), significantly improving local amenity and access to key urban support services for the local area.

The proposed development has significant planning merit and warrants the support of the local authority, and the approval of the Metro Outer JDAP.

1.1 PRE-LODGEMENT ENGAGEMENT

Considerable pre-lodgement engagement has occurred with the officers of the City of Rockingham with regard to the proposed development.

On 8th July 2022, representatives of the proponent and Apex Planning attended an early project consultation meeting with the City of Rockingham, where a conceptual sketch notionally depicting the proposed land uses was presented for discussion and feedback. A copy of the initial concept plan is provided as **Appendix 1** for reference.

The development proposal was discussed in the context of the key requirements of the applicable structure plan / local development plan, including:

- The size of the supermarket component, and the relationship of the core retail areas with Thundelarra Drive (the 'main street').
- The need for the service station retail building to achieve suitable activation and aesthetic requirements due to the key corner location at Aurea Boulevard / Thundelarra Drive.
- The size and position of the piazza component.
- The importance of landscaping throughout the development site.
- The nature of the proposed land uses, in particular the service station and drive-through fast food outlets.
- Key expert input required for the development, including vapour assessment for the service station.



The need for pre-lodgement consideration by the City's Design Review Panel (**DRP**) was also discussed at the meeting, though it was subsequently decided by the City after the meeting that no consideration by the City's DRP would be necessary.

On 3rd October 2022, a design review package containing revised plans and an assessment against the principles of *State Planning Policy 7.0 Design of the built environment (SPP7)* was submitted to the City for comment.

Feedback was subsequently received on the package on 31st October 2022, which was given close consideration and resulted in further changes to the development.

Overall, the following changes were made to the development proposal as a result of the pre-lodgement process with the local authority, since the initial project meeting in July 2022:

- Expansion of the size of the supermarket component to 1,165sqm.
- Reorientation and redesign of the supermarket building to provide more meaningful frontage and activation to Thundelarra Drive, and screening of the car park from the street.
- Reorientation and redesign of the speciality tenancies to better connect with the supermarket and enable a larger and more meaningful arcade/piazza.
- Repositioning and expansion of the piazza/arcade to establish a better pedestrian connection via Thundelarra Drive and create a link between the supermarket and specialty tenancies.
- Enhancement of the service station through feature aesthetic form and more activation to Thundelarra Drive.
- Further development of landscape architecture to optimise areas for tree and screen planting around the site.
- Reduction of service station refuelling component to four bowsers rather than eight bowsers.
- Enhancement of the fast food facilities, in particular the extent of articulation and structural aesthetic screening for the drive-through components.
- Establishment of stronger pedestrian links throughout the site, via a series of internal pathways and zebra crossings.

In summary, the pre-lodgement process with the local authority has enabled the form, aesthetics, activation and function of the development proposal to be optimised.



2 LAND DESCRIPTION

2.1 LOT DETAILS

The land subject of this application for planning approval is described in **Table 1** below.

Table 1: Lot details					
Lot	Deposited Plan	Volume	Folio	Lot area	Ownership
622	408508	2898	430	1.2398ha	Golden Bay Village Pty Ltd

The Certificate of Title (**CT**) and Deposited Plan are provided at **Appendix 2**. There is only one encumbrance on the CT, which relates to an easement to Water Corp and is depicted on the Deposited Plan. No development is proposed within this easement.

2.2 PREVIOUS APPROVAL

On 29th June 2016, the City granted development approval to the 'Golden Bay Village Centre' on the site.

Based on the approval letter and stamped plans, the key elements of the previous approval are noted as follows:

- A supermarket of 1,050sqm, small retail tenancies totalling 1,115sqm, a standalone liquor store of 280sqm, and a medical facility with 6 consulting rooms. The applicable parking requirement is 176.7 bays based on the requirements contained within *Table No. 2 – Carparking Table* of Local Planning Scheme No.2.
- Parking provision of 153 parking spaces within the site and six onstreet parking spaces.
- An approved parking shortfall of approximately 17.7 bays.
- Vehicular access via Wyloo Lane and Thundelarra Drive.

Based on aerial imagery, construction of the village centre commenced in mid 2017, which involved site works, concrete slabs for some buildings, steel structures for some buildings, access and drainage infrastructure.

However, construction never progressed past this stage and the improvements have remained on the site since commencement.

3 CONTEXTUAL CONSIDERATIONS

The following sub-sections describe the contextual characteristics of the site. Refer to **Figure 1: Aerial Photo**, which illustrates the development site and surrounds.

3.1 REGIONAL CONTEXT

The development site is in the City of Rockingham and is approximately:

- 52km south of the Perth CBD
- 14.5km south of the Rockingham Strategic Centre
- 13km north of the Mandurah Strategic Centre

The development site has frontage to the following roads:

- Warnbro Sound Avenue, an Other Regional Roads reserve under the MRS and a District Distributor A under the structure plan.
- Aurea Boulevard, a Local Distributor under the Main Roads hierarchy and an Integrator B under the structure plan where it adjoins the development site.
- Thundelarra Drive, an Access Road under the Main Roads hierarchy and a Neighbourhood Connector B under the structure plan where it adjoins the development site.

Warnbro Sound Avenue is a key transport route for the coastal area generally west of Ennis Avenue / Mandurah Road, providing the communities of Warnbro, Port Kennedy, Secret Harbour and Golden Bay with a connection between Safety Bay Road (north) and Mandurah Road (south).

3.2 LOCAL CONTEXT

The development site forms part of the Golden Bay neighbourhood centre precinct, which is comprised of six separate lots zoned 'Commercial' under the City's LPS2 and indicated as such under the Golden Bay structure plan (extract provided below):

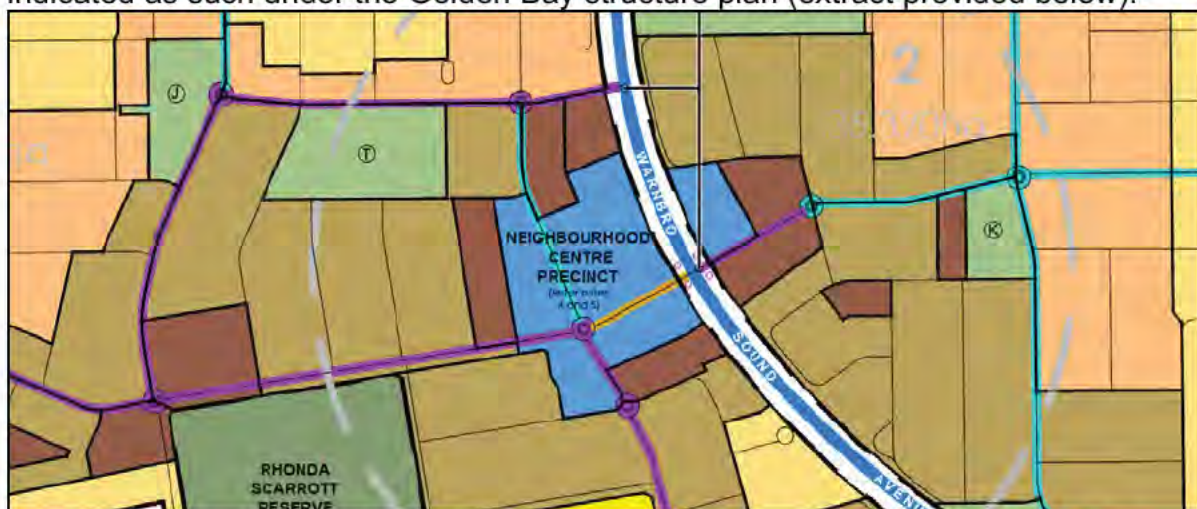

Image extract: the Neighbourhood Centre Precinct as shown on the Golden Bay Structure Plan.





Figure 1: Aerial Photo / Context Map



NORTH

Drawn: Alessandro Stagno

Rev: 0

Source: MNG Access

Date: 31 January 2023

Lot 622 (2) Aurea Boulevard, Golden Bay

apex
planning

DEVELOPMENT

The development site is the largest and centrally located lot of the neighbourhood centre precinct and is bounded on three sides by roads (Warnbro Sound Avenue, Aurea Boulevard, Thundelarra Drive).

The site benefits from frontage to the highest order roads in the structure plan area (affording a high level of exposure), as well as frontage to Thundelarra Drive which is intended to form the 'main street' of the locality.

The Golden Bay locality is bisected by Warnbro Sound Avenue, and has been in the process of urbanisation in accordance with the Golden Bay Structure Plan since the early 2010s. Residential development of densities generally ranging from R20-R80 has emerged throughout the area.

The Golden Bay neighbourhood centre precinct is approximately 1.2km south of the Secret Harbour district centre, which is located at the intersection of Warnbro Sound Avenue / Secret Harbour Boulevard. The district centre contains three major supermarkets, as well as supplementary liquor, fuel, and other associated specialty shops and serves a significant catchment.

In terms of immediate surroundings:

- The development site is bounded by Wyloo Lane to the north-west, with housing located beyond.
- The development site adjoins vacant residential land to the north, currently identified as Lot 9505.
- The development site is bounded by Warnbro Sound Avenue to the east, which is comprised of six lanes of traffic and a wide verge immediately opposite the site. Traffic data from 2022 indicates Warnbro Sound Avenue carried approximately 9,700 daily vehicles in the vicinity of the site.
- The development site adjoins the major signalised intersection of Warnbro Sound Avenue / Aurea Boulevard / Adelong Avenue to the south-east, which affords controlled full-movement access into the Golden Bay estate.
- The development site is bounded by Aurea Boulevard to the south, which is comprised of four lanes of traffic (including slip lanes). Traffic data from 2022 indicates Aurea Boulevard carried approximately 3,182 daily vehicles in the vicinity of the site.
- A recently completed mixed commercial development exists on Lot 1523 adjacent to the site to the south, which contains a 24 hour service station, gym, and commercial building.
- The development site adjoins the roundabout intersection of Aurea Boulevard and Thundelarra Drive to the south-west. Childcare facilities are present on both sides of the roundabout, fronting Thundelarra Drive.
- A large, vacant commercial site (Lot 636) is adjacent the development site on the western side of Thundelarra Drive.



In terms of public transport, the 558 route operates along Warnbro Sound Avenue with a stop located within the verge immediately adjacent the development site. The 558 route provides a connection between Mandurah and Rockingham, operating on a half hourly basis throughout the day with additional services providing during the peak hour. The route provides a connection to Rockingham train station and Warnbro train station, affording a reasonably good level of transit connectivity.

3.3 SITE CONDITIONS AND TOPOGRAPHY

The development site is currently in a derelict condition, resulting from the partial completion of a formerly approved 'village centre' development.

The site currently contains various concrete pads, steel frame structures, a crossover to Thundelarra Drive and drainage infrastructure which formed the early phases of construction, and appear to have remained on the site since 2017.

In terms of topography, this varies as some areas of the site appear to have been subject to site works as part of the aforementioned approval. These areas are generally flat with gentle grades. There are also some existing mounds throughout the site which are around 1.5m-2m higher than natural ground level.

According to mapping, the development site appears to have access to the necessary urban utilities services.



4 DESCRIPTION OF PROPOSAL

Refer to **Appendix 3** for the full set of development plans (including 3D images), **Appendix 4** for the landscape concept plan, and **Appendix 5** for an assessment against the ten principles of SPP7.0.

The proposal seeks to establish a vibrant neighbourhood centre on the site, which delivers a range of complementary commercial uses to cater for the daily and weekly needs of the surrounding community in accordance with the Golden Bay structure plan.

The development will significantly improve the site's relationship with the surrounding area and will enhance local visual amenity, by replacing what exists on the site with an attractively designed neighbourhood centre which is accessible both by foot and by car.

The proposed neighbourhood centre development includes the following land uses:

- A supermarket of 1,165sqm, operating during typical supermarket hours.
- Three speciality tenancies totalling 255sqm, likely operating morning / daytime / evening.
- A service station with 320sqm retail building and 4x fuel bowsers, operating 24 hours.
- Two drive-through fast food outlets of 265sqm and 260sqm, operating 24 hours.
- A small liquor store of 230sqm with a drive-through component, operating 9am-10pm.

The layout and configuration of the development aligns with the structure plan and local development plan prepared for the area, with access / driveways / landscaping / built form generally positioned in the areas indicated (albeit with some minor variance).

The proposed neighbourhood centre is arranged to appropriately respond to its surroundings, addressing the 'main street' design intention for Thundelarra Drive, the regional road function of Warnbro Sound Avenue, and the Integrator B function of Aurea Boulevard.

The site's vehicular access points are via Wyloo Lane, Thundelarra Drive, and Aurea Boulevard, all linking to a main internal driveway which provides connection to each facility. Total parking availability will be 151 bays (including 6 onstreet bays), which will be used reciprocally. Strong pedestrian linkages are established throughout the car parking areas with raised pathways, pram ramps and zebra crossings.

Buildings are deliberately positioned along road frontages with the car park in the centre of the site, as a means of creating built form presence to the frontage roads and screening the car park from the public realm. Landscape integration plays a key role in the architectural approach for the neighbourhood centre, using landscape features, screen planting, and raised planters as a means of establishing a sensitive interface with each boundary frontage.



4.1 MAIN STREET RESPONSE (THUNDELARRA DRIVE)

An engaging 'main street' is established along Thundelarra Drive, with an attractively designed pedestrian precinct comprised of the supermarket, speciality tenancies and central arcade/piazza. Buildings comprise street-edge setbacks to Thundelarra Drive and the piazza/arcade.

The buildings facing Thundelarra Drive and the arcade are articulated/treated with high quality materials reflective of the coastal context and pedestrian-level windows / openings which afford mutual views to the street and arcade for a high level of engagement.

The arcade provides a quality pedestrian thoroughfare between Thundelarra Drive and the car park, funnelling pedestrians through a pleasant urban space from the street and encouraging foot traffic to pass the specialty tenancies. The arcade aligns with the main internal pedestrian path through the site, connecting through to the bus stop on Warnbro Sound Avenue for optimised accessibility.

Alfresco seating within the arcade is protected with raised planters to create a comfortable environment for patrons seeking to linger and socialise over a coffee or meal.

The proposed service station is positioned at the corner of Thundelarra Drive and Aurea Boulevard and is intended to create a corner presence through accentuated height, variation in materials, and feature roof form with structural expression.

The service station building addresses both of its frontages, with full height windows and pedestrian entry points at the forecourt and facing Thundelarra Drive. Whilst a key function is to offer the retail sale of fuel, the retail building also serves an important convenience function and is expected to provide local residents with uninterrupted access to essential goods on a 24 hour basis, providing significant passive surveillance and night-time activity as part of CPTED principles.

Built form treatments, materiality and colour tones are coastal in nature, taking keynotes from existing local examples, seaside undertones, and key principles adopted from the Golden Bay design guidelines enforced by the estate developer for the surrounding area.

4.2 WARNBRO SOUND AVENUE RESPONSE

The three drive-through facilities (liquor and two fast food outlets) are appropriately positioned along the Warnbro Sound Avenue frontage, which affords visibility/exposure to the high number of daily vehicles using this key regional road whilst allowing the pedestrian focused uses to be located along Thundelarra Drive.

Each facility is separated by raised kerbing with intuitive circulation systems and Australian Standards compliant car parking areas to ensure efficient and coordinated movement at all times.



Visual amenity is given priority along Warnbro Sound Avenue, though landscape screening adjacent to the liquor store and the use of structural feature screening along the drive-through areas of the fast food outlets with integrated landscape planting.

The fast food outlet located at the corner of Warnbro Sound Avenue / Aurea Boulevard includes a transitioned feature screen comprised of battens which increase in height as they wrap around the curve of the drive-through, creating visual interest.

All three facilities provide varied roof forms, alternating colours/materials, and shopfront windows, ensuring design quality across the site is at the optimal standard.

4.3 AUREA BOULEVARD RESPONSE

The response to Aurea Boulevard has been informed by key contextual considerations, to ensure a practical and realistic approach is adopted.

The existence of three lanes with a solid central median for most of the road frontage (as well as the proximity to a major signalised intersection for a regional road) makes this area less conducive to built form or meaningful activation, and more suitable for access and car-based activity.

A central access point restricted to left-in/left-out (**LILLO**) movements is a logical response, as traffic adjoining the site flows toward the nearby signalised intersection (affording low-conflict in and out movements) and enables better dispersion of traffic through the site. The access point also reduces the number of service vehicle movements along Thundelarra Drive, strengthening its function as a 'main street'.

The positioning of the service station with frontage to this road maintains consistency with the layout of the recently completed development on the southern side of Aurea Boulevard, whilst optimising accessibility to the refuelling area due to its connection to driveways and crossovers.

A large landscape entry feature is provided at the eastern side of the proposed crossover, which screens views into the car park and enhances the 'sense of arrival' as traffic moves into the area from Warnbro Sound Avenue.

4.4 LANDSCAPING ARRANGEMENTS

A conceptual landscape plan depicting landscape arrangements throughout the neighbourhood centre is provided at **Appendix 4**. The landscape plan was formulated by PlanE and includes:

- A generous landscape feature area next to the site's Aurea Boulevard crossover which will include a feature Norfolk Island pine tree with uplighting as a keynote to the site's coastal location.
- Landscape planting along the Warnbro Sound Avenue frontage to enhance the site's relationship to this regional road, comprised of suitable trees and low planting species.

- Significant tree planting throughout the car park to reduce the urban heat island effect and optimise the provision of greenery within this space.
- Enhancements to the verge, including the planting of additional verge trees along Thundelarra Drive to enhance the 'main street' feel of this area.
- The use of a coastal-inspired hardscape treatment and raised planters within the piazza/arcade, which allow the planting of attractive native tree species and enhance the amenity of the space of users of the alfresco areas.
- The Thundelarra Drive accessway containing trees and low-level planting to contribute toward a sense of place and screen side/rear elevations of the speciality tenancies and service station retail building.
- Landscape buffer planting within the northern setback area of the liquor store. The buffer planting is provided on a raised planter, which not only improves articulation and optimises soil volume, but also allows trees to more effectively screen buildings due to increased height.

The landscape arrangements for the proposed neighbourhood centre are appropriate and allow the facility to integrate with its surroundings.

4.5 TRAFFIC ASSESSMENT

The proposed development is supported by a comprehensive Traffic Impact Assessment (**TIA**) produced by Transcore, in accordance with the requirements of the WAPC traffic impact assessment guidelines. The TIA is provided at **Appendix 6**.

The key outcomes of the TIA are as follows:

- With regard to traffic generation, the TIA concludes that the net addition of AM and PM peak trip generation is 123 and 213 respectively, which is entirely capable of being accommodated by the surrounding road network.
- A SIDRA analysis of the nearby signalised intersection of Warnbro Sound Avenue / Aurea Boulevard and roundabout intersection of Aurea Boulevard / Thundelarra Drive confirms satisfactory operation in the post-development and 10-year scenarios, with no major change in current level of service. Importantly, both intersections retain ample spare capacity for future traffic growth.
- A SIDRA analysis of the proposed development crossovers demonstrates satisfactory operation in 2023 and 2033 during the peak hours, with good level of service and minimal delays and queuing.
- A stacking analysis for the service station demonstrates adequate queuing space for vehicles during peak periods of operation.
- The capacity of drive-through areas for both fast food outlets meets the requirements of the RTA guidelines.

The traffic assessment also considers parking supply and demand for the neighbourhood centre, analysing the need for bays based on the peak periods of operation for each land use. The analysis demonstrates that reciprocal use of bays will adequately cater for the needs of the overall development.



In relation to servicing, the TIA contains swept path plans demonstrating the satisfactory movements of service vehicles for each land use, including:

- 19m fuel tankers for the service station, capable of comfortably entering via Thundelarra Drive and exiting via Aurea Boulevard.
- 8.8m service vehicle for the two fast food outlets, capable of entering and exiting both fast food sites in forward gear.
- 8.8m service vehicle for the liquor store, capable of comfortably entering and exiting in forward gear. The drive-through canopy is purpose-designed to allow through movement of service vehicles.
- 12.5m service vehicle for the supermarket, capable of comfortably entering via Wyloo Lane and reversing into the loading area, and subsequently exiting in forward gear via Aurea Boulevard.

As evident from the swept path diagrams, a distinct advantage of the proposed LILO crossover to Aurea Boulevard is that the number of service vehicle movements on Thundelarra Drive is reduced, enhancing its function as a 'main street' precinct.

In summary, the TIA is comprehensive and demonstrates acceptable traffic/access outcomes associated with the development.

4.6 ACOUSTIC COMPLIANCE

An environmental noise assessment was produced by Lloyd George Acoustics in accordance with statutory requirements, noting the development site is within proximity of residential land and includes land uses which would operate outside of normal business hours. The acoustic report is provided at **Appendix 7**.

The assessment undertakes a conservative 'worst case' analysis of noise generated by each land use based on their intended hours of operation, and demonstrates compliance is readily achieved based on the details/information depicted on the development plans.

4.7 EMISSIONS IMPACT ASSESSMENT (SERVICE STATION)

Having regard for the proximity of the proposed 24 hour service station to sensitive properties, an emissions impact assessment was prepared to consider airborne pollutants against established standards. The assessment is provided at **Appendix 8**.

The assessment conservatively considers potential emissions from the service station, including potential cumulative impacts due to the existence of a service station on the opposite side of Aurea Boulevard.

The assessment demonstrates that the assessed airborne pollutants fall below guideline exposure standards, subject to the proposed service station employing both Stage 1 and Stage 2 vapour recovery systems. This is a matter which can be addressed as a condition of planning approval.

5 STATUTORY PLANNING ASSESSMENT

5.1 METROPOLITAN REGION SCHEME (MRS)

The development site is zoned Urban under the Metropolitan Region Scheme (**MRS**). The proposal involves the establishment of a commercial development on the site, which is consistent with the Urban zone of the MRS and warrants approval.

The site adjoins the Category 1 Warnbro Sound Avenue Other Regional Roads reservation. No direct access to Warnbro Sound Avenue is proposed.

5.2 STATE PLANNING POLICY 4.2: ACTIVITY CENTRES

SPP4.2 intends to ensure planning and development adequately considers the distribution, function and broad land use considerations for activity centres.

The Golden Bay neighbourhood centre was established through retail analysis and structure planning, in accordance with the principles and policy measures of SPP4.2.

The retail floorspace prescribed by the structure plan and its retail analysis for this neighbourhood centre was approximately 3,500sqm, across the entire neighbourhood centre precinct which is comprised of six separate lots zoned for commercial purposes under LPS2.

An assessment is appropriately provided against the City's Local Commercial Strategy and Golden Bay structure plan later in this report.

5.3 STATE PLANNING POLICY 7.0: DESIGN OF THE BUILT ENVIRONMENT

SPP7.0 addresses design quality and built form outcomes, seeking to deliver the range of benefits that derive from good design. A comprehensive visual and textual assessment against the ten principles of SPP7.0 is provided at **Appendix 5**.

5.4 CITY OF ROCKINGHAM LOCAL PLANNING SCHEME NO. 2 (LPS2)

5.4.1 ZONING

The development site is zoned Commercial under the City's LPS2. Refer to **Figure 2 – Zoning Map**. Under Clause 4.6.1 of LPS2, the objective of the Commercial zone is:

to provide for the development of District, Neighbourhood and Local shopping facilities to cater for the present and future residents of the City consistent with the local government's Local Commercial Strategy and supported by any other Plan or Policy that the local government from time to time may adopt as a guide for the future development within the Zone.



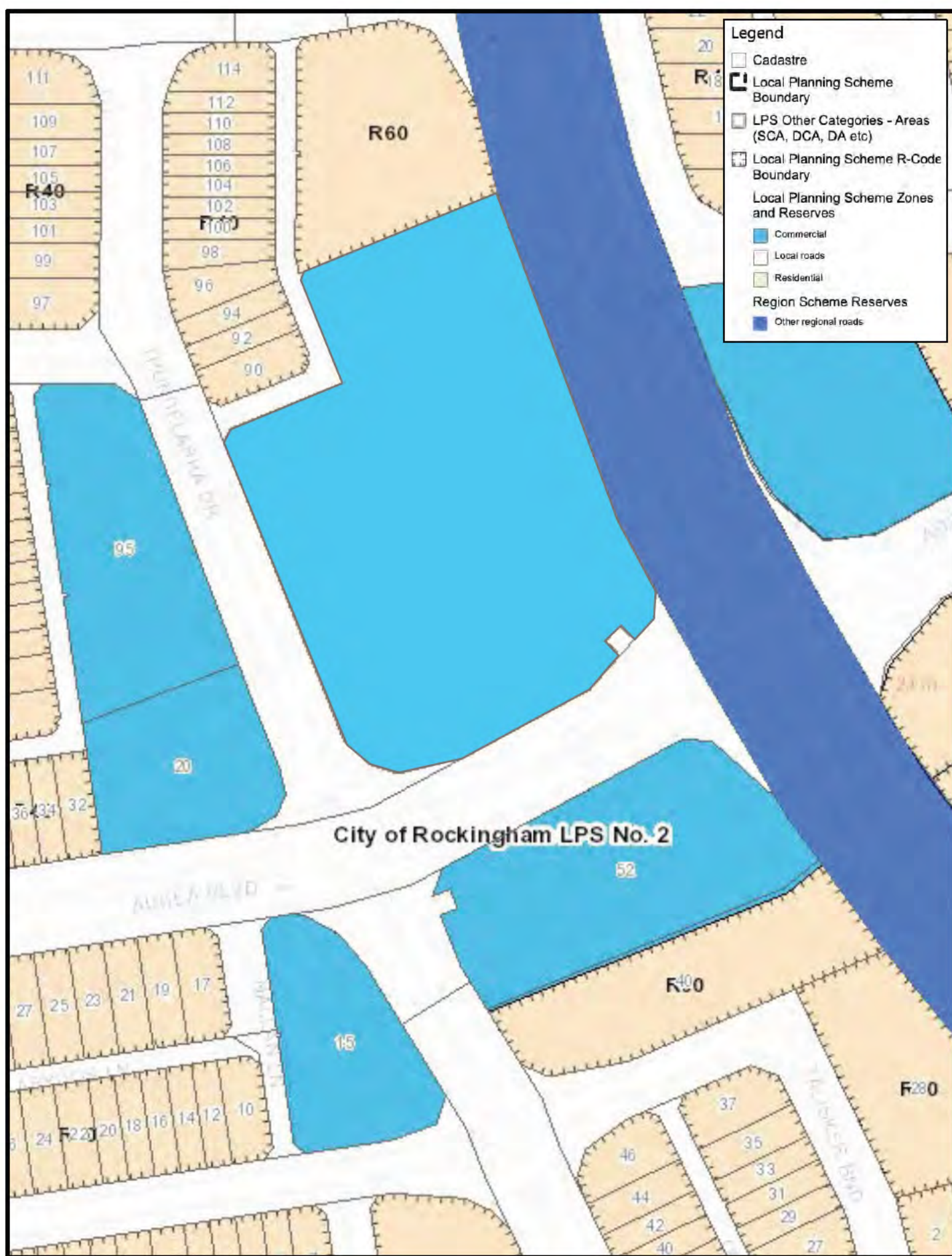

Figure 2: Zoning Map

Lot 622 (2) Aurea Boulevard, Golden Bay



NORTH

Drawn: Alessandro Stagno

Rev: 0

Source: PlanWA, City of Rockingham

Date: 31 January 2023

apex
planning

DEVELOPMENT

This proposal involves the establishment of a neighbourhood level shopping facility on the site which is comprised of a supermarket, specialty shops, liquor store, and fast food outlets. The total gross leasable retail area of the development is 2,495sqm.

The land use mix is consistent with what would be expected at a neighbourhood level centre catering for the daily and weekly needs of the local community, and extent of floorspace fits comfortably with the neighbourhood centre function of the site as set out in the state and local planning framework.

The site is also located within Development Area 14 (**DA14**) of LPS2, which sets the statutory basis for the Golden Bay structure plan and associated local development plan (both are addressed in the subsequent sections of this report).

5.4.2 LAND USE PERMISSIBILITY

The development site is zoned Commercial under the City's LPS2. The permissibility of the proposed uses in the Commercial zone is set out below:

Fast Food Outlet: 'D' discretionary

Liquor Store – Small: 'D' discretionary

Service Station: 'D' discretionary

Shop: 'P' permitted

The uses are all inherently commercial in nature and are consistent with the intent of the commercial zone. The proposed mix of uses is appropriate for a neighbourhood centre which would provide for the daily to weekly household shopping needs of the surrounding community, given its highly accessible location.

The layout and design of the proposed neighbourhood centre is responsive to the characteristics of the site and its surroundings, and features a high quality of architectural expression. The development is supported by a range of expert assessments demonstrating the suitability of the proposed uses on the site. The content of this report comprehensively demonstrates the development is consistent with the applicable planning framework.

With the above in mind, the proposed uses warrant approval.

5.4.3 PARKING ASSESSMENT

Table No. 2 – Carparking Table of LPS2 sets out the applicable parking requirement for the respective land uses proposed as part of this development. The requirements are as follows:

Fast Food Outlet: 1 bay per 11sqm NLA (including outdoor eating areas)

Liquor Store – Small: refer to shop

Service Station: 1 bay for every service bay, plus 1 bay per employee and 6 bays per 100sqm NLA of retail floorspace

Shop: 6 bays per 100sqm NLA



An assessment against the parking standards set out under LPS2 is provided in Section 7 of the TIA and extracted below:

Use	Required	Provided	Surplus / Shortfall (+/-)
Supermarket	70	50	-20
Specialty shops	16	5	-11
Fast Food outlets	49	46	-3
Service station	22	16	-6
Liquor store	18	27	+9
On-street bays		6	+6
Total theoretical shortfall considering the on-street bays			-25

The development creates a total theoretical shortfall of 25 bays, noting it is intended bays would be used reciprocally. The parking arrangements for this neighbourhood centre are acceptable and warrant the exercise of discretion for the following reasons:

- The TIA provides a detailed parking demand analysis between the various land uses and demonstrates that the proposed parking provision will adequately cater for the needs of the overall development, with a surplus of bays still available during the most intensive periods of usage.
- A shortfall of 17.7 bays was previously considered acceptable on the site as part of the development approval for the former village centre. A shortfall of 25 bays is not significantly greater than the shortfall previously considered.
- A considerable amount of patronage for the liquor store, fast food outlets, and service station is expected to use drive-through and/or refuelling facilities, which technically does not contribute toward the demand for marked parking spaces.
- The development encourages the use of alternate modes of transportation, noting a clear and direct connection to the adjacent bus stop is provided and 15 bicycle racks are provided throughout the site.
- Many patrons residing within the walkable catchment are expected to walk to the site to access the services offered.
- Multi-use trips are expected to occur, whereby patrons attending the site for one purpose would also use other services.

The proposed provision of bays meets the parking demand of the neighbourhood centre and warrants support.

5.4.4 SCHEME REQUIREMENTS (COMMERCIAL ZONE)

Table 2 below provides an assessment against the scheme requirements for the Commercial zone set out by Clause 4.6 of LPS2.

Table 2: scheme requirements (Commercial zone)	
Requirement	Response
<p>4.6.1 Objective The objective of the Commercial Zone is to provide for the development of District, Neighbourhood and Local shopping facilities to cater for the present and future residents of the City consistent with the local government's Local Commercial Strategy and supported by any other Plan or Policy that the local government from time to time may adopt as a guide for the future development within the Zone.</p>	<p>The development is consistent with the objective of the Commercial zone. Refer to earlier sections of this report, including Section 5.4.1.</p>
<p>4.6.2 Form of Development a) In considering applications for development approval in the Commercial Zone, the local government shall ensure that that site planning, scale, built-form, elevations and landscaping of the development positively contribute to the streetscape, appearance and amenity of the locality.</p>	<p>The proposed neighbourhood centre is configured and designed in a manner which appropriately addresses its context and immediate surroundings. This is explained in detail in Section 4 and further explained in the 'ten principles' assessment at Appendix 5.</p>
<p>4.6.3 Parking Provision shall be made for the on-site parking of motor vehicles in all development in the Commercial Zone in accordance with the provisions of clause 4.15 and Table No.2.</p>	<p>A parking assessment is provided in Section 5.4.3 of this TIA and Section 7 of the TIA, which demonstrate the parking arrangements for this neighbourhood centre are acceptable.</p>
<p>4.6.4 Setbacks In assessing applications for development approval, the local government shall take into account the following requirements when determining the setbacks for developments in the Commercial Zone:- a) where a development is proposed to be located on a lot having a common boundary with a Residential zoned lot or residential use class, the setbacks shall not be less than those prescribed in the R-Codes for the particular density code of the adjoining residential lot; b) in all other cases, setbacks to be determined by the local government taking into account the principles outlined in clause 4.6.2 and the requirements of the Building Code of Australia.</p>	<p>The development site adjoins land zoned Residential R60 along a portion of the northern boundary. Development along this boundary is comprised of the northern wall of the liquor store, which contains no windows. The wall is 38.3m long and transitions in height from 5.4m-6.9m. Under the R-Codes, the setback requirement would technically be 2.5m-3.3m. The interface with this adjoining property is addressed in the following manner:</p> <ul style="list-style-type: none"> • A setback of 1.88m-2.11m along the wall. • The wall divided into separate 'sections', which are treated with patterned concrete panels and cladded finish. • A raised planter containing screen vegetation which provides articulation along the boundary, as well as an elevated green buffer significantly screening the liquor store wall. <p>Setbacks throughout the remainder of the development were determined based on the context and character of the applicable frontage road, as explained in Section 4 of this report.</p>



4.6.5 Landscaping

a) Subject to b) below, within any development in a Commercial Zone a minimum of ten percent (10%) of the total site area shall be provided as landscaping in the form approved by the local government. The area of the site required to be provided under this sub-clause shall not include areas which would normally be set aside for pedestrian movement.

b) Where the provision of ten percent (10%) of the total site area as landscaping is not practicable, the local government may consider an equivalent contribution towards streetscape works in the public streets adjoining the property, based on the principles outlined in clause 4.6.2. Streetscape works may incorporate elements such as kerbside parking, pedestrian footpaths, soft landscaping, street trees, lighting and street furniture.

The development site provides approximately 1,050sqm of soft landscaping area (not including verge upgrades external to the site boundaries), which equates to 8.5% of the total site area.

The landscaping area provided onsite is substantial, and offers a practical solution toward:

- Accommodating significant trees throughout the car park, setback areas, and street frontages reducing the urban heat island effect and enhances amenity.
- Effective green buffer along the northern boundary, enabling a soft interface with the adjoining residential property.
- A landscape response along the Warnbro Sound Avenue frontage to enhance the development's relationship with this regional road.
- Creating an attractive and viable landscape entry feature to Aurea Boulevard to create a sense of arrival.

The landscaping arrangements are further explained and depicted in the landscape plan prepared by Plan E, provided at **Appendix 4**.

5.4.5 MATTERS TO BE GIVEN DUE REGARD

Clause 67(2) of the Deemed Provisions provides a list of matters which require due regard when considering a development application. **Table 3** below provides an assessment against the relevant matters.

Table 3: matters to be given due regard	
Matter to be given due regard	Comment
(a) the aims and provisions of this Scheme and any other local planning scheme operating within the Scheme area	The content of this report addresses LPS2, and demonstrates the proposal is consistent with its aims and intent.
(c) any approved State planning policy	This application addresses SPP4.2 and SPP7.0.
(g) any local planning policy for the Scheme area	The subsequent sections of this report address the City's local planning policy framework.
(h) any structure plan or local development plan that relates to the development	The subsequent sections of this report address the applicable structure plan and local development plan.
(m) the compatibility of the development with its setting, including — (i) the compatibility of the development with the desired future character of its setting; and (ii) the relationship of the development to development on adjoining land or on other land in the locality including, but not limited to, the likely effect of the height, bulk, scale, orientation and appearance of the development;	<ul style="list-style-type: none"> • The development site and surrounding land is zoned Commercial under LPS2. The six lots zoned Commercial are intended to form a neighbourhood centre precinct as outlined in the respective structure plan. • The mix of land uses is appropriate and provides for the daily to weekly household needs of residents, through the provision of a supermarket, liquor, fast food, and fuel. • The key emphasis of the neighbourhood centre precinct is the establishment of a



'main street' along Thundelarra Drive, intended to comprise shops opening directly onto the street, alfresco dining, continuous awnings and onstreet parking. The development proposal achieves this through the street edge setback of the supermarket, specialty shops, and provision of an arcade as a quality urban space. A high quality of design which creates pedestrian-level engagement is delivered through the layout and built form approach of the development.

- The established context of Aurea Boulevard is principally vehicle focused and not conducive to built form or meaningful activation, and is more suitable for access and car-based activity. This is due to the existence of three traffic lanes with a solid central median for most of the road frontage (as well as the proximity to a major signalised intersection). The provision of an access point, large landscape feature and service station along this frontage reasonably addresses its characteristics and maintains consistency with recently completed development at its southern side.
- Warnbro Sound Avenue is a regional road carrying high traffic volumes, and is an appropriate frontage for exposure-based commercial development which would draw patrons into the centre via Aurea Boulevard. With this in mind, the architecturally designed liquor store and fast food outlets with landscape buffers form a suitable response to this road.

In consideration of the above, the arrangement and execution of the proposed development addresses the character of its setting.

In terms of the scale, height, orientation and appearance of the development, each of the proposed buildings is designed through careful consideration of their surroundings with architectural treatments, materials, finishes reflective of the coastal character of the locality.

Buildings achieve the minimum scale encouraged by the local planning framework and present to the public realm with the appropriate level of articulation/treatment. The arrangement of buildings along the periphery of the site with car parking in the centre significantly screens views of the car park from the public realm.

The development is entirely compatible with its surroundings.

(n) the amenity of the locality including the following

(i) environmental impacts of the development;

The proposed development will create positive environmental impacts, noting the site is currently in a derelict condition and contains

<p>(ii) the character of the locality; (iii) social impacts of the development;</p>	<p>unfinished structures/infrastructure commenced but never completed in 2017. This would be replaced with a high quality neighbourhood centre development.</p> <p>As explained in earlier sections of this report, the character of the locality will be enhanced as a result of this development proposal. The neighbourhood centre features a suitable mix of land uses, and is designed in a manner which appropriately responds to its surroundings.</p> <p>The development will establish a vibrant neighbourhood centre on the site, which will deliver facilities catering for the daily and weekly needs of local residents. The uses will create site activity during all periods of the day and will create significant jobs for the surrounding community. Positive social impacts will result from the development.</p>
<p>(p) whether adequate provision has been made for the landscaping of the land to which the application relates and whether any trees or other vegetation on the land should be preserved</p>	<p>A landscape plan is provided with the DA package which demonstrates suitable landscaping arrangements throughout the site.</p>
<p>(s) the adequacy of (i) the proposed means of access to and egress from the site; and (ii) arrangements for the loading, unloading, manoeuvring and parking of vehicles;</p>	<p>A TIA has been produced in support of the proposal which demonstrates the appropriateness and adequacy of proposed access arrangements.</p> <p>The TIA also includes swept path plans demonstrating the acceptable movements of waste collection vehicles, which can enter and exit the car park in forward gear.</p>
<p>(t) the amount of traffic likely to be generated by the development, particularly in relation to the capacity of the road system in the locality and the probable effect on traffic flow and safety</p>	<p>A TIA has been produced in support of the proposal which demonstrates the traffic generation of the neighbourhood centre is entirely capable of being accommodated by the surrounding road network. This includes peak hour traffic generation at the site crossovers and nearby intersections.</p>
<p>(w) the history of the site where the development is to be located</p>	<p>The site was formerly approved for a 'village centre' development, which included a supermarket of 1,050sqm, small retail tenancies totalling 1,115sqm, a standalone liquor store of 280sqm, and a medical facility with 6 consulting rooms. The development was commenced in 2017 but never completed, and the unfinished structures and other infrastructure have remained on the site since this time.</p>
<p>(x) the impact of the development on the community as a whole notwithstanding the impact of the development on particular individuals</p>	<p>The establishment of a vibrant neighbourhood centre on the site which includes a supermarket, specialty stores, liquor store, fast food facilities and local service station will cater for the daily and weekly needs of local residents. The development along Thundelarra Drive is arranged and designed in a manner which creates social cohesion and pedestrian interactivity, due to its main street typology and central arcade.</p>

5.4.6 DEVELOPMENT CONTRIBUTION AREA NO.2 (DCA2)

The development site is located within DCA2 of LPS2. Pursuant to the provisions of DCA2, contributions are levied based on the number of 'dwelling units'. As the development proposal is for non-residential land uses, no 'dwelling units' will be created and hence no contribution is triggered.

5.5 GOLDEN BAY STRUCTURE PLAN

The Golden Bay structure plan was initially endorsed in 2012 and most recently amended in 2021. The structure plan is intended to *guide* development outcomes.

The structure plan contemplated a commercial zoning for the development site and five other lots around it, to form a 'neighbourhood centre precinct'. This zoning is reflected as part of LPS2.

Part Two of the structure plan outlines potential outcomes for the neighbourhood centre, informed by a retail analysis undertaken in 2011. The key elements included:

- The establishment of a local 'main street' based neighbourhood centre.
- Approximately 3,500sqm of retail NLA, supported by community uses.
- A 'medium' sized supermarket of 1,800qm-2,000sqm plus 'special shops' equating to 1,100sqm-1,300sqm.
- Retail component located at the western side of Warnbro Sound Avenue.

The proposed development is broadly consistent with the structure plan, noting it establishes a 'retail core' comprised of a supermarket with a range of supporting tenancies offering local residents daily and weekly household shopping services. The total NLA provided by the development equates to 2,495sqm.

The positioning of the supermarket, specialty shops, service station retail building and local arcade along Thundelarra Drive with interactive building form (ie pedestrian level windows, entries to the arcade, awnings, etc) establishes the 'main street' outcomes envisaged by the structure plan.

The arcade is a particularly important element, as it creates a communal space on the site for alfresco dining, connection between the supermarket / speciality shops, and facilitates a strong pedestrian link through the site which connects to a bus stop on Warnbro Sound Avenue as well as the footpath network to the surrounding area. Foot traffic is funnelled through the arcade to create pedestrian exposure to the speciality tenancies. The main entry to the supermarket is deliberately positioned at the building's corner facing Thundelarra Drive as this ensures activation is achieved should patrons enter from the street or the car park.

The growth, development, and evolution of Warnbro Sound Avenue and Aurea Boulevard in the vicinity of the site have informed the development typology and response to these frontages, which are clearly car-based and represent important opportunities to enhance accessibility and receive exposure to a regional road with high traffic volumes (in turn also securing the viability of the project).



5.6 GOLDEN BAY LOCAL DEVELOPMENT PLAN (LDP)

The Golden Bay LDP is currently at version 8, most recently amended and endorsed in 2021.

The LDP contemplates a number of development and design standards for the development site, intended to *guide* development outcomes for the neighbourhood centre.

In accordance with Clause 56(1) of the Deemed Provisions, a decision maker “*must have due regard to, but is not bound by, the local development plan which deciding the application*”.

The objectives outlined in Section 1 of the LDP are extracted below:

1. Objectives

The objective of this DAP are to:

- a) Establish a ‘Main Street’ based Neighbourhood Activity Centre of a scale that is appropriate to its role as a focal point of a residential community and its role in the retail hierarchy of the region.
- b) Provide a context for higher-density residential development that capitalises on proximity to local services.

The proposed development establishes a main street along Thundelarra Drive, achieved through the positioning of the supermarket, piazza/arcade, speciality tenancies, and service station building facing the street with typical urban design features including:

- Street-edge setbacks addressing the street with architectural design features.
- Full height windows at pedestrian scale which create mutual views and interactivity.
- Entrances to the street edge, connectivity within the arcade, and alfresco seating to strengthen its role as a quality urban space.
- The use of awnings, trees in raised planters, and clearly defined pedestrian pathways to establish a legible and comfortable pedestrian environment.

The LDP map envisages a range of active frontages, architectural/landmark responses to corners, vehicle access, and a piazza space. The layout/configuration of the development proposal is broadly consistent with the LDP, though some minor/reasonable deviations are proposed which are a logical consequence of:

- The character/function of Warnbro Sound Avenue and Aurea Boulevard in the vicinity of the site, including the nature of development in the immediate area.
- Economic viability considerations associated with land use typology and restrictive building envelope constraints set out by the LDP.
- Optimal design outcomes striking an appropriate balance between context, functionality, and the factors outlined above.

Table 4 below provides an assessment against the provisions of the LDP.



Table 4: local development plan assessment

2. Standards	
a) Structure	
i. The road annotated as 'main street' must be the main street for the neighbourhood centre.	The development proposal respects the provision of a 'main street' along Thundelarra Drive, noting this is where the supermarket, specialty stores, arcade, and convenience building are provided with a nil setback and interactive design features.
b) Street interface	
i. All buildings must provide passive surveillance of adjacent street reserves by means of active or habitable frontage.	This provision is achieved through: <ul style="list-style-type: none"> • The supermarket, arcade, speciality stores, and convenience retail building providing active frontage to Thundelarra Drive with windows and openings. • The liquor store's western façade and drive through containing openings directly facing Wyloo Lane. • The service station's building and refuelling area providing clear and open views to Aurea Boulevard, as well as the 260sqm fast food's drive-through pick up area which operates 24 hours.
ii. Where active frontage is required and/or a Orn street setback has been provided, the frontage must incorporate a canopy(s) with continuous coverage to a minimum depth of 2.5m or to within 600mm of the back of the adjacent kerb where the verge is too narrow to accommodate a 2.5m deep canopy, and must extend across the entire street frontage of the building.	A 2.5m wide canopy is provided along all buildings with nil setback to Thundelarra Drive (the main street). The canopy extends into the piazza / arcade space to ensure shelter and comfort is provided for pedestrians and patrons.
iii. The street setback for multiple dwellings may be reduced to Orn in the case of mixed-use development, and also for residential building elements that provide architectural interest and where a reduction in the minimum setback (stated in the OAP) does not compromise the amenity of residents (for example, for vertical circulation elements, lobbies, and upper levels).	Not applicable.
iv. Delivery, loading and storage areas must be located and screened to minimise the visual impact on the public domain.	This has been achieved as follows: <ul style="list-style-type: none"> • Supermarket: siting the loading area at the eastern side of the building to face the car park, and providing an architecturally treated screen wall along its northern side. • Service station: internalise the service area to face eastward into the forecourt, with a small loading area not evident from the street. • Fast foods: siting the service yards at the northern side of both buildings, ensuring views are screened from most angles by both buildings. • Liquor: back of house area is sited at the eastern side of the shop, comprising architecturally treated walls and screen landscape planting along the northern and eastern boundaries to prevent visibility from the public realm.



	The development effectively and efficiently screens service areas, whilst ensuring they are accessible from within the car park.
v. Street elevations must be designed to create visual interest through building form, articulation of walls and openings, architectural features, texture and colour, with particular emphasis given to the ground floor level.	<p>The street elevations of the supermarket, specialty shops, and service station building achieve these requirements with:</p> <ul style="list-style-type: none"> • Pedestrian level windows and openings • Articulation and alternating textures • Colour tones and materials reflective of the coastal context of the site • Feature roof form for the service station and curved building returns for the supermarket and specialty stores. <p>The street elevations of the fast food sites achieve similar outcomes, paying particular attention to varied roof heights, alternating colours/materials, and the use of structural feature screens along drive-through spaces.</p> <p>The integration of landscaping and tree planting is a key element of the built form response and works to enhance the creation of visual interest.</p>
vi. Non-active portions of walls must be articulated by means of form, colour and texture to provide visual interest.	This is achieved on all facades facing a street, as evident on the elevations.
vii. Garage doors and supporting structures for residential development must not exceed 50% of the frontage at the front setback line from the Primary Street. This can be increased to 60% for two-storey dwellings in accordance with clause 5.2.2 of the R-Codes.	Not applicable.
c) Landscape	
i. The landscape material used for the footpath must be continued across driveways and the entrances to Rights of Way to maintain visual continuity of the pedestrian network and aid pedestrian legibility.	Noted.
ii. Street trees must be provided at a minimum rate of 1 tree per 14m on both sides of the streets within the DAP area.	A substantial number of street trees are proposed along all frontage roads of the development, achieving this requirement.
iii. Shade trees must be provided to all publically accessible and open car parks not otherwise provided with shade structures at a minimum rate of 1 tree per 8 car bays.	The development includes 105 marked bays, requiring 13 trees. The landscape plan significantly exceeds this requirement throughout the car park.
iv. The special vegetation screens' identified on the DAP must consist of trees and an under-storey of low-level shrubs, rather than mid-level shrubs, to maintain sightlines for pedestrians, and must be of a minimum of 3m in width.	A landscape strip up to 3.9m wide is provided along Warnbro Sound Avenue and a landscape strip up to 2.1m wide is provided along the northern boundary of the liquor store. The landscape concept demonstrates appropriate planting arrangements within these areas, ensuring a suitable response to the street and adjoining property.

d) Robustness	
i) The ground floor of all buildings in the Commercial area must be designed with a minimum floor-to-floor height of 3.2m to enable commercial uses even if used for interim residential use.	Noted.
ii) The ground level of all buildings in the Commercial area must be designed for disabled access regardless of the initial use.	Noted.
e) Fencing	
i. Any fencing to the primary or secondary street(s) frontage must be restricted to residential uses only. ii. Where street frontage fencing is employed, it must be no more than 1.8m high and must be at least 50% visually permeable from 0.9m above the ground level of the adjacent street with solid portions of fencing consisting of masonry construction. iii. Colorbond fencing is not permitted within any street setback area.	No street fencing is proposed.
f) On-street parking	
i. For the purpose of calculating parking provision, any on-street parking bays adjacent to a lot on the same side of the road may be included in the calculation of visitor parking provision for that lot.	Noted.
g) Open space	
<i>Not applicable</i>	
3. Design principles for the retail core	
a) Tenancies must present their main entrance to the main street or the community piazza space if frontage to either is provided.	This requirement is achieved as follows: <ul style="list-style-type: none"> • The supermarket's main entrance is provided at the corner facing Thundelarra Drive. • The specialty tenancies' entrances face the piazza/arcade and the corner fronting Thundelarra Drive. • The service station retail building includes an entrance facing Thundelarra Drive.
b) Tenancies must present active and visually permeable frontages to the main street or the community piazza space and any connecting mall between the main car park and the street.	This requirement is achieved, noting the street / arcade frontages of the supermarket, specialty tenancies, and service station retail building are all visually permeable with significant transparent windows and entrances.
c) Pedestrian movement from the main car park to the supermarket must be directed past the supporting tenancies to provide them with exposure and economic support.	This requirement is achieved, noting the entrance to the supermarket is provided at the corner facing Thundelarra Drive. This results in pedestrian movement from the car park passing through the arcade which creates foot traffic for the specialty tenancies.

d) Any public door between the supermarket and the main car park must be an exit only, to enable convenient trolley access and avoid trolleys in the main street.	No public door is provided between the supermarket and the car park.
e) Bin storage and other service areas must be discretely located to enable direct access (or via a service corridor) to a vehicle collection point.	The service area for the supermarket faces the car park and is appropriately screened such that it is not evident to the public realm.
f) The community piazza area must be designed to provide for greenery, shade, and casual seating.	The arcade/piazza includes greenery through trees in raised planters, shade through awnings, and casual seating within dedicated areas to establish a quality urban space.

4. Minimum building heights

Commercial zoning: Sites developed exclusively for residential uses must be a minimum of two storeys in height to achieve a village scale, and must comply with the minimum ground floor floor-to-floor heights pursuant to Provision 2(d). Sites developed exclusively for commercial uses are permitted as single storey but with a minimum parapet height of 5.5m or a minimum eaves height of 4.5m where a pitched roof is utilised.	All of the proposed buildings are designed at the required scale, with parapet heights generally at 5.5m or higher. The buildings include varied roof heights which accentuate the higher components as architectural features to create visual interest, and to assist with achieving suitable response to street frontages and corner locations within the site.
---	--

5.7 LPP 3.1.2 LOCAL COMMERCIAL STRATEGY

The City's LCS sets out the retail hierarchy of the municipality, allocating activity centres and outlining the strategic planning principles in respect of the ongoing expansion and establishment of the centres.

Golden Bay forms part of the 'south coastal' precinct as outlined within the LCS. In accordance with Section 1.8 of the LCS, the key objectives relevant to this development proposal are extracted below:

- *Promote centre locations which offer a level of accessibility commensurate with the size and function of the centre.*
- *Promote centres as the foci for community activity and public transport.*
- *Prevent ad hoc ribbon development along major roads particularly Read Street / Warnbro Sound Avenue.*
- *Encourage the provision of ancillary convenience uses co-located at suburban shopping centres, retailing and other, that are operated independently and separately of the core retailing within the shopping centres and frequently operate extended trading hours. Such uses include fast food outlets, restaurants, video rental, chemist shops within medical centres, convenience shops attached to service stations and the like.*

The site forms part of the Golden Bay 'neighbourhood centre' which carries a recommended retail floorspace allocation of 3,540sqm under the LCS.



Section 2.3 of the LCS deals with neighbourhood and local shopping centres, setting out broad criteria for the siting and composition of such facilities.

The development site is identified as the 'core' of the neighbourhood centre, noting it is positioned centrally within the precinct and the most readily accessible by both car and foot. In this regard:

- The site is located at the western side of Warnbro Sound Avenue, connecting it to the emerging Golden Bay estate and the established parts of Golden Bay which are interconnected by a pedestrian footpath network. A connection does exist to the eastern side of Warnbro Sound Avenue, however given this is a regional road and the connection is through a major signalised intersection, the quality of the walkable connection is diminished and not convenient.
- The site benefits from corner frontage to the full movement Warnbro Sound Avenue / Aurea Boulevard signalised intersection. Warnbro Sound Avenue carries almost 10,000 daily vehicles and affords significant exposure to the development site.

With the above factors in mind, the neighbourhood centre development is configured and designed in response to its context, executed in a manner which has regard to the overarching principles of the LCS.

The uses are proposed on land appropriately zoned for commercial purposes under LPS2, and are distributed/designed such that Thundelarra Drive is established as the community focal point whilst the area fronting Warnbro Sound Avenue provides ancillary convenience uses which benefit from exposure to a regional/busy road whilst forming part of the core of the neighbourhood centre.

In terms of retail floorspace usage, the following is noted:

- A total retail floorspace of 3,540sqm is allocated to the Golden Bay neighbourhood centre, which is distributed between six lots zoned Commercial under LPS2.
- The development site, being the core of the neighbourhood centre, comprises 2,495sqm retail floor area including the supermarket, liquor, speciality tenancies, service station convenience building, and fast food premises. This represents 70% of the total floorspace allocation of the neighbourhood centre.
- The established development south of the development site includes a total of 490sqm commercial floor area associated with a convenience store and separate commercial building.
- 555sqm of retail floorspace remains for the two undeveloped lots zoned for commercial purposes (ie Lot 636 and Lot 9036).

The development proposal ensures the retail floorspace capacity of the neighbourhood centre is not fully exhausted, and will preserve development options for the two remaining commercial sites. In turn, this increases the likelihood of the vacant sites being considered for development in the foreseeable future.



5.8 LPP 3.3.1 CONTROL OF ADVERTISEMENTS

Proposals involving external signage are to be assessed against the City's Planning Policy 3.3.1.

The proposed neighbourhood centre development includes the following signage:

- Signage panels integrated into the facades of the supermarket, fast food facilities, liquor store, and service station. The signs are designed in a manner consistent with the buildings on which they're located and are signs ordinarily found as part of commercial development.
- Two 6m high freestanding 'neighbourhood centre' signs along Warnbro Sound Avenue, which will ensure the businesses forming part of the overall neighbourhood centre are appropriately identifiable to passing traffic.
- A 6m high freestanding 'neighbourhood centre' sign along Aurea Boulevard, which will ensure the businesses forming part of the overall neighbourhood centre are appropriately identifiable to the local area.
- A 6m high freestanding service station sign with digital priceboard along Aurea Boulevard, which will ensure the services offered by the service station and including the price of fuel is appropriately displayed to passing vehicles.
- A 3m high digital priceboard for the service station, which is integrated into the Thundelarra Drive façade of the retail building and allows the price of fuel to be displayed to the local area.
- A 4.8m high wall-mounted pylon sign integrated into the supermarket building, which would contain 'neighbourhood centre' signage fronting Thundelarra Drive. The sign is innovatively integrated into the building.

In accordance with Section 4.3.1 of the policy, a 'signage strategy' is required to be submitted for approval. The information provided on the plans is considered to constitute a 'signage strategy'.

Wall signs

With regard to the wall signs, the following is noted:

- No signage is included for the two fast food facilities, and will be subject to a separate application. Notwithstanding this, provision is made for these tenancies on the main centre pylon signs as part of this application.
- The extent of wall signs for the service station is typical of this type of land use, with individual signs provided above the entrances and on the canopy.
- The signs proposed for the specialty tenancies is characteristic of what would typically be seen in an 'arcade' setting, comprised of signs above entrances and small blade signs visible by foot traffic.
- Signs for the supermarket are relatively minimal, including supermarket tenant signage facing Thundelarra Drive and the car park, as a sign above the service area to indicate loading.



- The liquor store features the usual wall-mounted signage at the upper section of only two facades, facing Wyloo Lane and Warnbro Sound Avenue. Drive through signage is integrated into the canopy for directional purposes.

It is evident from the elevations and signage strategy that the wall-mounted signage does not dominate any of the building facades and is entirely consistent with what would be expected as part of a multi-use neighbourhood centre type development.

Pylon signs

With regard to the pylon signs, the following is noted:

- None of the proposed freestanding signs exceed 6m in height.
- The Warnbro Sound Avenue frontage of the development exceeds 120m in length, and is a regional road with high traffic volumes. It is appropriate for this frontage to contain two freestanding signs.
- The Aurea Boulevard frontage is almost 100m in length and serves an important connector function for the local area. It is appropriate for this frontage to contain two freestanding signs, and in particular, a sign which displays the price of fuel for the service station. The character of this road is clearly car-based and commercial in nature.
- None of the proposed signs project over a street, walkway or public area.
- None of the proposed signs exceed 3.5m of width.
- Along Thundelarra Drive, freestanding signs are eliminated by innovatively integrating these types of signs into the building façades. This preserves streetscape character and contributes toward a 'main street' feel.
- The extent of freestanding signs ensures all of the tenancies / businesses forming part of the neighbourhood centre have equitable advertisement space.

The number, extent, size and location of the proposed freestanding signs is acceptable and warrants the City's support.

5.9 LPP 3.3.9 FAST FOOD OUTLETS

The City's Planning Policy 3.3.9 applies to the development of fast food outlets throughout the municipality.

The development proposal is consistent with the City's fast food outlets policy for the following reasons:

- Section 4.1 of the policy clarifies that the preferred locations for fast food outlets are within "*approved Neighbourhood and District Town Centre zones and within the City Centre Zones*".
- The fast food facilities are sited away from potentially sensitive residential properties and away from Thundelarra Drive (the 'main street'), and positioned adjacent to Warnbro Sound Avenue (a regional road with high traffic volumes).

The fast food facilities are appropriately separated from other uses on the site with kerbing and promote coordinated internal traffic flows.

- Landscape planting is proposed along the street frontages adjacent to the fast food facilities and the drive-through areas of both facilities comprise structural feature screening which enhances architectural design quality.
- The drive-through areas of both facilities exceed the minimum 10-car capacity outlined by the policy. In relation to parking provision, a detailed parking analysis is provided in the supporting TIA which demonstrates an overall adequate amount of car spaces for the development.

The development proposal appropriately addresses the City's fast food outlets policy and warrants support.

5.10 LPP 3.3.14 BICYCLE PARKING AND END OF TRIP FACILITIES

The City's Planning Policy 3.3.14 applies to all planning applications throughout the municipality.

The policy contains rates for the provision of 'short term' and 'long term' bicycle parking. For the sake of simplicity, the rates outlined for 'neighbourhood centre' shop have been applied to the entire development.

Based on a total gross leasable area of 2,495sqm across all of the proposed land uses, bicycle parking provision requirements are:

Short term: 8 spaces

Long term: 3 spaces

The development provides 15 bike racks. The total bicycle parking provision therefore exceeds the City's requirements.

End of trip facilities are only required following the first five long-term spaces, hence are not triggered by this development proposal.

5.11 LPP 3.3.25 PERCENT FOR ART

The City's percent for art policy applies to development proposals with an estimated cost of over \$5 million, and which is not an 'exempted' development as outlined under Section 3 of the policy.

The proposed Golden Bay neighbourhood centre development will require a public art contribution of \$110,000. The proponent will determine whether this contribution is paid as cash-in-lieu or delivered onsite in the later stages of the project.

If the public art is to be delivered onsite, this will most likely occur within the landscape feature area fronting Aurea Boulevard.



5.12 LPP 3.4.3 URBAN WATER MANAGEMENT

Planning Policy 3.4.3 applies to development proposals that facilitate commercial development and promotes water sensitive urban design outcomes.

The Golden Bay structure plan applies to the development site and the local area. Under Section 8 of the structure plan, an Urban Water Management Plan (**UWMP**) would be required at subdivision stage. The development site was created in 2016 in accordance with a subdivision approval, and a UWMP was established over the local area.

In accordance with Section 4.1.4 of the policy, the City may impose conditions of planning approval on a planning application requiring a stormwater management plan (**SMP**) to be prepared which demonstrates consistency with an approved UWMP.

As the general drainage management arrangements for the site and local area have been determined through a UWMP, it is appropriate for an SMP to be provided at building permit stage in accordance with Planning Policy 3.4.3.

5.13 EPA GUIDANCE STATEMENT NO. 3

The EPA's guidance statement for 'separation distances between industrial and sensitive land uses' was introduced in 2005 and provides guidance on the use of generic separation distances (buffers) between certain developments and 'sensitive' land uses.

The separation distances set out by EPA Guidance Statement No.3 are not absolute, and lesser distances are commonly accepted where it is demonstrated through justification that the potential impacts associated with the proposed development can be suitably managed.

For service stations, the potential impacts listed by the document are *gaseous, noise, odour and risk*. The subject development seeks approval for a 24 hour service station facility, which involves a suggested buffer distance based on 24 hour operations proposed.

In considering separation distances, it is important to note that:

- The modern service station is designed to a high standard and employs best practice design features relating to the storage and handling of fuel, stormwater treatment, external lighting, and noise mitigation to reduce site externalities.
- The storage and handling of fuel is a highly regulated activity, separate to the development approvals process. A site cannot store or sell fuel without first obtaining a licence from the Department of Mines, Industry Regulation and Safety (**DMIRS**) which requires strict criteria to be met and assessed through various detailed scientific assessments as part of the process regulated under the *Dangerous Goods Safety Act 2005*.



Table 5 below provides a response to the potential impacts listed by the guidance statement, demonstrating that a lesser separation distance is warranted and acceptable.

Table 5: response to EPA separation guidelines
Gaseous/Odour
<p>An emissions impact assessment was prepared to consider airborne pollutants associated with the proposed 24 hour service station against established standards. The assessment is provided at Appendix 8.</p> <p>The assessment conservatively considers potential emissions from the service station, including potential cumulative impacts due to the existence of a service station on the opposite side of Aurea Boulevard.</p> <p>The assessment demonstrates that the relevant airborne pollutants all fall <u>below</u> guideline exposure standards, subject to the proposed service station employing both Stage 1 and Stage 2 vapour recovery systems.</p> <p>In addition to the above, the dangerous goods licensing process addresses impacts associated with vapour. The fuel bowsers are required to achieve prescribed setbacks under the Dangerous Goods licensing requirements and a site-specific assessment is undertaken under that process to ensure the facility's design and layout meets regulatory requirements before fuel can be stored and sold from the site. The following considerations are assessed as part of the dangerous goods licensing process:</p> <ul style="list-style-type: none"> • Spill and leak containment • Segregation of dangerous goods • Control of ignition sources in hazardous areas • Control of hazardous substances that includes any gas, vapour, mist, fume or dust • Design, construction, maintenance and location of storage or handling systems, including location and separation distances so that as far as reasonably practicable they can be operated with minimal risk to people, property and the environment • Underground storage or handling systems for petroleum products designed, installed, operated and maintained so they don't leak
Noise
<p>The development has been assessed against the <i>Environmental Protection (Noise) Regulations 1997</i> by way of an environmental noise assessment produced by Lloyd George Acoustics. The assessment demonstrates the proposed development will generate acceptable and compliant noise levels over a 24 hour period.</p>
Risk
<p>The facility must obtain a dangerous goods licence under the <i>Dangerous Goods Safety Act 2004</i> before any fuel can be stored, handled or sold from the site. This process is regulated under separate legislation, and a licence is obtained after the development approvals process by a specialised consultant. The site has been designed to ensure it can obtain a dangerous goods licence.</p> <p>A risk assessment is required as part of an application for a dangerous goods licence. The risk assessment:</p> <ul style="list-style-type: none"> • Identifies all hazards relating to the dangerous good proposed to be stored at the site; • For each hazard, assesses the probability of the hazard causing a dangerous goods incident, and assesses the consequences of the incident to people, property and the environment; and • Identifies any required risk control measures. <p>If a coherent and acceptable risk assessment is not prepared, then a dangerous goods licence will not be issued. Risk is therefore comprehensively addressed through the dangerous goods licensing process.</p>

6 CONCLUSION

This application for planning approval involves the establishment of a neighbourhood centre development at Lot 622 (2) Aurea Boulevard, Golden Bay.

The proposal will create a vibrant and well-designed neighbourhood level shopping centre for the local community and will substantially enhance the site's contribution to local amenity. The mix of uses includes a supermarket with speciality tenancies, liquor store / fast food outlets (with drive-through components, meeting the contemporary standard of convenience), and service station.

The configuration of the proposed development is consistent with the site's commercial zoning and addresses the local planning framework, including the Golden Bay structure plan, local development plan, and applicable local planning policies.

The development site has remained in a vacant and derelict state for some time, resulting from a former 'village centre' development which was commenced but never completed. The proposal will significantly improve local conditions for the community by addressing this situation.

The proposed neighbourhood centre respects the provision of a 'main street' to Thundelarra Drive, incorporating a piazza/arcade area which will be a quality urban space and secures its viability by including suitable exposure-based uses along the site's Warnbro Sound Avenue frontage in response to local contextual conditions.

An attractive and engaging landscape approach has been formulated by a suitably experienced landscape architect which enables a sensitive and attractive relationship to adjoining properties and the public realm.

The proposal is also supported by a range of expert inputs demonstrating its acceptability from a traffic, noise, and emissions point of view.

The development proposal will create a significant community benefit and is consistent with the principles of orderly and proper planning.

It is respectfully requested that the City of Rockingham support the proposed development and that the Metro Outer JDAP grant approval to the proposed development.



APPENDIX 1

CONCEPTUAL SKETCH PLAN

DEVELOPMENT
ASSESSMENT PANEL

APPROVED
12-Mar-2024



NOTE!

- AREAS TO BE CONFIRMED
- LAYOUT SUBJECT TO:
 - TPS ASSESSMENT
 - DA APPROVAL
 - SERVICE VEHICLE TURN PATHS

APPENDIX 2

CERTIFICATE OF TITLE AND DEPOSITED PLAN



WESTERN



AUSTRALIA

REGISTER NUMBER 622/DP408508	
DUPLICATE EDITION N/A	DATE DUPLICATE ISSUED N/A

RECORD OF CERTIFICATE OF TITLE
UNDER THE TRANSFER OF LAND ACT 1893

VOLUME **2898** FOLIO **430**

The person described in the first schedule is the registered proprietor of an estate in fee simple in the land described below subject to the reservations, conditions and depth limit contained in the original grant (if a grant issued) and to the limitations, interests, encumbrances and notifications shown in the second schedule.

BGRoberts
REGISTRAR OF TITLES



LAND DESCRIPTION:

LOT 622 ON DEPOSITED PLAN 408508

REGISTERED PROPRIETOR:
(FIRST SCHEDULE)

GOLDEN BAY VILLAGE PTY LTD OF 69 CHALLENGE BOULEVARD WANGARA WA 6065
(T N498728) REGISTERED 1/12/2016

LIMITATIONS, INTERESTS, ENCUMBRANCES AND NOTIFICATIONS:
(SECOND SCHEDULE)

1. *F714364 EASEMENT TO THE WATER AUTHORITY OF WESTERN AUSTRALIA FOR SEWERAGE AND WATER PURPOSES - SEE SKETCH ON DEPOSITED PLAN 408508. REGISTERED 28/10/1994.

Warning: A current search of the sketch of the land should be obtained where detail of position, dimensions or area of the lot is required.
* Any entries preceded by an asterisk may not appear on the current edition of the duplicate certificate of title.
Lot as described in the land description may be a lot or location.

-----END OF CERTIFICATE OF TITLE-----

STATEMENTS:

The statements set out below are not intended to be nor should they be relied on as substitutes for the relevant documents or for local government, legal, surveying or other professional advice.



SKETCH OF LAND: DP408508
PREVIOUS TITLE: 2884-845
PROPERTY STREET ADDRESS: 2 AUREA BVD, GOLDEN BAY.
LOCAL GOVERNMENT AUTHORITY: CITY OF ROCKINGHAM

- NOTE 1: DUPLICATE CERTIFICATE OF TITLE NOT ISSUED AS REQUESTED BY DEALING M834524
NOTE 2: N262655 DEPOSITED PLAN 407077 LODGED



VERSION	AMENDMENT	AUTHORISED BY	DATE
2	Move Padcount Site in Lot 622	D. Grogan	2/3/2016
3	Amendment to Road Widening in Lot 622	D. Grogan	4/4/2016

HELD BY LANDGATE IN DIGITAL FORMAT ONLY
FOR INTERESTS AND NOTIFICATIONS
SEE SHEET 3

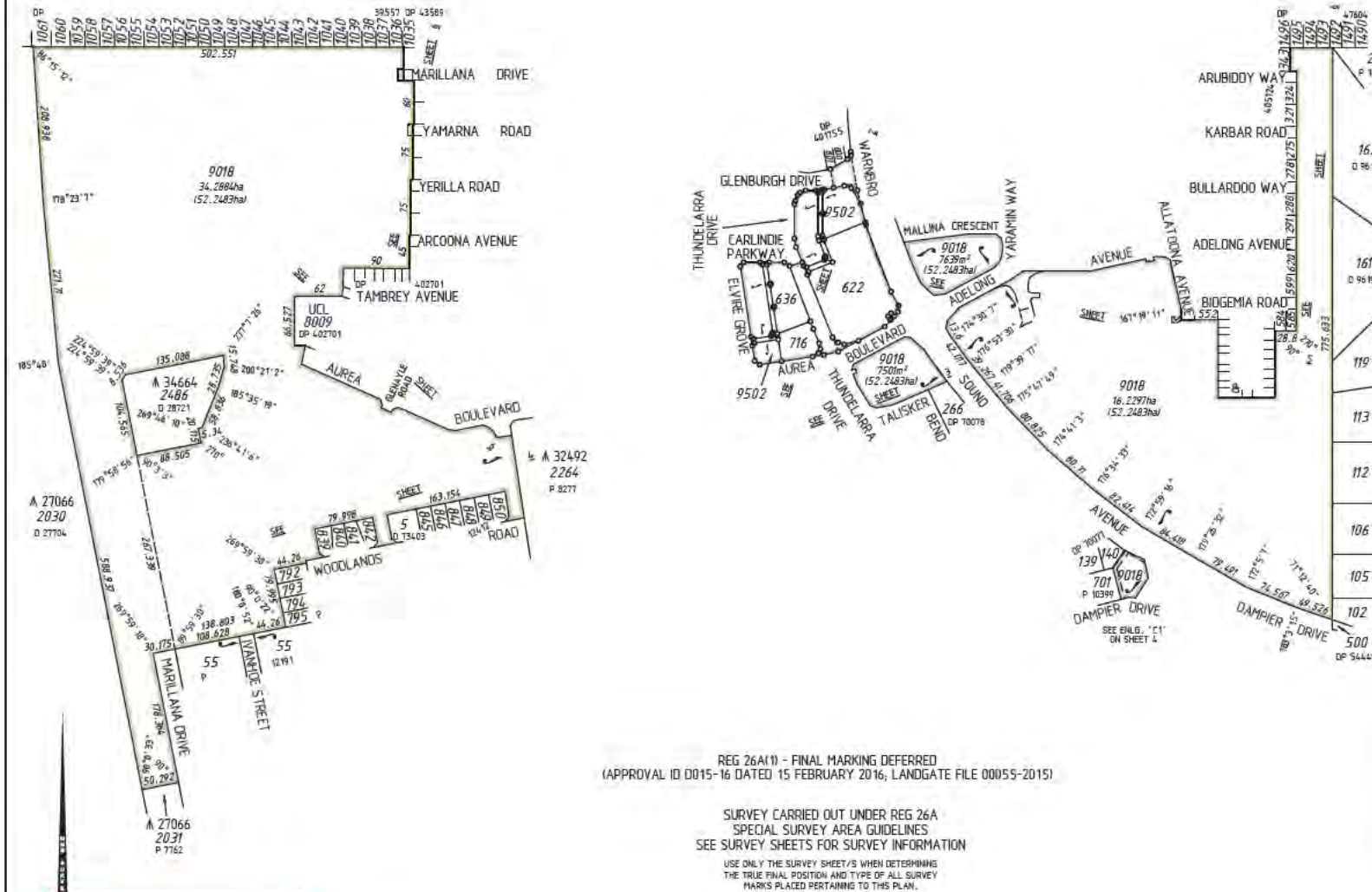

REG 26A(1) - FINAL MARKING DEFERRED
(APPROVAL ID D015-16 DATED 15 FEBRUARY 2016, LANDGATE FILE 00055-2015)

SURVEY CARRIED OUT UNDER REG 26A
SPECIAL SURVEY AREA GUIDELINES
SEE SURVEY SHEETS FOR SURVEY INFORMATION

USE ONLY THE SURVEY SHEET/S WHEN DETERMINING
THE TRUE FINAL POSITION AND TYPE OF ALL SURVEY
MARKS PLACED PERTAINING TO THIS PLAN.



TYPE	FREEHOLD	S.S.A.	YES
PURPOSE	SUBDIVISION		
PLAN OF	LOTS 622, 636, 716, 9018, 9502, ROAD WIDENING AND ROADS		
FORMER TENURE	LOT 9015 ON DP 406711 C.T.2864/845		
LOCAL AUTHORITY	CITY OF ROCKINGHAM		
LOCALITY	GOLDEN BAY		
D.O.L. FILE			
FIELD RECORD	1E072, 14645, 16956, 120380		
SURVEYOR'S CERTIFICATE - REG 54	Daniel T. GROGAN		
I hereby certify that this plan is accurate and is a correct representation of the - (a) survey, and/or (b) calculations from measurements recorded in the field records, (* delete if inapplicable) undertaken for the purposes of this plan and that it complies with the relevant written laws in relation to which it is lodged.			
LICENSED SURVEYOR	Daniel T Grogan 2016.04.04 14:20:28 +08'00'	DATE	
LOGGED			
22-Feb-16	\$821.00	18954360	
DATE	FEE PAID	ASSESS No.	
I.S.C.	18-Feb-16		
EXAMINED			
G.FONG		05-Apr-16	DATE
WESTERN AUSTRALIAN PLANNING COMMISSION FILE 145977, 152653			
Delegated under S. 16 P&D Act 2005 07-Apr-2016 DATE			
IN ORDER FOR DEALINGS			
SUBJECT TO	Sec's 150, 168(1)(2) & 168(3) P&D ACT		
FOR INSPECTOR OF PLANS AND SURVEYS			
		07-Apr-16	DATE
APPROVED REG26A (4)			
7.4.2016			
INSPECTOR OF PLANS AND SURVEYS			
S. 18 Licensed Surveyors Act 1909			
DEPOSITED PLAN			
408508			
SHEET 01 OF 06 SHEETS (PLUS SURVEY SHEETS) VERSION 3			

MCGILLION MOLAN GROUP
PO Box 1028, South Perth, W.A. 6146
Tel: (08) 4432 1339
Fax: (08) 4432 1300
Email: info@mngsurvey.com.au

MNG Pty Ltd ABN 5449210 - MAC1 - DP408508_C01

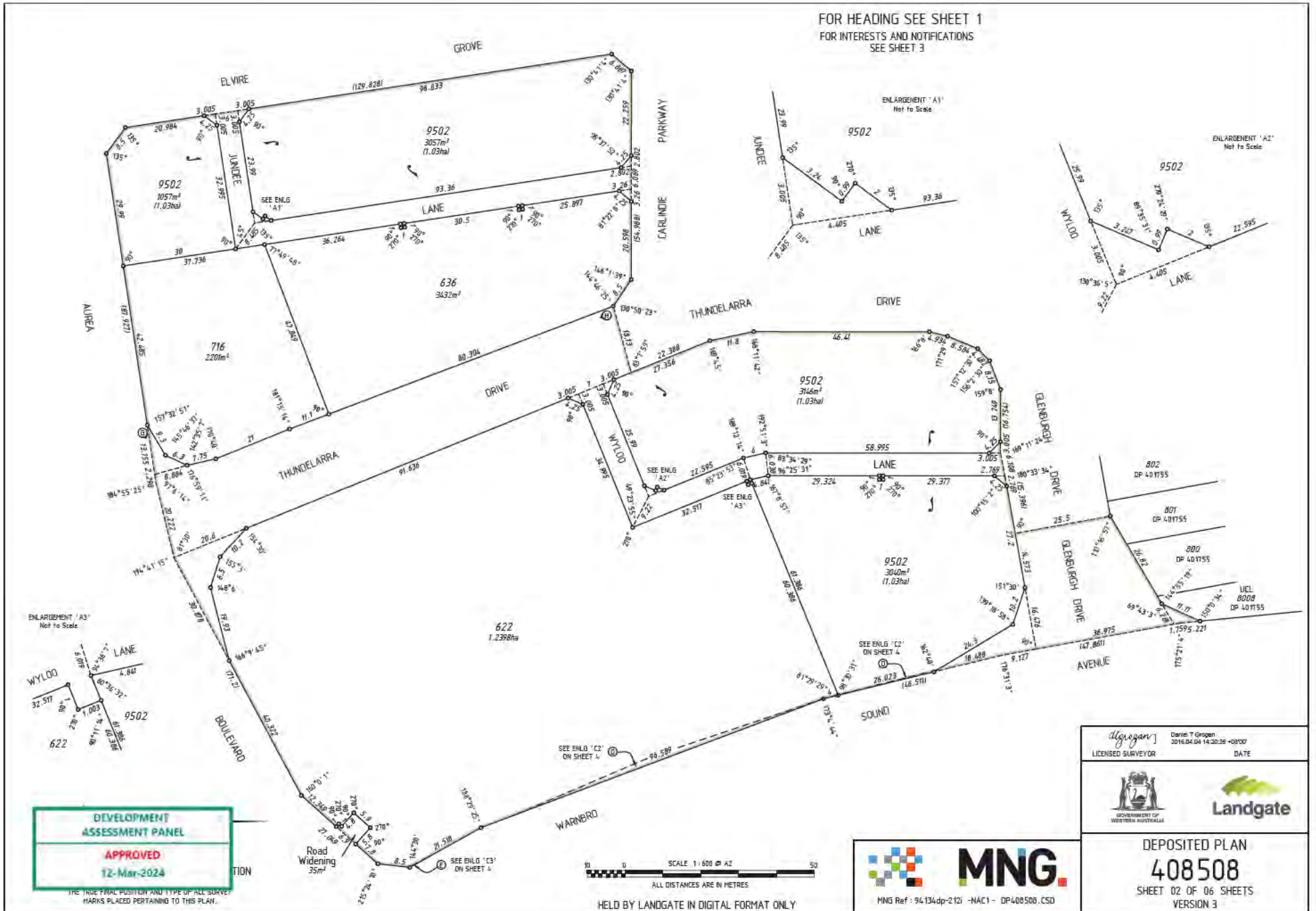

FOR HEADING SEE SHEET 1
FOR INTERESTS AND NOTIFICATIONS SEE SHEET 3

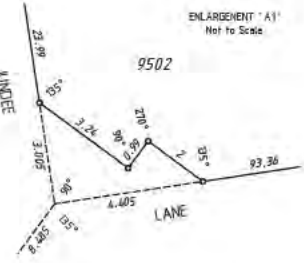

DEVELOPMENT ASSESSMENT PANEL
APPROVED
12-Mar-2024

THE TRUE FINAL POSITION AND TYPE OF ALL SURVEY MARKS PLACED PERTAINING TO THIS PLAN.

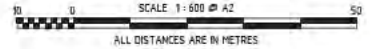

ALL DISTANCES ARE IN METRES
HELD BY LANDGATE IN DIGITAL FORMAT ONLY



Allegretto Darin T Groen
LICENSED SURVEYOR 3016.04.04 14:30:36 +0800
DATE



DEPOSITED PLAN
408508
SHEET 02 OF 06 SHEETS
VERSION 3

INTERESTS AND NOTIFICATIONS

SUBJECT	PURPOSE	STATUTORY REFERENCE	ORIGIN	LAND BURDENED	BENEFIT TO	COMMENTS
(D) (C)	EASEMENT		DOC F714364	LOT 9018	SEE DOC	AS REDEFINED ON DP72062
(D) (E)	EASEMENT		DOC F714364	LOT 622	SEE DOC	AS REDEFINED ON DP72062
(D)	EASEMENT		DOC F714364	LOT 9502	SEE DOC	AS REDEFINED ON DP72062
(A)	EASEMENT		DOC F848983	LOT 9018	SEE DOC	AS REDEFINED ON DP72062
(33a) 8	EASEMENT (Drainage)	SEC 167 OF THE P. & D. ACT REG 33 (a)	DP 77745	LOT 9018	CITY OF ROCKINGHAM	
(33a) 16	EASEMENT (Sewerage)	SEC 167 OF THE P. & D. ACT REG 33 (a)	DP 77745	LOT 9018	WATER CORPORATION	
(33b) 17	EASEMENT (Water Supply)	SEC 167 OF THE P. & D. ACT REG 33 (b)	DP 77745	LOT 9018	WATER CORPORATION	
(33c) 9	EASEMENT (Electricity Supply)	SEC 167 OF THE P. & D. ACT REG 33 (c)	DP 77745	LOT 9018	ELECTRICITY NETWORKS CORPORATION	
(33d) 9	EASEMENT (Gas Supply)	SEC 167 OF THE P. & D. ACT REG 33 (d)	DP 77745	LOT 9018	W. A. GAS NETWORKS PTY LTD	
(33c) 8	EASEMENT (Electricity Supply)	SEC 167 OF THE P. & D. ACT REG 33 (c)	DP 405 024	LOT 9018	ELECTRICITY NETWORKS CORPORATION	
(33c) 10 (33c) 11	EASEMENT (Electricity Supply)	SEC 167 OF THE P. & D. ACT REG 33 (c)	DP 406711	LOT 9018	ELECTRICITY NETWORKS CORPORATION	
(D) (K)	COVENANT	SEC 150 OF THE P & D ACT	THIS PLAN	LOTS 636 & 716	CITY OF ROCKINGHAM	NO VEHICLE ACCESS OR INGRESS IS PERMITTED FROM THIS LOT ONTO THUNDELLARRA DRIVE



ENLARGEMENT 'B1'
Not to Scale

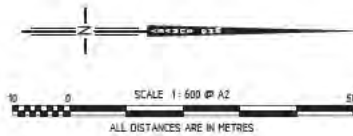

FOR HEADING SEE SHEET 1
 SURVEY CARRIED OUT UNDER REG 26A
 SPECIAL SURVEY AREA GUIDELINES
 SEE SURVEY SHEETS FOR SURVEY INFORMATION
 USE ONLY THE SURVEY SHEET/S WHEN DETERMINING
 THE TRUE FINAL POSITION AND TYPE OF ALL SURVEY
 MARKS PLACED PERTAINING TO THIS PLAN.

HELD BY LANDGATE IN DIGITAL FORMAT ONLY

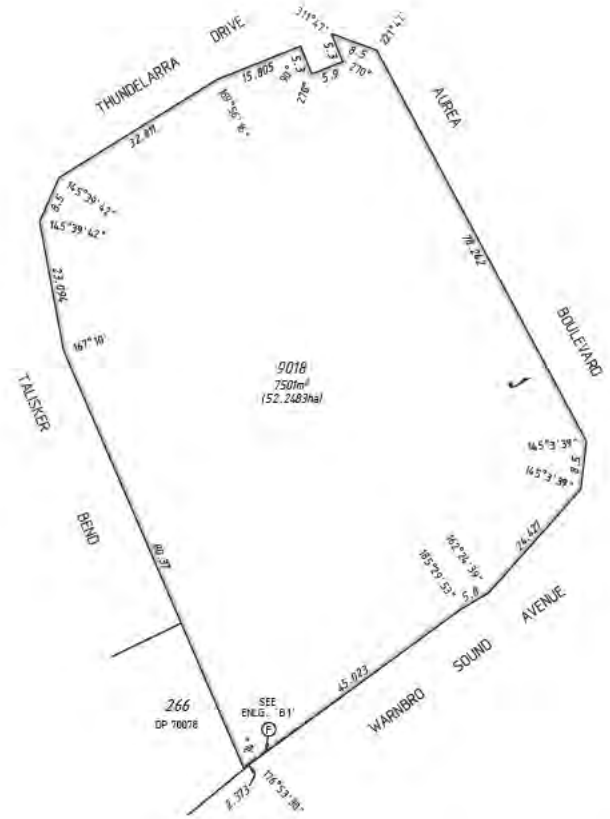

alleguan Daniel T Grogan
 LICENSED SURVEYOR 2016.04.04 14:20:44 +0800
 DATE



DEPOSITED PLAN
408508
 SHEET 03 OF 06 SHEETS
 VERSION 3



FOR HEADING SEE SHEET 1
FOR INTERESTS AND NOTIFICATIONS
SEE SHEET 3

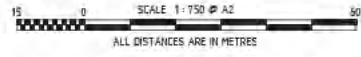
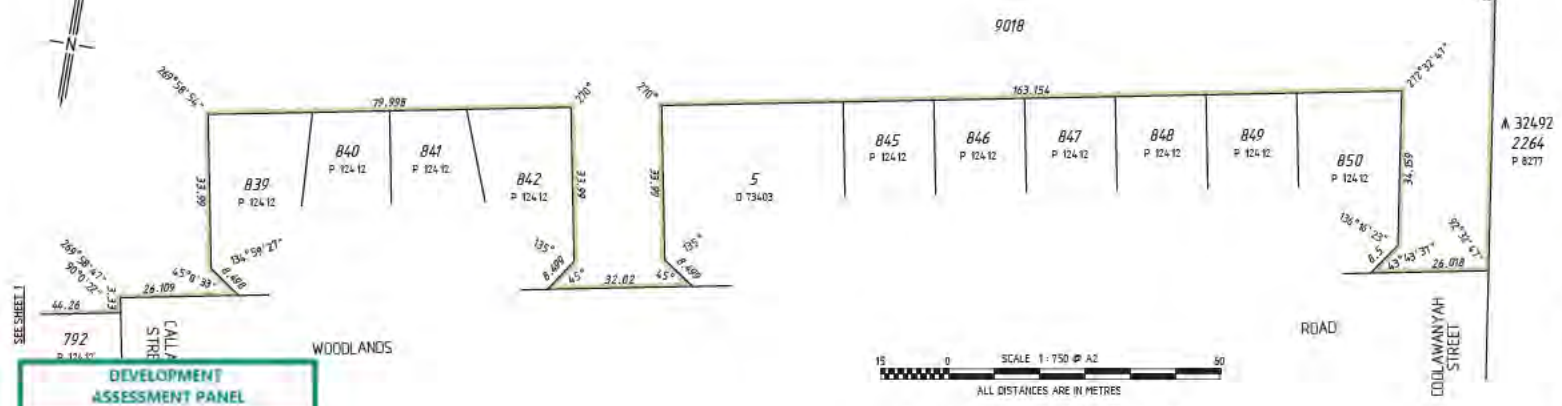

HELD BY LANDGATE IN DIGITAL FORMAT ONLY

SURVEY CARRIED OUT UNDER REG 26A
SPECIAL SURVEY AREA GUIDELINES
SEE SURVEY SHEETS FOR SURVEY INFORMATION

USE ONLY THE SURVEY SHEET/S WHEN DETERMINING
THE TRUE FINAL POSITION AND TYPE OF ALL SURVEY
MARKS PLACED PERTAINING TO THIS PLAN.

MNG.
MNG Ref : 94134dp-2121 -NAC1 - DP408508.CSD

Allegretto Date: 7/10/2016
LICENSED SURVEYOR 2016.04.04 14:20:52 +0800 DATE

Landgate

DEPOSITED PLAN
408508
SHEET 04 OF 06 SHEETS
VERSION 3

DEVELOPMENT
ASSESSMENT PANEL
APPROVED
12-Mar-2024

FOR HEADING SEE SHEET 1
 FOR INTERESTS AND NOTIFICATIONS
 SEE SHEET 3

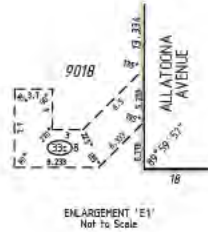
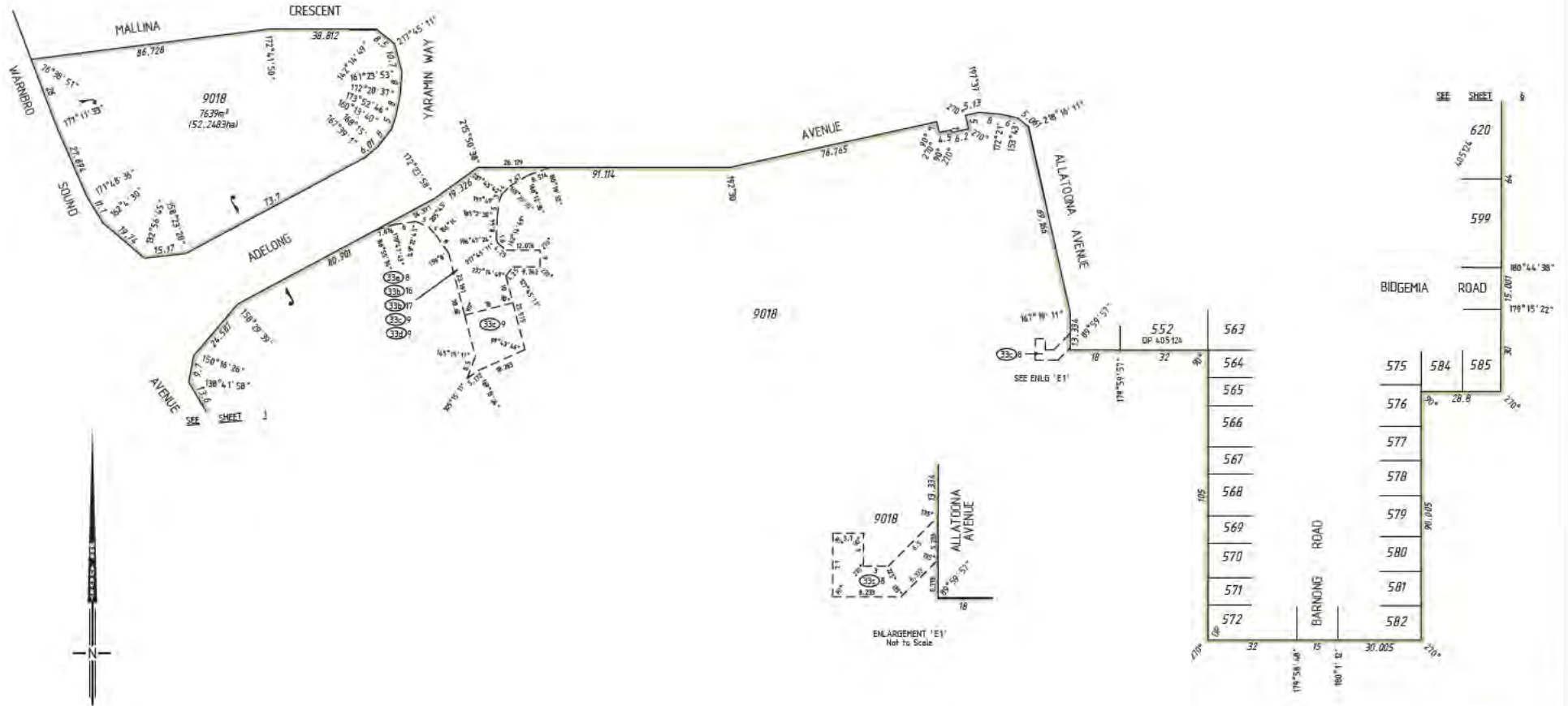

SEE SHEET 8	620	8
	599	4
BIDGEMIA ROAD		180°44'38"
		179°15'22"
575	584	585
576	28.8	270°
577		
578		
579		
580		
581		
582		
		90.005
		270°
		119°58'48"
		180°1'0"
		30.005
		270°

DEVELOPMENT
 ASSESSMENT PANEL
 APPROVED
 12-Mar-2024

SURVEY CARRIED OUT UNDER REG 26A
 SPECIAL SURVEY AREA GUIDELINES
 SEE SURVEY SHEETS FOR SURVEY INFORMATION
 USE ONLY THE SURVEY SHEET/S WHEN DETERMINING
 THE TRUE FINAL POSITION AND TYPE OF ALL SURVEY
 MARKS PLACED PERTAINING TO THIS PLAN.

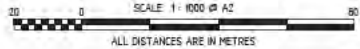

HELD BY LANDGATE IN DIGITAL FORMAT ONLY

MNG
 MNG Ref - 94 134dp-2121 -NAC1 - DP405805.CSD
 Darin T Origan
 2016.04.04 14:21:01 +0900
 LICENSED SURVEYOR DATE

DEPOSITED PLAN
408508
 SHEET 05 OF 06 SHEETS
 VERSION 3

LANDGATE COPY OF ORIGINAL NOT TO SCALE 22/12/2022 09:00 AM Request number: 64532003

FOR HEADING SEE SHEET 1
FOR INTERESTS AND NOTIFICATIONS
SEE SHEET 3

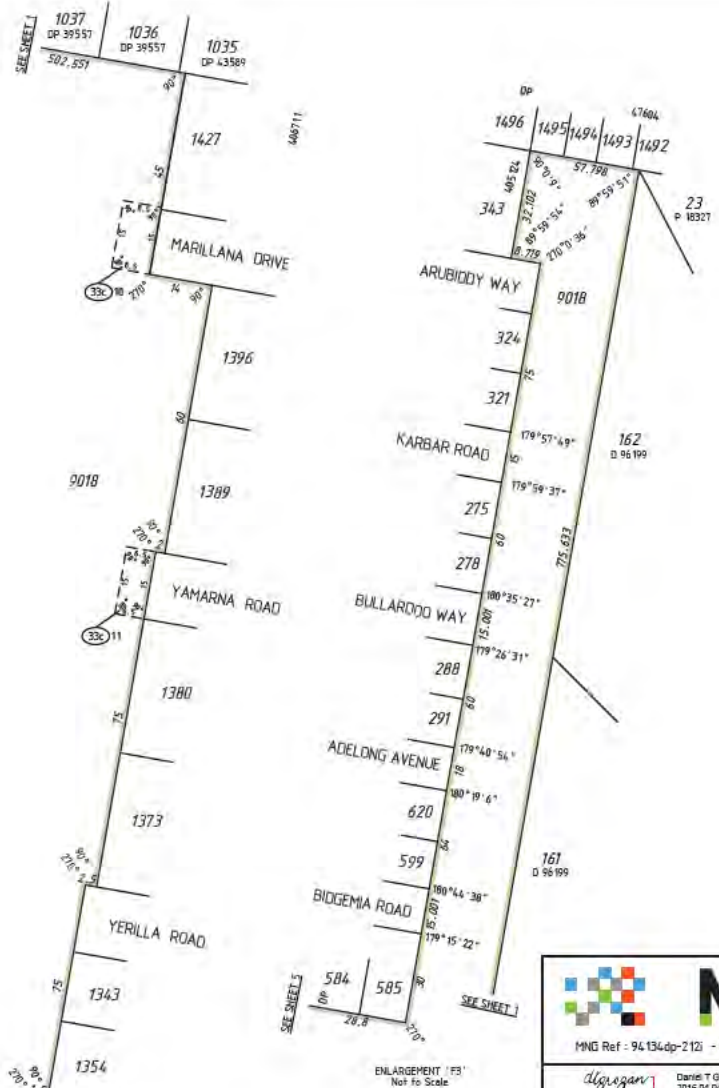
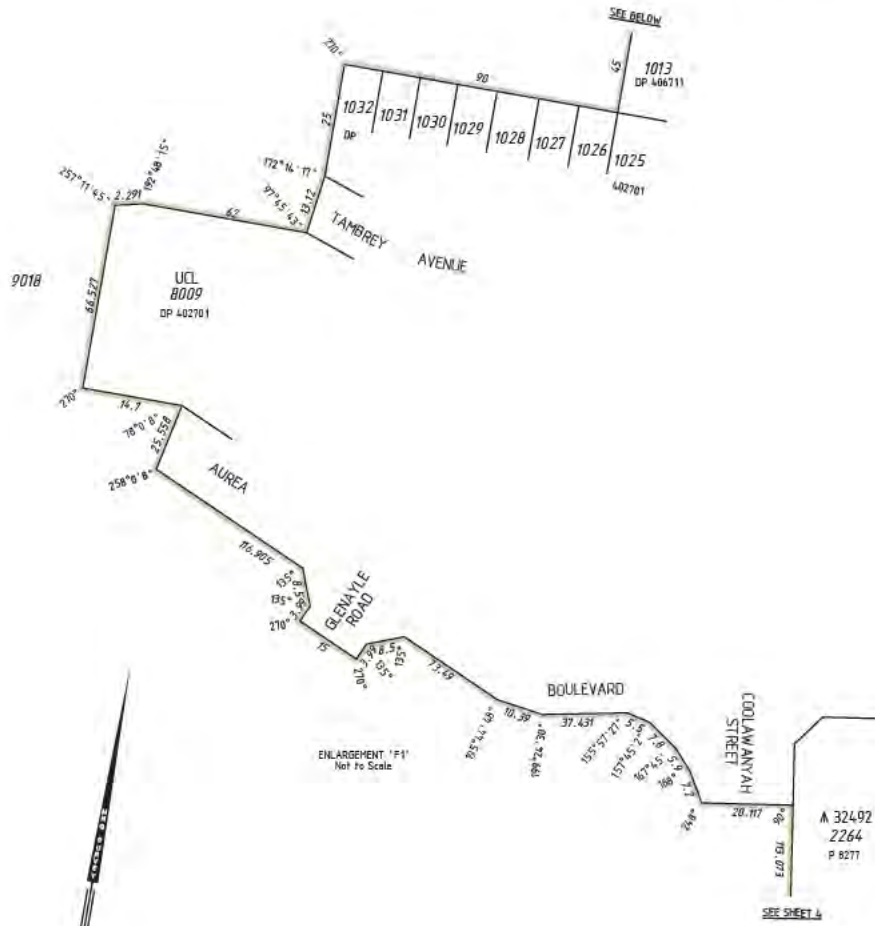

DEVELOPMENT
ASSESSMENT PANEL
APPROVED
12-Mar-2024

SURVEY CARRIED OUT UNDER REG 26A
SPECIAL SURVEY AREA GUIDELINES
SEE SURVEY SHEETS FOR SURVEY INFORMATION
USE ONLY THE SURVEY SHEET/S WHEN DETERMINING
THE TRUE FINAL POSITION AND TYPE OF ALL SURVEY
MARKS PLACED PERTAINING TO THIS PLAN.
HELD BY LANDGATE IN DIGITAL FORMAT ONLY

MNG.
MNG Ref : 94134dp-212i - NAC1 - DP408508.CSD

alqasari Daniel T Groen
LICENSED SURVEYOR 2016.04.04 14:21:10 +0800
DATE

Landgate

DEPOSITED PLAN
408508
SHEET 06 OF 06 SHEETS
VERSION 3

AMENDMENTS TABLE (SURVEY SHEETS ONLY)

VER.	AMENDMENT	AUTHORISED BY	DATE

FOR SURVEY INFORMATION ONLY
SURVEY INFORMATION COMPRISES
SURVEY SHEETS...A:B...

EFB 123116/9298
Brass Plaque in Concrete

EFB 136494/9698
Nail in Beam

EFB 123116/9297
Drill Hole

TO EFB 136494/9694
Spike in Pavement

TD EFB 123116/9295
Nail

9502

TO EFB 136494/9695
Deck Spike

EFB 136494/9695
Deck Spike

THUNDEARRA DRIVE

on footpath

in concrete

in concrete

in concrete

in concrete

in concrete

in concrete

in concrete

in concrete

in concrete

in concrete

in concrete

in concrete

in concrete

in concrete

in concrete

in concrete

in concrete

in concrete

in concrete

in concrete

in concrete

in concrete

in concrete

in concrete

in concrete

in concrete

in concrete

in concrete

in concrete

in concrete

in concrete

in concrete

in concrete

in concrete

in concrete

in concrete

in concrete

in concrete

EFB 123116/9287
Drill Hole

EL WIRE

in footpath

in face of wall

in face of wall

in face of wall

in face of wall

in face of wall

in face of wall

in face of wall

in face of wall

in face of wall

in face of wall

in face of wall

in face of wall

in face of wall

in face of wall

in face of wall

in face of wall

in face of wall

in face of wall

in face of wall

in face of wall

in face of wall

in face of wall

in face of wall

in face of wall

in face of wall

CONNECTION FROM EFB 123116/9299
TO EFB 136494/9700
DISTANCE 41.536

DEVELOPMENT ASSESSMENT PANEL

APPROVED

12-Mar-2024

EFB 136494/9700
Spike in Pavement

AUREA

in footpath

in footpath

in footpath

in footpath

in footpath

in footpath

in footpath

HELD BY LANDGATE IN DIGITAL FORMAT ONLY

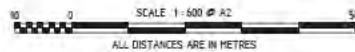

- LEGEND**
- Standard Survey Mark (SSM)
 - Permanent Survey Mark (PSM)
 - Permanent Control Mark (PCM)
 - Temporary Control Mark (TCM)
 - Peg unless stated otherwise
 - Nail
 - Nail and Plate
 - Spike
 - Drill Hole
 - Deck Spike
 - Deck Spike and Plate

SURVEYOR'S CERTIFICATE - REG 54

I, Stephen PINKER hereby certify that this plan is accurate and is a correct representation of the -
 (a) survey; and/or
 (b) calculations from measurements recorded in the field records.
 If delete if inapplicable.
 undertaken for the purposes of this plan and that it complies with the relevant written law(s) in relation to which it is lodged.

SURVEYOR'S CERTIFICATE - REG 55(d)

The marks shown on these plans of survey were in place on 10/05/2016

Stephen Pinker
2016.05.20 15:32:28
+08:00

LICENSED SURVEYOR DATE

SURVEY CARRIED OUT UNDER REG 26A SPECIAL SURVEY AREA GUIDELINES

ALL BEARINGS AND DISTANCES ON THIS SHEET ARE THE RESULT OF LEAST SQUARES ADJUSTMENTS CARRIED OUT ON FIELD OBSERVATIONS

GRID DATUM IS PC694

SURVEY SHEET ADDED
DATE: 13/6/2016 BOO

MNG

MNG Ref: 94 134ss-224a - EFB 136494, CSD

Landgate

GOVERNMENT OF WESTERN AUSTRALIA

DEPOSITED PLAN
408508
SURVEY SHEET A
VERSION 1

FOR SURVEY INFORMATION ONLY

SURVEY INFORMATION COMPRISES
SURVEY SHEETS...A,B....

SURVEY CARRIED OUT UNDER REG 26A
SPECIAL SURVEY AREA GUIDELINES

ALL BEARINGS AND DISTANCES ON THIS SHEET
ARE THE RESULT OF LEAST SQUARES ADJUSTMENTS
CARRIED OUT ON FIELD OBSERVATIONS

GRID DATUM IS PC684

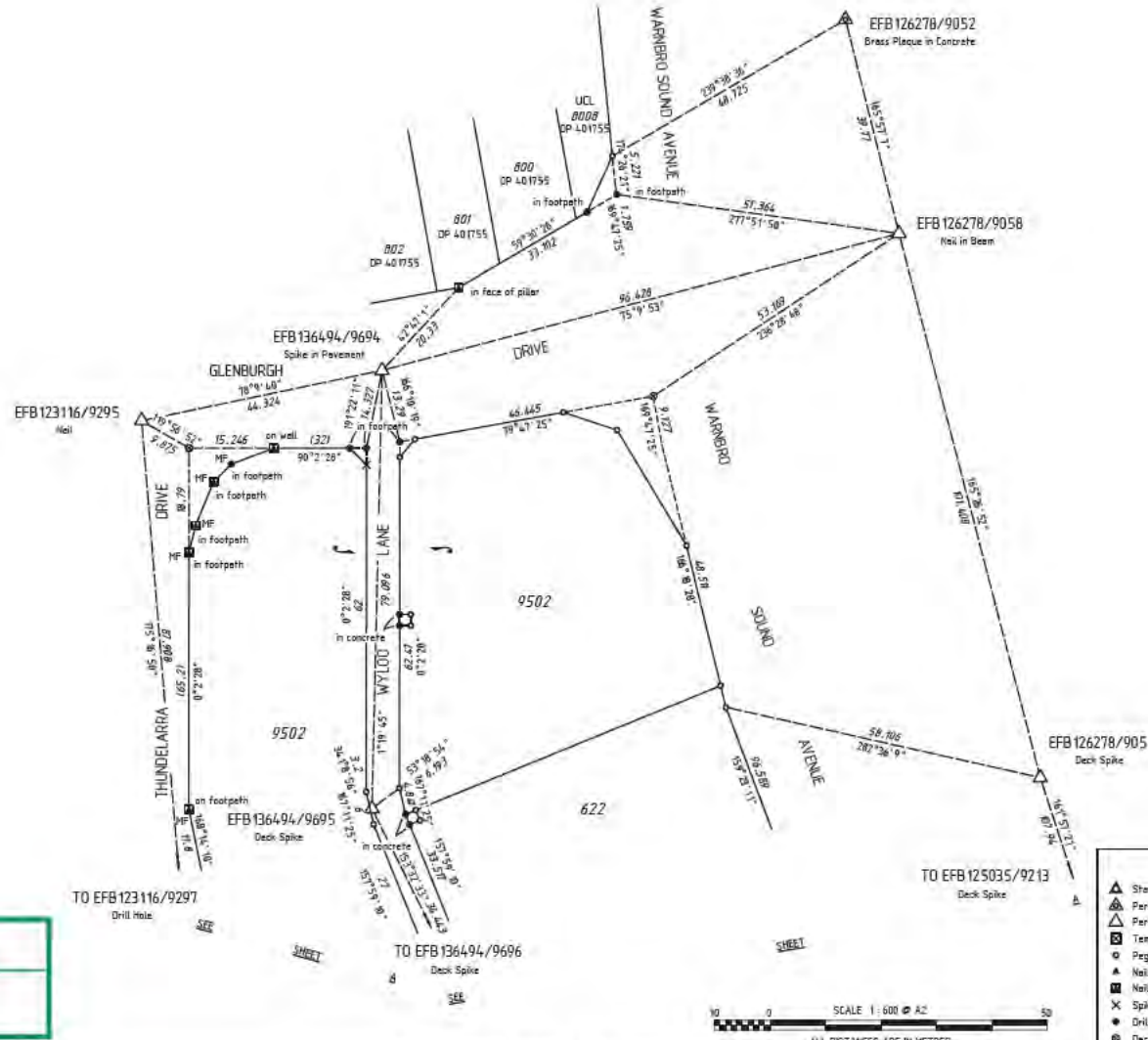

SURVEYOR'S CERTIFICATE - REG 54

I, Stephen PINKER
hereby certify that this plan is accurate and
is a correct representation of the -
a) survey, and/or
b) calculations from measurements
recorded in the field records,
if delete is inapplicable.
undertaken for the purposes of this plan
and that it complies with the relevant
written law(s) in relation to which it is
lodged.

SURVEYOR'S CERTIFICATE - REG 55(d)

The marks shown on these plans of survey
were in place on 10/05/2016

Stephen Pinker
Stephen Pinker
2016.05.20 15:32:34
+08'00'
LICENSED SURVEYOR DATE



- LEGEND
- ▲ Standard Survey Mark (SSM)
 - △ Permanent Survey Mark (PSM)
 - ▢ Permanent Control Mark (PCM)
 - Temporary Control Mark (TCM)
 - Peg unless stated otherwise
 - ▲ Nail
 - Nail and Plate
 - × Spike
 - Drill Hole
 - Deck Spike
 - Deck Spike and Plate

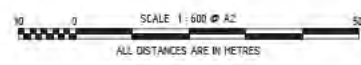

DEVELOPMENT
ASSESSMENT PANEL
APPROVED
12-Mar-2024

DEPOSITED PLAN
408508
SURVEY SHEET B
VERSION 1



Engineering a better future for **over 20 years!**

Golden Bay Neighbourhood Centre

No.2 Aurea Boulevard Golden Bay

Revised Transport Impact Assessment

PREPARED FOR:
Ladybug Twenty Pty Ltd

May 2023

DEVELOPMENT
ASSESSMENT PANEL

APPROVED
12-Mar-2024

Document history and status

Author	Revision	Approved by	Date approved	Revision type
M Rasouli	r01	B Bordbar	29/12/2022	Draft
M Rasouli	r01a	B Bordbar	31/01/2023	Second Draft
M Rasouli	r01b	B Bordbar	08/02/2023	Final
M Rasouli	r01c	B Bordbar	02/05/2023	Revised Final

File name: t22.035.mr.r01c.docx

Author: Mohammad Rasouli

Project manager: Mohammad Rasouli

Client: Ladybug Twenty Pty Ltd

Project: Golden Bay Neighbourhood Centre

Document revision: r01c

Project number: t22.035



TABLE OF CONTENTS

1	INTRODUCTION	5
2	DEVELOPMENT PROPOSAL	7
2.1	STACKING CAPACITY FOR SERVICE STATION	8
3	EXISTING SITUATION	12
3.1	EXISTING ROAD NETWORK.....	12
3.2	EXISTING TRAFFIC VOLUMES ON ROADS.....	14
3.3	HEAVY VEHICLES.....	16
3.4	PUBLIC TRANSPORT ACCESS.....	16
3.5	PEDESTRIAN AND CYCLIST FACILITIES	17
3.6	CRASH DATA	18
4	CHANGES TO SURROUNDING TRANSPORT NETWORKS	19
5	INTEGRATION WITH SURROUNDING AREA	20
6	TRAFFIC ASSESSMENT	21
6.1	ASSESSMENT PERIOD	21
6.2	TRIP GENERATION AND DISTRIBUTION.....	21
6.3	TRAFFIC FLOW FORECASTS	24
6.4	ANALYSIS OF LOCAL INTERSECTIONS & CROSSOVERS.....	27
6.5	IMPACT ON SURROUNDING ROADS.....	30
6.6	IMPACT ON NEIGHBOURING AREAS	31
6.7	TRAFFIC NOISE AND VIBRATION.....	31
7	PARKING	32
8	PROVISION OF HEAVY VEHICLES	38
9	CONCLUSIONS	39

APPENDIX A : TRANSORE RESPONSES TO THE CITY COMMENTS

APPENDIX B: PROPOSED DEVELOPMENT PLAN

APPENDIX C: INTERSECTION ANALYSIS - SIDRA RESULTS

APPENDIX D: TURN PATH ANALYSIS



REPORT FIGURES

Figure 1: Location of the subject site	6
Figure 2. Proposed access/egress system	7
Figure 3. Peak “cheap fuel” hour queuing analysis	10
Figure 4: Movement of a B99 car around parked vehicles at the bowsers	11
Figure 5: Existing road hierarchy	12
Figure 6: Aurea Blvd adjacent to the subject site (looking east)	13
Figure 7: Thundelarra Dr adjacent to the subject site (looking south).....	13
Figure 8: Existing traffic counts AM/ PM peak hour	15
Figure 9. Existing heavy vehicle road network classification (RAV)	16
Figure 10: Existing bus routes (source: Transperth)	17
Figure 11: Bike map (source: Department of Transport).....	18
Figure 12: Proposed development traffic – AM Weekday, PM Weekday	23
Figure 13: Total (2023) traffic – AM Weekday, PM Weekday	25
Figure 14: Total (2033) traffic – AM Weekday, PM Weekday	26
Figure 15: SIDRA Network Model.....	28
Figure 16: Weekday AM and PM peak hour network analysis – queue storage ratio (2023)	29
Figure 17: Weekday AM and PM peak hour network analysis – queue storage ratio (2033)	30

REPORT TABLES

Table 1. Crash Statistics for the Aurea Blvd / Warnbro Sound Avenue.....	18
Table 2: Weekday daily, morning peak and afternoon peak hour trip generation for the proposed land uses.....	22
Table 3: Passing trade and primary trips components of the trip generation.....	22
Table 4: Car parking assessment	32
Table 5: Percentage of parking demand temporal analysis – typical Friday	33
Table 6: Parking demand temporal analysis – typical Friday	34
Table 7: Percentage of Parking demand temporal analysis – typical Saturday.....	36
Table 8: Parking demand temporal analysis – typical Saturday	37



1 Introduction

This Revised Transport Impact Assessment (TIA) has been prepared by Transcore on behalf of Ladybug Twenty Pty Ltd with regards to the proposed Golden Bay Neighbourhood Centre to be located at 2 Aurea Boulevard, Golden Bay.

This revised TIA aims to address the City of Rockingham's comments on the original TIA prepared by Transcore in February 2023. **Appendix A** of this TIA details the City's comments and Transcore responses to each comment. Accordingly, the development plan has been updated to address the relevant comments by City and this revised TIA also reflects the updated development plan.

The site is located at the north-west corner of the existing signalised intersection of Warnbro Sound Avenue/Aurea Boulevard (refer **Figure 1**). Thudelarra Drive forms the western boundary of the site and Aurea Blvd is located to the south of the site.

This revised TIA will establish the traffic generation and distribution of the proposed development. The operation of the proposed development left in/left out crossover on Aurea Blvd and the nearby intersections (Warnbro Sound Ave/ Aurea Blvd and Thudelarra Dr/ Aurea Blvd) for existing, post development and 10-year post development scenarios will also be investigated in this TIA.

This revised TIA also will review the development plan with respect to parking layout, parking supply and demand, access, egress, circulation and fuel tanker and service vehicle movements.

It should be noted that Transcore was involved with a similar development on the opposite side of Aurea Boulevard. This development has been approved by JDAP and is operational.





Figure 1: Location of the subject site

2 Development Proposal

The development proposal is for a Neighbourhood Centre comprising the following elements:

- Two Fast-food outlets with drive through facilities (approximately 525m² GFA in total);
- A Liquor Store with drive through facility (approximately 230m² GFA);
- A Supermarket (approximately 1,165m² GFA);
- Specialty shops (approximately 255m² GFA); and,
- A Service Station with eight filling points.

Parking provision shown in the development plan (**Appendix B**) is a total of 147 bays including four on-street bays and eight ACROD Bays. More discussions on parking supply and demand are provided in **section 7** of this TIA.

The proposed access/egress system intended to serve the development is shown in **Figure 2** and comprises the following elements:

- A full movement crossover on Thundelarra Drive (crossover 1);
- A left in/ left out crossover on Aurea Boulevard (crossover 2); and,
- A full movement crossover on Wyloo Lane (crossover 3).



Figure 2. Proposed access/egress system

The Thundelarra Drive crossover is an existing crossover which would be modified slightly to accommodate the turning movements of service vehicles and fuel tanker.

The proposed crossover on Aurea Blvd is a left in/ left out crossover and would be located before the 70-degree left turn slip lane on Aurea Blvd. This crossover is important for effective and efficient circulation system for the development and in particular the land uses closest to the Aurea Boulevard.

The stacking capacity of the proposed fast-food outlets is reviewed against the RTA Guidelines requirements.

Section 5.8.1 of RTA Traffic Generating Developments document deals with the parking requirements for the drive-in and take-away food outlets. With respect to the drive through facilities this section states that:

An exclusive area for queuing of cars for a drive through is required (queue length of 5 to 12 cars measured from pick up point). There should also be a minimum of four car spaces for cars queued from the ordering point.

The proposed fast-food outlet 1 (265m²) provides a drive through facility with two Customer Order Booth (COB) and provision of 13 car stacking capacity including two waiting bays with minimum four car spaces available from the ordering points. Accordingly, the proposed drive through facility for the fast-food outlet 1 meets and exceeds the RTA drive through requirements.

The proposed fast-food outlet 2 (260m²) provides a drive through facility with two Customer Order Booth (COB) and provision of 11 car stacking capacity including two waiting bays with minimum four car spaces available from the ordering points. Accordingly, the proposed drive through facility for the fast-food outlet 2 meets the RTA drive through requirements.

The proposed liquor store drive through facility also provides eight car stacking capacity which is expected to be sufficient for its operations.

The stacking capacity of the proposed service station have been assessed in more detail in the next section of the report.

2.1 Stacking Capacity for service station

The stacking capacity of the service station component of the proposed development and detailed queue analysis at the filling points has been assessed in more detail to investigate the impacts of the higher than average site patronage during peak weekday operational periods. This analysis was undertaken to confirm the capacity of the service station to operate satisfactory under amplified traffic activity conditions (i.e. "cheap fuel" day).

Based on the estimated peak hour trip generation for the service station outlined in this report, it is estimated that the subject service station would attract up to 56 vehicles during the regular weekday PM peak hour (busiest peak hour). In order to

ensure a robust assessment, it is assumed that the trade on “cheap fuel” day would be 50% higher than the typical peak weekday PM hour. Accordingly, it is conservatively assumed that the proposed service station would attract about 84 cars per hour on this occasion.

The experience indicates that, under normal circumstances, the rate of service per fill point (time taken for a vehicle to arrive, park at a fill point, get fuel, pay for fuel and leave the fill point and service station site) is usually between 2-3 minutes. In some circumstances refuelling time may extend to about 5 minutes when window washing or other similar activities are practiced. However, during the “cheap fuel” day periods and due to high turnover of vehicles and “pressure” from the patrons waiting behind the parked vehicle to access the bowser, the refuelling activity is always shortened and typically in order of up to 3min maximum. In this case, and in order to allow for a robust assessment, the service time is assumed to be conservatively 4 minutes. Accordingly, a service rate of 240sec (15 vehicles per hour) was assumed for weekday PM peak “cheap fuel” peak hour.

It is assumed that all bowsers will be in operation during the peak periods, giving an order taking service rate and capacity of 120 vehicles per hour, which is significantly more than the estimated higher ‘cheap fuel day’ PM peak hour trip generation. It is also assumed that cars would enter the service channel with the shortest queue, therefore over the peak hour the transactions at each service channel would be evenly split.

A queue length analysis was undertaken to assess the provision of storage for vehicles within the service channels. For this purpose, an M/M/1 queuing model was adopted for each bowser. The M/M/1 is a single-server queue model that can be used to approximate simple systems.

The queuing model adopts the following assumptions:

- ✦ Vehicles arrive unevenly following Poisson’s probability distribution;
- ✦ Service time is exponentially distributed;
- ✦ There is one server per queue, i.e. there are 8 queues, one for each bowser;
- ✦ The capacity of the queue in which arriving users wait before being served is infinite (for the purposes of identifying queue space requirements);
- ✦ The population of users (i.e. the pool of users) available to join the system is infinite; and,
- ✦ The queue is serviced on a first come, first served basis.

The results of the queuing analysis are detailed in **Figure 3**. In summary, critical “cheap fuel” hour queuing analysis of the service station established the following for the worst-case scenario:

- ✦ The system utilisation is at 70% during the “cheap fuel” hour;
- ✦ The expected number in the system (refuelling) is 7 vehicles;
- ✦ The expected time in the queue is 267 seconds; and,
- ✦ The 95th percentile queue within the whole system is 12 cars (8 cars refuelling and 4 cars waiting).

The queue length usually adopted for robust analysis is the 95th percentile queue. Assuming equal queue distribution it is estimated that in the worst-case scenario there will be one vehicle waiting behind each refuelling vehicle at four bowsers. The service station layout can accommodate this level of queuing.

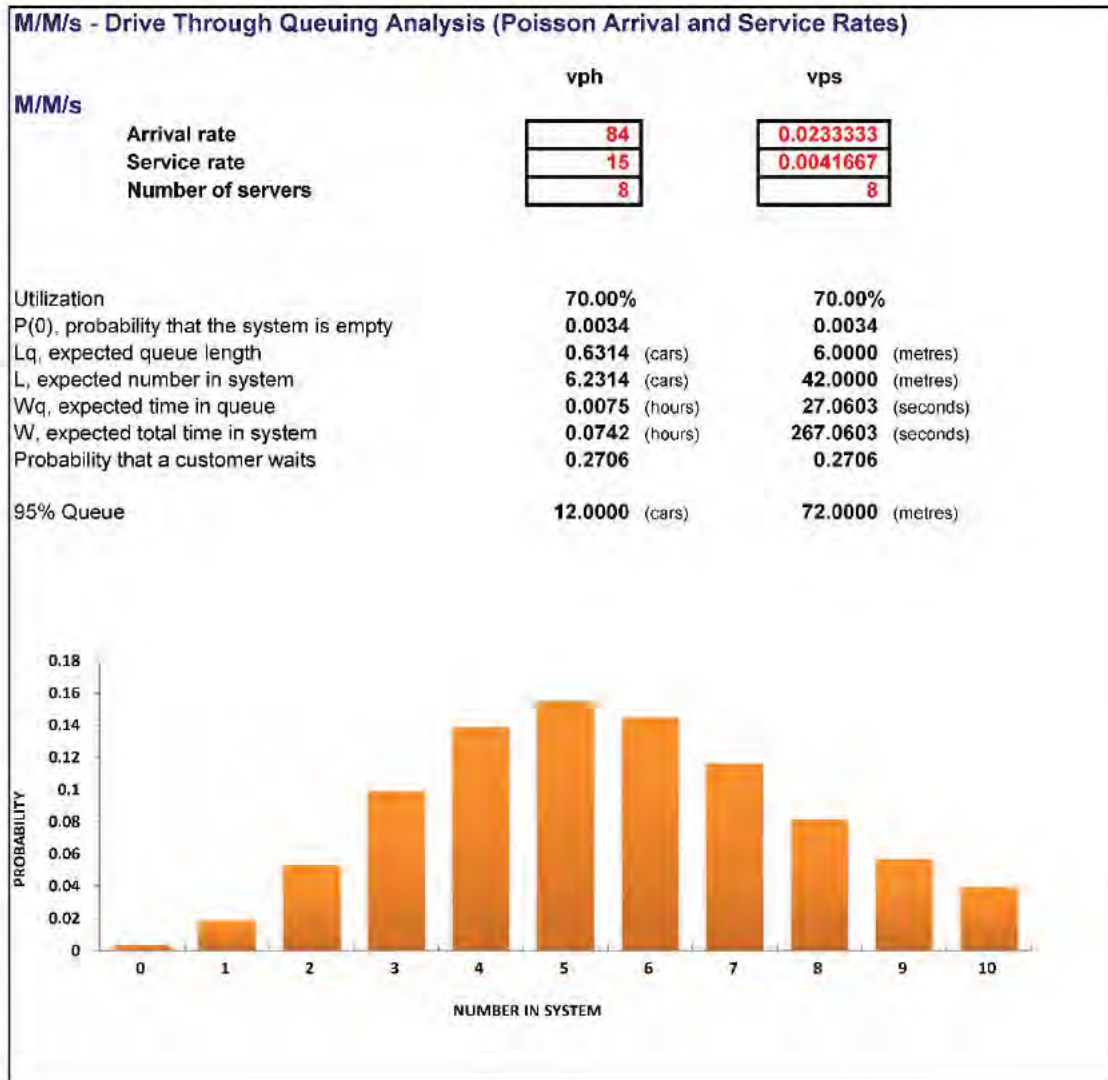

Figure 3. Peak “cheap fuel” hour queuing analysis

To investigate if vehicles are waiting behind fill points, still a B99 car can navigate the site, Sk15a in **Figure 4** is prepared which shows that at worst case scenario that 2 vehicles wait at both sides of the last two bowsers, still a B99 car can move around the parked cars. Regardless, there will be an alternative anti-clockwise route also available for vehicles to access the parking bays in front of the shop.



2 Aurea Blvd, Golden Bay
B99 Passenger Car

LEGEND
Vehicle Body
Wheel Path
300mm Clearance

t22.035.sk15a

1/5/2023

Scale: 1:250 @ A3



Figure 4: Movement of a B99 car around parked vehicles at the bowers

3 Existing Situation

3.1 Existing Road Network

The road hierarchy of the surrounding roads in accordance with Main Roads WA Functional Road Hierarchy is illustrated in **Figure 5**. As evident Aurea Blvd is classified as a Local Distributor and Thundelarra Drive is classified as an Access Road in the Main Roads WA *Functional Road Hierarchy*.



Figure 5: Existing road hierarchy

Aurea Boulevard as shown in **Figure 6**, is constructed as single carriageway standard with a solid median, on-street parking bays, on road cycle lanes and pedestrian paths on both sides of the road in the vicinity of the subject site. Aurea Boulevard operates under the default, built up area speed limit of 50km/h.

Aurea Boulevard connects to Thundelarra Drive in the form of a roundabout intersection and to Warnbro Sound Avenue as a signalised intersection.



Figure 6: Aurea Blvd adjacent to the subject site (looking east)

Thundelarra Drive as shown in **Figure 7**, is constructed as a single carriageway with on- road cycle lanes and shared paths on both sides of the road. It operates under the built-up area speed limit of 50km/h.



Figure 7: Thundelarra Dr adjacent to the subject site (looking south)

Warnbro Sound Avenue forms the eastern boundary of the site and is constructed as dual carriageway standard road with shared paths on paths on both sides of the road. Warnbro Sound Ave is classified as a Distributor B road in the Main Roads WA Perth Metropolitan Area Functional Road Hierarchy. The intersection of Warnbro Sound Avenue/ Aurea Blvd/ Adelong Ave in the form of a signalised intersection.

3.2 Existing Traffic Volumes on Roads

The latest SCATS data the signalised intersection of Warnbro Sound Avenue/ Aurea Blvd/ Adelong Ave was sourced and analysed to establish the hourly and daily traffic volumes at the intersection.

Review of the February 2022 SCATS data indicated that Warnbro Sound Avenue and Aurea Blvd carried approximately 9,700vpd and 3,182vpd during the weekday.

Transcore also undertook video traffic counts at the existing roundabout intersection of Aurea Blvd/ Thundelarra Drive during the weekday AM (8:00 – 9:00) and PM (4:00-5:00) peak hours in September 2022. **Figure 7** shows the existing turning movements at the intersections.

The video counts indicated slightly higher traffic volumes on Aurea Blvd. Therefore, the SCATS traffic data were factored up to match the outcome of the video traffic counts on Aurea Blvd, resulting in a robust assessment.

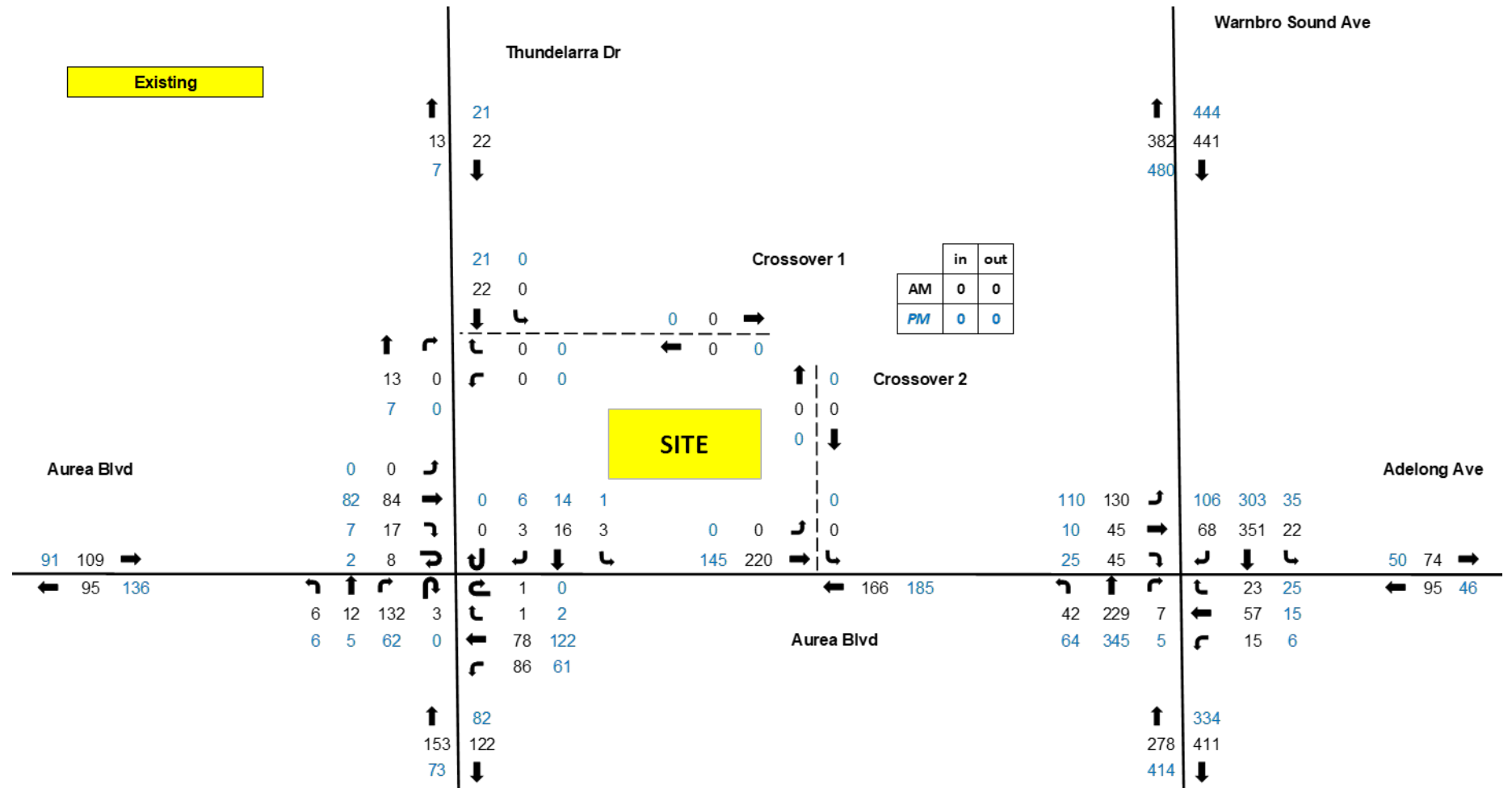

Figure 8: Existing traffic counts AM/ PM peak hour

3.3 Heavy Vehicles

Restricted Access Vehicle (RAV) Network routes are designated for access by large heavy vehicle combinations, which is managed by Main Roads WA.

As shown in **Figure 9**, the adjacent roads are not part of the RAV network and would be able to accommodate "as of right" vehicles (up to 19m semi-trailers).



Figure 9. Existing heavy vehicle road network classification (RAV)

3.4 Public Transport Access

Available nearby public transport services are present in **Figure 10**. Bus route 558 provides a connection between Mandurah and Rockingham with Bus stops located on Warnbro Sound Avenue. This bus route operates on a half hourly basis throughout the day with additional services provided during the peak hour. This bus route provides an opportunity to transfer to other connecting bus and rail services.



Figure 10: Existing bus routes (source: Transperth)

3.5 Pedestrian and Cyclist Facilities

The Department of Transport’s Perth Bike Map series (refer **Figure 11**) shows that “High Quality Shared paths” are currently in place on both sides of Warnbro Sound Avenue. Shared Paths are also in place on both sides of Aurea Blvd and Thundelarra Drive. Both these roads also entail on road cycle lanes.

Pedestrian will have direct access to the proposed development via the existing external path network along the surrounding roads.



Figure 11: Bike map (source: Department of Transport)

3.6 Crash Data

Information available on the Main Roads WA website indicates only one crash for the existing roundabout intersection of Aurea Blvd and Thundelarra Drive during the last five-year period ending in December 2021. This crash entailed no casualty.

The signalised intersection of Aurea Blvd / Warnbro Sound Avenue recorded a total of 4 road crashes with no casualty during the last five-year period ending in December 2021 as illustrated in **Table 1**.

The crash records over the last 5 years demonstrate that the road network in this vicinity has been constructed to a high standard with no particular safety issue.

Table 1. Crash Statistics for the Aurea Blvd / Warnbro Sound Avenue

Intersection				Total Crashes	Casualty
Aurea Blvd / Warnbro Sound Avenue				4	0
Rear End	Non collision	Pedestrian	Daylight	PDO Major	Dry
1	2	0	2	1	4

4 Changes to Surrounding Transport Networks

There are no changes to the surrounding road network as part of the proposed development. A left in/ left out crossover is proposed on Aurea Blvd fronting the site as part of this proposal with a connection to Wyloo Lane. The Thundelarra Drive crossover shown in the development plan is an existing crossover which would be modified slightly as part of the proposed development.

5 Integration with Surrounding Area

The proposed development entails a neighbourhood centre which is in line with the existing and future surrounding land uses in the area.



6 Traffic Assessment

6.1 Assessment Period

The assessment years that are adopted for the analysis are 2023 and 2033.

6.2 Trip Generation and Distribution

The trip generation of the proposed land uses was sourced from the RTA NSW Guide to Traffic Generating Developments and the Institute of Transport Engineers Trip Generation Manual (11th Edition).

The trip rates which were used to estimate the proposed development traffic generation are shown in **Table 2**. This table also summarises the trip generation of the proposed development. **Table 3** shows the passing trade component of the development.

Due to the land use mix within the proposed Lots incidences of multi-purpose trips¹ (i.e., cross-trade) are anticipated. Accordingly, the applied cross-trade adjustment is calculated to result in approximately 25% reduction in total trip generation (in line with RTA NSW Guidelines).

Therefore, the net addition of traffic when accounting for passing trade is **+123vph** (AM peak hour) and **+213vph** (PM peak hour) on the surrounding road network.

The distribution of traffic to and from the proposed developments was evaluated by considering the catchment area of the proposed development as well as the available access and egress routes to and from the site. Accordingly, total development traffic is shown in **Figure 11**.

¹ Multi-purpose trips are incidences where more than one shop/outlet are visited within the development (also referred to as "cross-trade")

Table 2: Weekday daily, morning peak and afternoon peak hour trip generation for the proposed land uses

Land use	Quantity	Daily Rate	Weekd-AM Peak	Weekd-PM Peak	Cross Trade	Daily Trips	Weekd-AM trips	Weekd-PM trips	AM		PM	
									IN	OUT	IN	OUT
Fast food outlet with drive through	525	5.069	0.433	0.352	0.25	1996	170	138	85	85	69	69
Liquor	230	1.092	0	0.176	0.25	188	0	30	0	0	15	15
Supermarket	1165	1.550	0.016	0.160	0.25	1354	14	140	7	7	70	70
Specialty	255	0.330	0.004	0.042	0.25	63	1	8	0	1	4	4
Service Station	8	205.360	12.470	13.990	0.25	1232	75	84	37	38	42	42
TOTAL TRAFFIC						4834	260	401	129	131	200	201

Table 3: Passing trade and primary trips components of the trip generation

	AM		PM		
	IN	OUT	IN	OUT	
Daily Trips					
50%	998	43	43	35	35
50%	94	0	0	8	8
36%	488	3	3	25	25
28%	18	0	0	1	1
60%	739	22	23	25	25
	2337	68	69	94	94

	AM		PM		
	IN	OUT	IN	OUT	
Daily Trips					
50%	998	42	42	34	34
50%	94	0	0	7	7
36%	866	4	4	45	45
28%	45	0	1	3	3
60%	493	15	15	17	17
	2497	61	62	106	107



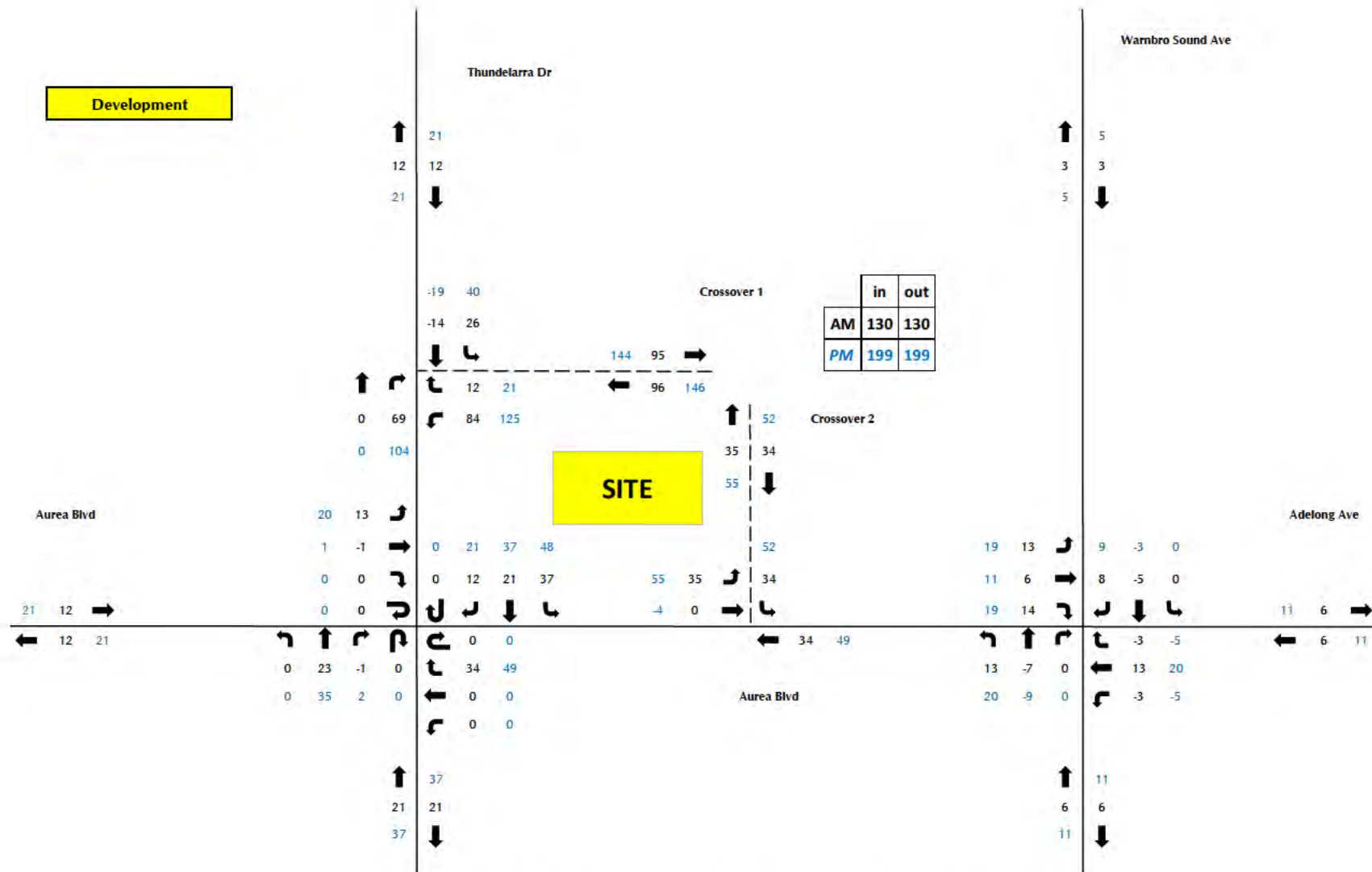

6.3 Traffic Flow Forecasts

The existing traffic counts were established by review of the SCATS data at the existing signalised intersection of Warnbro Sound Ave/ Aurea Blvd/ Adelong Ave and the video traffic counts undertaken by Transcore (refer **Figure 8**). The total post development traffic for the assessment year of 2023 and 2033 was calculated with the existing background traffic plus the development traffic. For both years 2023 and 2033 a 2% annual traffic growth was applied to the background traffic.

The total projected traffic volumes for year 2023 and 2033 are presented in **Figure 13** and **Figure 14**.



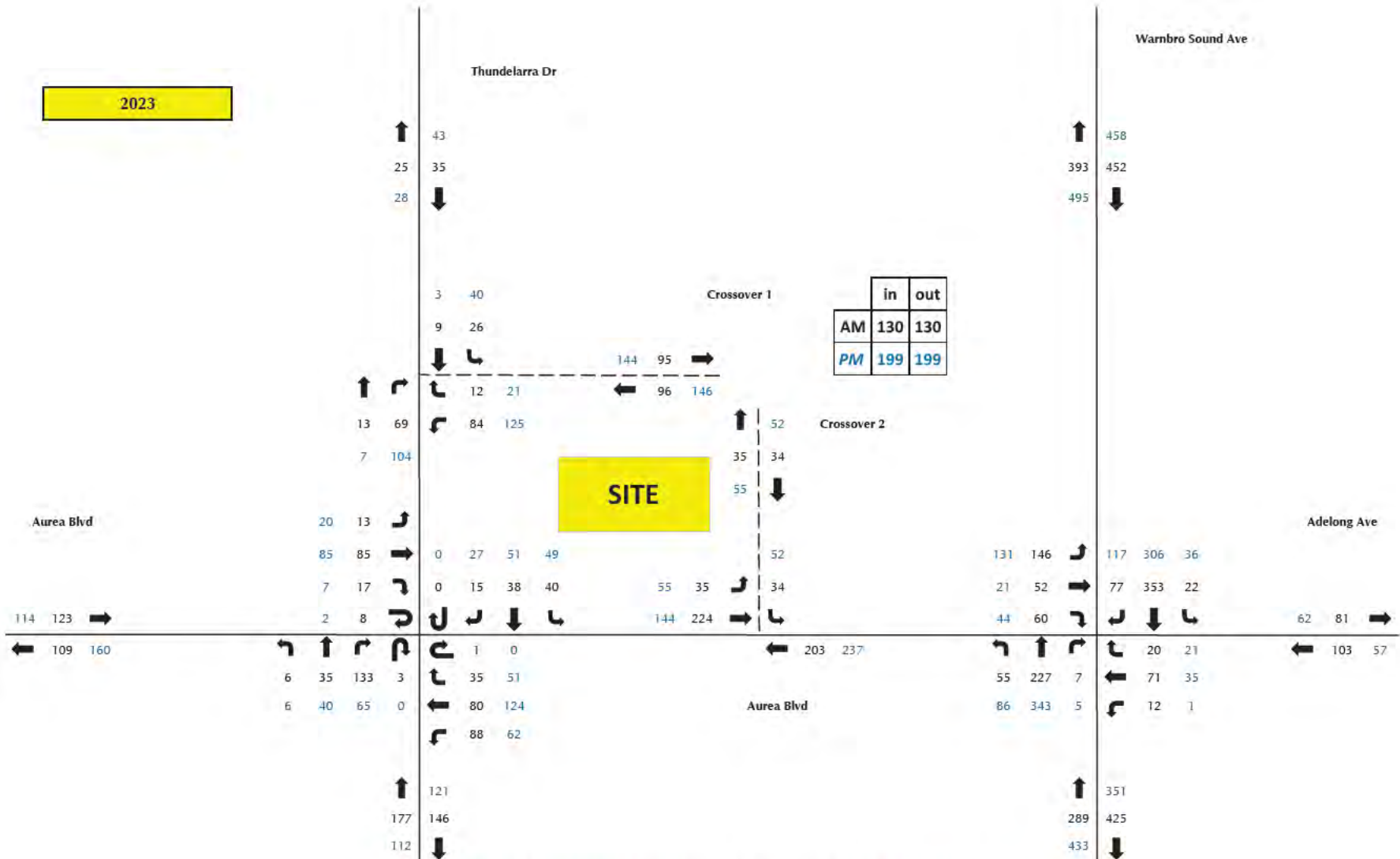

Figure 13: Total (2023) traffic – AM Weekday, PM Weekday

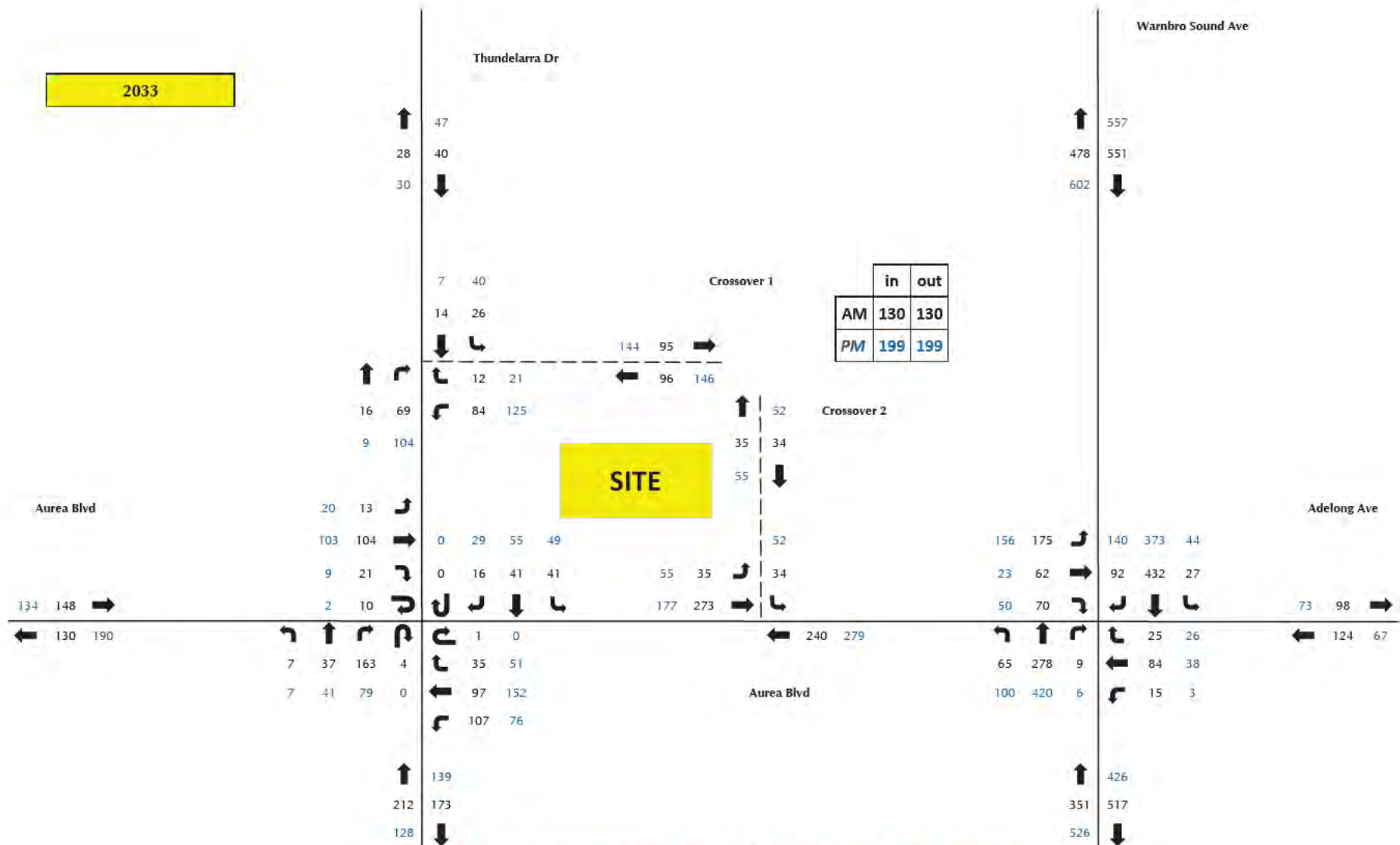

Figure 14: Total (2033) traffic – AM Weekday, PM Weekday

6.4 Analysis of Local Intersections & Crossovers

Capacity network analysis was undertaken using the SIDRA computer software package for year 2023 and 2033. SIDRA is an intersection modelling tool commonly used by traffic engineers for all types of intersections. SIDRA outputs are presented in the form of Degree of Saturation, Level of Service, Average Delay and 95% Queue. These characteristics are defined as follows:

- ✦ Degree of Saturation is the ratio of the arrival traffic flow to the capacity of the approach during the same period. The Degree of Saturation ranges from close to zero for infrequent traffic flow up to one for saturated flow or capacity.
- ✦ Level of Service is the qualitative measure describing operational conditions within a traffic stream and the perception by motorists and/or passengers. In general, there are 6 levels of service, designated from A to F, with Level of Service A representing the best operating condition (i.e., free flow) and Level of Service F the worst (i.e., forced or breakdown flow).
- ✦ Average Delay is the average of all travel time delays for vehicles through the intersection.
- ✦ 95% Queue is the queue length below which 95% of all observed queue lengths fall.

Network SIDRA models (refer **Figure 15**) were developed to assess the development crossovers on Thundelarra Drive and Aurea Blvd and nearby intersections as an integrated traffic network.

The results of the SIDRA network analysis are summarised in **Appendix C**. The SIDRA intersection models were coded with reference to Main Roads WA Operation Modelling Guidelines. All relevant parameters such as heavy vehicle groups, PCU factors etc. were coded as per the Main Roads WA Guidelines.



Figure 15: SIDRA Network Model

NEARBY INTERSECTIONS

The SIDRA analysis results and site observations indicate that the existing signalised and roundabout intersections presently operates satisfactorily (overall LoS C for signalised intersection and LoS A for roundabout intersection) with moderate queues and delays during both weekday peak hours for the signalised intersection and no queues and delays at the roundabout intersection.

The addition of the development-generated traffic resulted in negligible increases in overall queues and delays. No major change in overall LoS for the intersections is reported.

The SIDRA assessment for the 10-year post development scenario during the nominated peak periods rendered similar results to post-development scenario with marginal increases in delays and queues and no changes to the Level of Service for any of the movements of the intersections. Importantly, both intersections retain ample spare capacity for future traffic growth.

DEVELOPMENT CROSSOVERS

SIDRA analysis indicates that development crossovers will operate satisfactorily in 2023 and 2033 during assessed peak hours. All movements operate with good level of service (LoS A) with minimal delays and queuing.

NETWORK OPERATION

Relevant SIDRA network outputs were reviewed for the assessed peak hours to establish the operation of the development crossovers and the nearby intersections as an integrated network.

As detailed in **Figure 15** and **Figure 16** there are no queue back from the nearby intersections to the development crossovers. Similarly, no queue back from the development crossovers to the nearby intersections are reported.

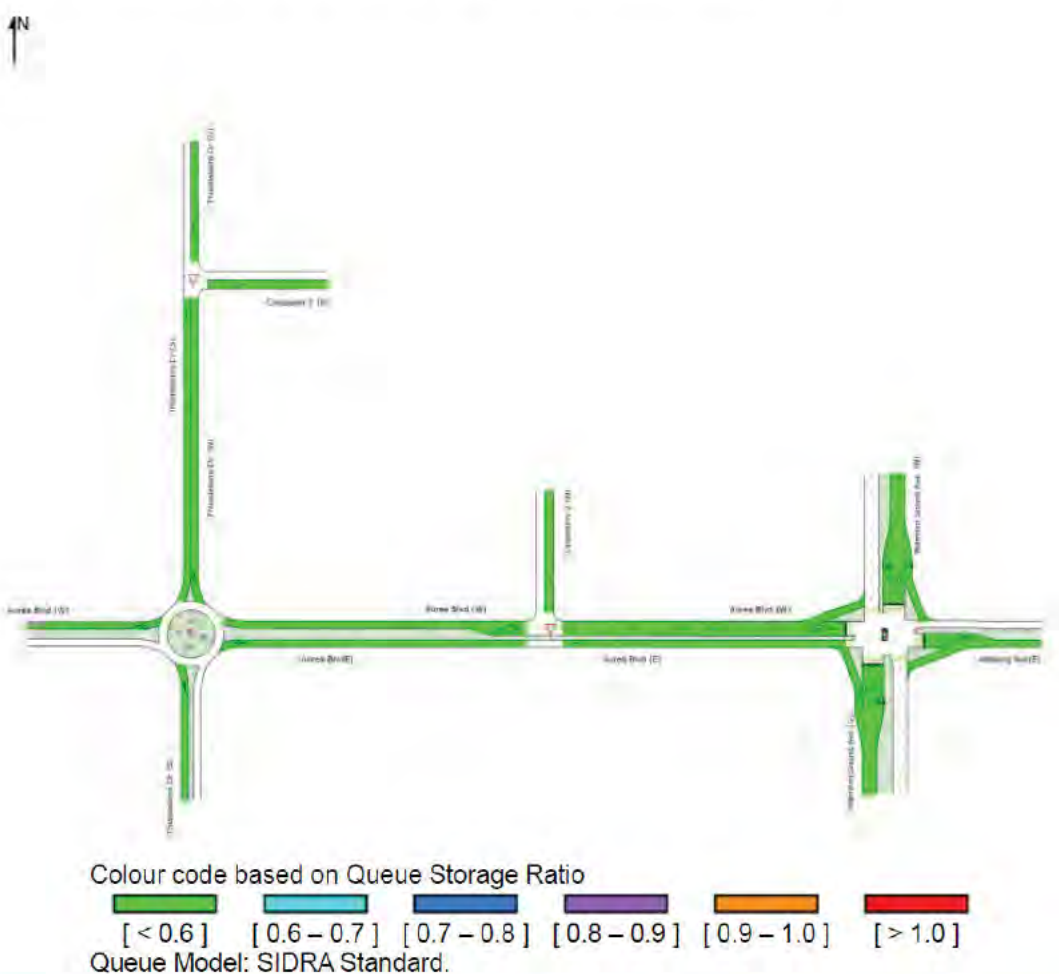

Figure 16: Weekday AM and PM peak hour network analysis – queue storage ratio (2023)

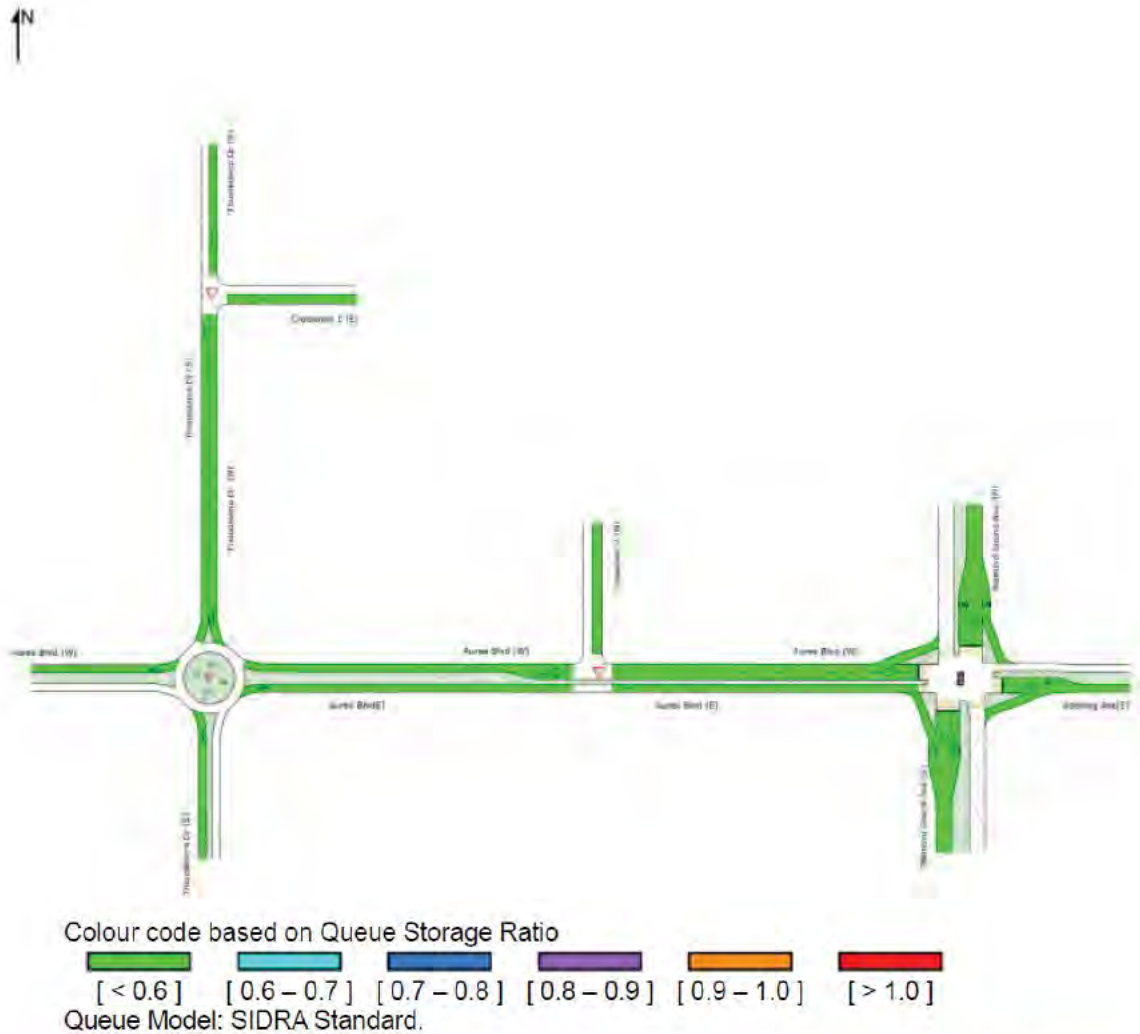

Figure 17: Weekday AM and PM peak hour network analysis – queue storage ratio (2033)

6.5 Impact on Surrounding Roads

The WAPC *Transport Impact Assessment Guidelines* (2016) provides the following guidance on the assessment of traffic impacts:

“As a general guide, an increase in traffic of less than 10 percent of capacity would not normally be likely to have a material impact on any particular section of road, but increases over 10 percent may. All sections of road with an increase greater than 10 percent of capacity should therefore be included in the analysis. For ease of assessment, an increase of 100 vehicles per hour for any lane can be considered as equating to around 10 percent of capacity. Therefore, any section of road where development traffic would increase flows by more than 100 vehicles per hour for any lane should be included in the analysis.”

The proposed development will not increase traffic on any lanes on the surrounding road network by more than 100vph, except for a short section of Thundelarra Drive between the roundabout and the development crossover which would result in total

traffic projection of about 245vph (or 2450vpd) during the PM peak hour in 2033. The current standard of Thundelarra Drive as a neighbourhood connector B road would be able to comfortably accommodate the 2033 projected traffic volumes along this section of the road.

Therefore, the proposed development will not increase traffic flows near the quoted WAPC threshold on most of the surrounding roads to warrant further detailed analysis.

6.6 Impact on Neighbouring Areas

Due to the location of the subject site, its accessibility via a major regional road, significant passing trade component and limited number of residential dwellings within the immediate vicinity, the traffic impact from the development in the area will be limited.

6.7 Traffic Noise and Vibration

Due to the location of the subject site, its accessibility via major regional road, significant passing trade component, the traffic impact from the development in the area will be limited.

It generally requires a doubling of traffic volumes on a road to produce a perceptible 3dB(A) increase in road noise. The proposed development will not increase traffic volumes or noise on surrounding roads anywhere near this level.

7 Parking

The parking supply and demand for the proposed neighbourhood centre is summarised in **Table 4**.

Table 4: Car parking assessment

Use	Required	Provided	Surplus / Shortfall (+/-)
Supermarket	70	50	-20
Specialty shops	16	5	-11
Fast Food outlets	49	46	-3
Service station	22	15	-7
Liquor store	18	27	+9
On-street bays		4	+4
Total theoretical shortfall considering the on-street bays			-28

The total parking requirement based on relevant City's scheme requirement is estimated to be 175 bays and the total parking supply including the on-street parking is 147 bays and therefore, there is a theoretical 28-car bay shortfall for the proposed neighbourhood centre site.

As the peak parking demand periods for the various land-uses within the subject site do not completely overlap, a daily parking demand profile was developed for each of the proposed land-uses to estimate the combined parking demand throughout the day (for a typical Friday and a typical Saturday).

The percentage of parking demand assumptions outlined in **Table 5** (for a typical Friday) and **Table 7** (for a typical Saturday) are conservative to result in a robust assessment and outcome.

The anticipated demand for car parking is then calculated by multiplying the anticipated percentage of parking demand for each land-use by its theoretical parking requirement. The estimated number of parking bays required are summarised in **Table 6** (for a typical Friday) and **Table 8** (for a typical Saturday). The parking surplus (+)/shortfall (-) for each land-use and time period is estimated by subtracting the total anticipated parking demand from the proposed number of bays provided (147 bays).

Table 5: Percentage of parking demand temporal analysis – typical Friday

TIME	Estimated Percentage of Parking Demand - Typical Friday					
	Liquor	Supermarket	Fast Food	Specialty	Service station	
6:00	0%	10%	10%	10%	50%	
7:00	0%	20%	10%	20%	70%	
8:00	10%	30%	40%	30%	100%	
9:00	10%	40%	50%	40%	70%	
10:00	20%	50%	70%	50%	60%	
11:00	30%	70%	80%	70%	40%	
12:00	30%	80%	80%	90%	40%	
13:00	30%	80%	90%	80%	50%	
14:00	30%	70%	80%	70%	50%	
15:00	30%	60%	70%	60%	60%	
16:00	50%	70%	60%	70%	70%	
17:00	60%	80%	50%	70%	100%	
18:00	80%	80%	70%	70%	80%	
19:00	80%	60%	90%	70%	50%	
20:00	50%	40%	50%	50%	40%	
21:00	40%	10%	50%	10%	30%	
Requirements based on TPS	18	70	49	16	22	175
Provided	27	50	46	5	15	147
surplus / shortfall (+/-)	9	-20	-3	-11	-7	-28

including on-street



Table 6: Parking demand temporal analysis – typical Friday

TIME	Estimated Number of Parking Bays Required - Typical Friday						Onsite Parking Surplus/Shortfall (150 - Total)
	Liquor	Supermarket	Fast Food	Specialty	Service station	Total	
6:00	0	7	5	2	11	25	123
7:00	0	14	5	3	15	38	110
8:00	2	21	20	5	22	69	78
9:00	2	28	25	6	15	76	71
10:00	4	35	34	8	13	94	53
11:00	5	49	39	11	9	114	33
12:00	5	56	39	14	9	124	23
13:00	5	56	44	13	11	129	18
14:00	5	49	39	11	11	116	31
15:00	5	42	34	10	13	105	43
16:00	9	49	29	11	15	114	33
17:00	11	56	25	11	22	125	23
18:00	14	56	34	11	18	134	14
19:00	14	42	44	11	11	123	24
20:00	9	28	25	8	9	78	69
21:00	7	7	25	2	7	47	100



As detailed in **Table 6**, the maximum combined parking demand for a typical Friday is anticipated to occur at 18:00PM. During this period, it is estimated that a surplus of 14 bays would be available within the proposed development.

Similarly, As detailed in **Table 8**, the maximum combined parking demand for a typical Saturday is anticipated to occur at 11.00PM. During this period, it is estimated that a surplus of three bays would be available.

On this basis, considering that the peak parking demand of the respective land uses within the proposed neighbourhood centre is different, reciprocal parking can be considered. The parking assessment undertaken indicates that there would be surplus parking available during the weekday and weekends and therefore the proposed parking supply is sufficient to address the parking requirements of the proposed development. Further, for assessment of parking supply and demand consideration should be given to the following:

- ✚ Variance of peak times between various land uses;
- ✚ Multi-use trips generated by the co-location of complementary land uses; and,
- ✚ Walkability of the area.

Table 7: Percentage of Parking demand temporal analysis – typical Saturday

TIME	Estimated Percentage of Parking Demand - Typical Saturday					
	Liquor	Supermarket	Fast Food	Specialty	Service station	
6:00	0%	10%	10%	10%	50%	
7:00	0%	20%	10%	20%	70%	
8:00	10%	30%	40%	30%	100%	
9:00	10%	40%	50%	40%	70%	
10:00	20%	50%	80%	60%	60%	
11:00	30%	100%	90%	100%	40%	
12:00	30%	90%	100%	90%	40%	
13:00	40%	90%	90%	80%	50%	
14:00	40%	80%	80%	70%	50%	
15:00	40%	70%	70%	60%	60%	
16:00	50%	70%	60%	70%	70%	
17:00	80%	70%	50%	70%	100%	
18:00	100%	50%	90%	50%	80%	
19:00	100%	20%	90%	20%	50%	
20:00	70%	20%	50%	20%	40%	
21:00	50%	10%	50%	10%	30%	
Requirements based on TPS	18	70	49	16	22	175

Provided
surplus / shortfall (+/-)

27
9

50
-20

46
-3

5
-11

15
-7

147
-28

including on-stree



Table 8: Parking demand temporal analysis – typical Saturday

TIME	Estimated Number of Parking Bays Required - Typical Saturday						Onsite Parking Surplus/Shortfall (150 - Total)
	Liquor	Supermarket	Fast Food	Specialty	Service station	Total	
6:00	0	7	5	2	11	25	123
7:00	0	14	5	3	15	38	110
8:00	2	21	20	5	22	69	78
9:00	2	28	25	6	15	76	71
10:00	4	35	39	10	13	101	46
11:00	5	70	44	16	9	144	3
12:00	5	63	49	14	9	141	6
13:00	7	63	44	13	11	138	9
14:00	7	56	39	11	11	125	22
15:00	7	49	34	10	13	113	34
16:00	9	49	29	11	15	114	33
17:00	14	49	25	11	22	121	26
18:00	18	35	44	8	18	123	24
19:00	18	14	44	3	11	90	57
20:00	13	14	25	3	9	63	84
21:00	9	7	25	2	7	49	98



8 Provision of Heavy Vehicles

The largest fuel tanker and a service vehicle which are expected to use the subject site are 19m fuel tankers and 12.5m service trucks.

19m fuel tanker

Turn path analysis has been undertaken for a 19m fuel tanker to enter the site from Thundelarra Drive full movement crossover, access the refuelling point and exit the site and turn left onto Aurea Blvd in forward gear. Mountable kerb/painted area has been provided at Aurea Blvd crossover to facilitate the left turn exit movement of fuel tankers.

service trucks

12.5m service trucks are expected to service the proposed supermarket. The service truck for the supermarket would enter the site from Wyloo Lane crossover and would exit the site via the proposed left in/ left out crossover on Aurea Blvd.

8.8m service trucks are expected to service the proposed service station. The service truck would enter the site from Thundelarra Drive full movement crossover and exit via the proposed left in/ left out crossover on Aurea Blvd.

The largest service truck that would service the proposed fast-food outlets is an 8.8m rigid truck. The service truck would enter the site from Thundelarra Drive full movement crossover and exit via the proposed left in/ left out crossover on Aurea Blvd.

The largest truck that can service the proposed liquor store is an 8.8m rigid truck which would enter and exit the site via Wyloo Lane crossover.

The service vehicles would attend the site outside the peak periods to minimise the internal and external impact.

Turn path analysis undertaken for fuel tanker and service vehicles confirm satisfactory access, egress and circulation. The turn path analysis plans are included in **Appendix D**.

Turn path plan demonstrate that the tanker will require to use almost the full width of Thundelarra Drive southern crossover to access the site. As the fuel tanker is expected to access the site about twice per week and outside peak operating conditions, traversing almost the full width of the crossover is acceptable in accordance with the relevant Australian Standard.

9 Conclusions

This Revised TIA has been prepared by Transcore on behalf of Ladybug Twenty Pty Ltd with regards to the proposed Golden Bay Neighbourhood Centre to be located at 2 Aurea Boulevard, Golden Bay.

The proposed development would utilise the existing crossover on Thundelarra Drive and is providing a left in/ left out crossover on Aurea Blvd and a connection to Wyloo Lane.

The net addition of traffic as a result of the proposed development when accounting for passing trade is **+125vph** (AM peak hour) and **+220vph** (PM peak hour) on the surrounding road network.

The stacking capacity of the proposed fast-food outlets satisfy the RTA Guidelines requirements.

Queue analysis undertaken for the proposed service station indicated that under typical “cheap fuel day” peak conditions the queuing associated with the service station will be accommodated within the site without impacting the internal driveways and development crossovers.

Network SIDRA models were developed to assess the development crossovers on Thundelarra Drive and Aurea Blvd and nearby intersections as an integrated traffic network. The analysis result indicates satisfactory traffic operations of the intersections and the crossovers.

Total of 147 bays including four on-street bays and eight ACROD Bays are proposed for the proposed neighbourhood centre which represents theoretical parking shortfall of about 28 bays. Considering that the peak parking demand of the respective land uses within the proposed neighbourhood centre is different, reciprocal parking can be considered. The parking assessment undertaken in this report indicates that there would be surplus parking available on site during the weekday and weekend peak periods and therefore the proposed parking supply is sufficient to address the parking requirements of the proposed development.

In conclusion, the findings of this Transport Impact Assessment are supportive of the proposed development.

Appendix A

TRANSCORE RESPONSES TO CITY'S COMMENTS

DEVELOPMENT
ASSESSMENT PANEL

APPROVED
12-Mar-2024

Golden Bay Neighbourhood Centre | CITY OF ROCKINGHAM COMMENTS

02 May 2023

Note: responses in green are addressed in the revised TIA.

	CITY COMMENTS	STATUS/COMMENT
1	<p>Concerns over the proposed left-in, left-out off Aurea Boulevard and its proximity to the Warnbro Sound Avenue intersection – awaiting MRWA comments.</p> <p>Impact on the performance of surrounding intersections and increased traffic safety risks</p> <p>The stop line distance between the signalised intersection (Warnbro Sound Avenue/Aurea Boulevard/Adelong Avenue) and the roundabout (Aurea Boulevard/Thundelarra Drive) is approximately 95m which is considered too short to have an access located between the intersections. LDI is concerned that the introduction of an access off Aurea Boulevard would significantly impact the performance of the two existing intersections (queues from the traffic signal may block access to the site, queues from the proposed access may impact on the adjacent roundabout intersections, very short distance if needing to turn right into Warnbro Sound Avenue from the proposed crossover, etc.) as well as increases traffic safety risks. It should be noted that the Transport Assessment for the Golden Bay Comprehensive Development Plan estimates a daily traffic volume of 9,400 and 5,000 for Aurea Boulevard and Thundelarra Drive respectively therefore an access off Thundelarra is recommended in order to minimise traffic safety risks.</p>	<p>The crossover is a left in/ left out only and would be located before the 70-degree left turn slip lane on Aurea Blvd. Also, this crossover is important for effective and efficient circulation system for the development and in particular the land uses closest to the Aurea Boulevard.</p> <p>The SIDRA network analysis undertaken indicates no queue back from the signalised intersection or back to the roundabout intersection to the proposed left in/ left out crossover (refer Figures 15 and 16 of the TIA). The crossover also operates with good LOS during the AM and PM peak hours. Therefore, the provision of the proposed left in/ left out crossover would not undermine traffic operations in the immediate locality.</p> <p>The traffic projections for the Golden Bay Comprehensive Development Plan Update (prepared by Transcore, dated 1st April 2011) reflects the full development of the Golden Bay by year 2031. It is our understanding that it is unlikely that the Golden Bay Development Plan and the surrounding areas would be fully developed by year 2031 and the projected traffic volumes on Aurea Blvd and Thundelarra Drive would reach to the level that was reported for the full development of the Golden Bay Structure Plan. As a result, Transcore adopted the methodology of 2% annual growth on the existing traffic volumes. According to the Golden Bay Comprehensive Development Plan Update (prepared by Transcore, dated 1st April 2011) Aurea Boulevard (between Warnbro Sound Avenue and Thundelarra Drive) is classified as “Integrator B”. The intersection spacing on an “Integrator B” is recommended</p>

<p>Insufficient separation distance between intersections to accommodate an access</p> <ul style="list-style-type: none"> • Austroads' Guide to Road Design Part 4 – Intersections and Crossings – General recommends a minimum access spacing of 55m (based on "Stopping Sight Distance"). This suggests that the existing distance between the stop lines of the existing intersection should be at least 110m therefore an access is unlikely able to be located between the roundabout and traffic signal. • The proposed vehicle crossover is located within the functional area of the traffic signal as well as the eastern wing is encroaching into the left turning slip lane. <p>Queue from the traffic signal impacting on the access</p> <ul style="list-style-type: none"> • There is a concern that with heavy traffic expected on Aurea Boulevard (i.e. 9,400vpd), the vehicle queue length for the western approach to the traffic signal is likely to impact on the proposed access. • The Golden Bay Village Centre – Revised Development Application Transport Impact Assessment – Addendum (Lot 622 Thundelarra Drive, prepared by Uloth dated 16th March 2018) had completed an intersection analysis for the traffic signal at Warnbro Sound Avenue/Aurea Boulevard/Adelong Avenue and the results suggest an expected queue length of 122m for the western approach. <p>The Transport Assessment for the existing child care (Lot 716 Aurea Boulevard, prepared by Cardo, dated 1st March 2017) suggests an expected queue length of 49.4m for the western approach.</p> <p>The distance between the stop line for the traffic signal to the centre of the proposed access is approximately 45m. This suggests</p>	<p>as 40m in accordance with LN Guidelines. Therefore, there is sufficient separation distance between the intersections. The LN or any other guidelines do not prohibit crossovers within this separation.</p> <p>The Austroads Guidelines Part 4 does provide guidelines on stopping sight distance however, the stopping distance is measured on a straight section of road and not on sections intersected by intersections which is the case here. Further, although Austroads and Liveable Neighbourhoods provide guidelines for intersection spacing, they do not prohibit provision of crossovers within that spacing.</p> <p>The location of the crossover with respect to an intersection is addressed in Australian Standards 2890.1. Section 3.2.3 and Figure 3.1 of the Standard provides guidelines on prohibited location of access driveways with respect to an intersection. Basically, an access driveway should be located at least 6m from the corner truncation of an intersection. The Aurea Boulevard crossover satisfies this requirement for both intersections at both ends of this road.</p> <p>The proposed left in/ left out crossover is located before the existing left turn slip lane at Aurea Blvd and therefore it is not located within the effective functional area of the traffic signal. A mountable apron is suggested for the exit of the trucks at this crossover. This apron ties into the proposed left turn slip lane at the signalised intersection.</p> <p>The traffic report by U&A and Cardno are now 5 and 6 years old. The SIDRA analysis results and site observations undertaken by Transcore in 2023 indicate that the existing signalised and roundabout intersections presently operate satisfactorily (overall LoS C for signalised intersection and LoS A for roundabout intersection) with moderate queues and delays during both weekday peak hours for the signalised intersection and no queues and delays at the roundabout intersection. The SIDRA assessment for the 10-year post development scenario during the nominated peak periods rendered similar</p>
--	---

	<p>that the queue from the traffic signal is likely to impact on the proposed access.</p> <p>Neighbourhood Centre Detailed Area Plan</p> <p>The approved plan suggests that no access is to be provided off Aurea Boulevard and Warnbro Sound Avenue</p>	<p>results to post-development scenario with marginal increases in delays and queues and no changes to the Level of Service for any of the movements of the intersections. Importantly, both intersections retain ample spare capacity for future traffic growth. For the 10-year post development analysis a 2% annual traffic growth was applied to the background traffic. The 2% annual growth reflects the current conditions. It is not clear what traffic projections has been used by Uloth and Cardno for preparation of the traffic reports prepared by these two consultants.</p> <p>The Golden Bay Neighbourhood Centre Detailed Area Plan is a guide for future development of the proposed neighbourhood centre. The DAP does not show any crossover on Aurea Blvd to the other side of the development however a left in/ left out crossover was approved and constructed on the other side of Aurea Boulevard for a similar development opposite the subject development. This constructed crossover has been operating with now traffic issues.</p>
2	<p>Removal of the two on-street bays on Aurea Boulevard due to restricted sight lines at the vehicle crossover.</p>	<p>The two on-street bays on Aurea Boulevard have been removed in the updated development plan.</p>
3	<p>Concerns that queuing from the service station will spill out onto public roads, with additional queuing required – only 1 vehicle can be accommodated behind the bowser where a minimum of 2 should be provided for. Vehicles are able to come into the bowser from other directions which is likely to reduce the efficiency of the restricted queuing space and the potential to block internal traffic flow, increasing risk that vehicle queuing from the service station may overflow onto public street</p>	<p>The stacking capacity of the proposed service station have been assessed in the TIA. The outcome of the queue length analysis indicates that during a busy day the 95th percentile queue within the proposed service station is 12 cars (8 cars refuelling and 4 cars waiting). The service station layout can comfortably accommodate this level of queuing.</p> <p>In order to investigate if four additional cars park behind four fill points, still a B99 car can navigate the site, Figure 4 in the revised TIA is prepared. This sketch shows that at worst case scenario that 2 cars park at both sides of the last two bowzers, still a B99 car can move around the parked cars.</p>

4	Confusing arrangements regarding the hatched area for the service station due to location and geometry of bower location – kerbing may be required.	The line marked kerb should be sufficient, however mountable kerb can also be provided if needs be. This is a design issue and can be addressed during the detailed design stage of the project.
5	The proposed HRV loading bay for the service station does not conform to AS2890.2. Confirmation is required in the TIA that the maximum commercial vehicle servicing the supermarket is a 12.5m HRV. Swept path analysis is required to demonstrate that it is possible to enter and exit the site in forward gear (without encroaching into the area where vehicles queue for the bowser, as well as no reversing movement along the parking aisle.	The proposed loading bay in the updated plan has been adjusted to conform to AS2890.2. An 8.8m truck is expected to service the loading bay. The updated turn paths indicates that an 8.8m truck can enter and exit the site in forward gear satisfactorily. The service trucks are expected to attend the site after hours to minimis the traffic conflict at the site. This type of operations is not unusual for service stations.
6	Provision for cars to turn around at the end of the blind aisle(s) near the liquor store, and drive out forward to be provided in accordance with AS2890.2	The provision of a turnaround bay is not required because the length of the blind isle is less than six 90-degree bays plus 1m as suggested by AS2890.1. Please note that the proposed liquor store drive through would also facilitate the turnaround for cars that enter the blind isle.
7	Advise how were differences in turning volumes sourced by using SCAT and video survey in determining the existing turning volumes for the two intersections	The video turning movement counts were undertaken for the existing roundabout intersection. The SCATS data was sourced for the signalised intersection. The video counts indicated slightly higher traffic volumes on Aurea Blvd. Therefore, the SCATS traffic data were factored up to match the outcome of the video traffic counts on Aurea Blvd, resulting in a robust assessment.
8	References used for trip generation rates, passing trade and directional split are required to be provided in an extract to verify validity	Transcore referenced ITE guidelines for trip rates. The City trip generation assessments provided to Transcore also used the same guideline and provide almost similar results to Transcore assessments when applying no cross trade to the trips (refer below table). As evident Transcore’s trip generation estimation for critical PM peak hour is higher than CoR and also DPLH (DPLH estimate is 503 trips during the PM peak hour). However, Transcore applied 25% cross trade in line with RTA NSW Guidelines to allow for internal trips between different land uses.

			AM trips Transcore	AM trips COR	PM trips Transcore	PM trips COR
		Fast food outlet with drive through	227	227	185	185
		Liquor	0	0	41	41
		Supermarket	19	48	186	116
		Specialty	1	19	11	8
		Service Station	100	100	112	112
		Total	347	394	534	462
9	The reference for assuming 25% cross-trade is required	The RTA NSW Guidelines indicates a discount rate of 25% for centres less than 10,000 m2 GLFA.				
10	Trip distribution is to be shown on a plan – query why only small amount of traffic is associated with Warnbro Sound Avenue?	Figure 11 of the TIA shows the proposed development traffic for the AM and PM Weekday peak hours. According to this plan about 25% of the total trips have been distributed to the traffic signal and the balance have been distributed to the west of the Warnbro Sound Avenue. As the proposed centre is located to the west of Warnbro Sound Avenue, it is expected that mainly residents to the west of Warnbro Sound Avenue would access the site via Thundelarra Drive and Aurea Blvd.				
11	Plan showing passing and non-passing trade is required	The Figure 11 of the TIA is the summation of the passing and non-passing trip distribution and is sufficient for the purpose of TIA.				
12	Number of vehicle trips entering and exiting the site does not appear to match with the external road links as shown in Figure 11	It matches. See below calculations extracted from Figure 11 of the TIA. It should be noted that passing trips already exists on the roads and would only appear at development crossovers. AM inbound = 35 + 95 = 130 PM inbound = 55 + 144 = 199 AM outbound = 96 + 34 = 130 PM outbound = 55 + 144 = 199				

13	Validity of traffic assessment is queried (i.e. estimated daily traffic volumes are significantly different when compared with the approved Structure Plan for Golden Bay	The traffic projections for the Golden Bay Comprehensive Development Plan Update (prepared by Transcore, dated 1st April 2011) reflects the full development of the Golden Bay by year 2031. It is our understanding that it is unlikely that the Golden Bay Development Plan and the surrounding areas would be fully developed by year 2031 and the projected traffic volumes on Aurea Blvd and Thundelarra Drive would reach to the level that was reported for the full development of the Golden Bay Structure Plan. As a result, Transcore adopted the methodology of 2% annual growth on the existing traffic volumes. This approach was accepted as part of the approved and constructed development opposite the subject site on the other side of Aurea Boulevard.
14	Confirm whether SIDRA models been calibrated to match existing conditions	Yes, the SIDRA models were calibrated against the existing queues at the signalised and roundabout intersections. The outcome of the existing assessments is provided in Appendix B of the TIA.
15	Kerb ramps for universal access across site	The updated plan shows the Kerb ramps for universal access
16	Pedestrian refuge within Thundelarra crossover to be shown	The fuel tanker needs to full width of the crossover to turn in. Therefore, provision of a refuge may not be feasible. Also, review of the Nearmap images indicates that there are no refuges at any of the t-intersections or crossovers in this area. Therefore, the pedestrian refuge at Thundelarra crossover is not required. In any case, the updated development plan shows the crossover with red paving to indicate pedestrian priority at the crossover.
17	Relocation of bicycle parking so as not to restrict pedestrian flow	The proposed bicycle parking does not restrict pedestrian flow
18	Concerns regarding swept path analysis: <ul style="list-style-type: none"> o Encroaching into the opposing traffic lane o Clash with kerbing o Insufficient horizontal clearance to the kerb ramp o Reversing movement 	<ol style="list-style-type: none"> 1. The body of the fuel tanker or 12.5m truck would not encroach onto the right turn lane on Aurea Blvd when exiting the proposed LiLo crossover. 2. The body of the vehicle would not clash with the kerbs; 3. The clearance maybe insufficient at some kerbs but the body of the truck would not clash with the kerbs. 4. the 12.5m truck reverse back to the supermarket loading bay for a short distance which would not undermine traffic operations or safety.

		It should be noted that service vehicles will visit the site infrequently and generally outside the peak operating times when the traffic on surrounding roads are lower and less activity is happening within the development.
19	An independent trip generation exercise found that results are significantly different, especially during the AM peak hour (i.e. the City's generation volume is 52% more).	The 25% relates to the cross-trade which was assumed in Transcore calculations. Refer response to item 8 above.
20	The total number of trips entering and exiting does not appear to match with the external road links	Refer response to item 12 above.
21	Section 6.5 suggests that the proposed development will not increase traffic on any lanes by more than 100 vph however Figure 11 clearly suggests that some traffic lanes increase by more than 100 vph which suggests contradictory	The increase of just over 100vph per lane would happen during the PM peak hour for a short section of Thundelarra Dr between the roundabout and the development crossover which would result in total traffic projection of about 245vph or 2450vpd during the PM peak hour in 2033. The current standard of Thundelarra Dr as a neighbourhood connector B road would be able to comfortably accommodate the 2033 projected traffic volumes along this section of the road.

Appendix B

PROPOSED DEVELOPMENT PLAN

DEVELOPMENT
ASSESSMENT PANEL

APPROVED

12-Mar-2024

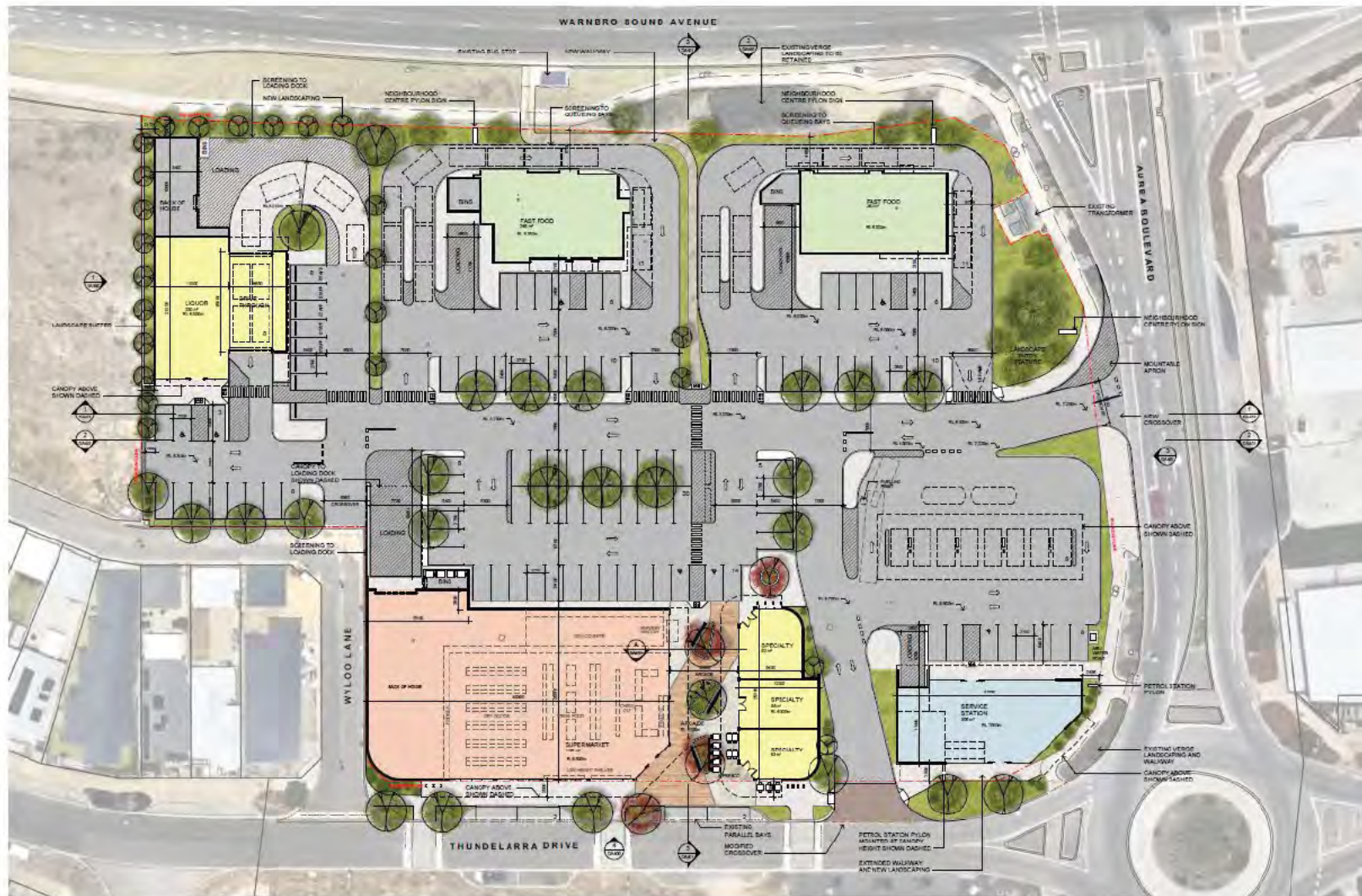

PROPOSED GROUND FLOOR PLAN
GOLDEN BAY NEIGHBOURHOOD CENTRE

Status: **DEVELOPMENT APPLICATION**
Path: City of Jarra Jarra Development Application 44634 - Golden Bay Neighbourhood Centre, L1/Arch

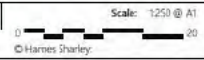

Project Number: 44634
Drawing Number: DA200
Revision: K
Date: 28.04.23



**DEVELOPMENT
ASSESSMENT PANEL**

APPROVED

12-Mar-2024

Appendix C

INTERSECTION ANALYSIS – SIDRA RESULTS

DEVELOPMENT
ASSESSMENT PANEL

APPROVED
22-Mar-2024

MOVEMENT SUMMARY

Site: [Thundelarra Dr & Aurea Blvd - Existing - AM (Site Folder: Existing)]

Network: N102 [AM (Network Folder: Existing)]

Site Category: (None)
Roundabout

Vehicle Movement Performance														
Mov ID	Turn	DEMAND FLOWS		ARRIVAL FLOWS		Deg. Satn	Aver. Delay	Level of Service	95% BACK OF QUEUE		Prop. Que	Effective Stop Rate	Aver. No. Cycles	Aver. Speed
		[Total veh/h]	[HV %]	[Total veh/h]	[HV %]				[Veh. veh]	[Dist m]				
South: Thundelarra Dr (S)														
1	L2	6	4.0	6	4.0	0.130	3.1	LOS A	0.8	6.6	0.29	0.55	0.29	41.5
2	T1	13	4.0	13	4.0	0.130	3.0	LOS A	0.8	6.6	0.29	0.55	0.29	39.2
3	R2	139	4.0	139	4.0	0.130	7.7	LOS A	0.8	6.6	0.29	0.55	0.29	25.5
3u	U	3	4.0	3	4.0	0.130	9.6	LOS A	0.8	6.6	0.29	0.55	0.29	28.5
Approach		161	4.0	161	4.0	0.130	7.2	LOS A	0.8	6.6	0.29	0.55	0.29	28.9
East: Aurea Blvd (E)														
4	L2	91	4.0	91	4.0	0.131	3.0	LOS A	0.7	5.1	0.16	0.36	0.16	37.7
5	T1	82	4.0	82	4.0	0.131	2.9	LOS A	0.7	5.1	0.16	0.36	0.16	47.9
6	R2	1	4.0	1	4.0	0.131	7.7	LOS A	0.7	5.1	0.16	0.36	0.16	46.4
6u	U	1	4.0	1	4.0	0.131	9.5	LOS A	0.7	5.1	0.16	0.36	0.16	36.2
Approach		175	4.0	175	4.0	0.131	3.0	LOS A	0.7	5.1	0.16	0.36	0.16	44.6
North: Thundelarra Dr (N)														
7	L2	3	4.0	3	4.0	0.024	4.2	LOS A	0.1	1.0	0.45	0.46	0.45	38.0
8	T1	17	4.0	17	4.0	0.024	4.1	LOS A	0.1	1.0	0.45	0.46	0.45	39.2
9	R2	3	4.0	3	4.0	0.024	8.9	LOS A	0.1	1.0	0.45	0.46	0.45	46.4
9u	U	1	4.0	1	4.0	0.024	10.7	LOS B	0.1	1.0	0.45	0.46	0.45	46.3
Approach		24	4.0	24	4.0	0.024	5.0	LOS A	0.1	1.0	0.45	0.46	0.45	41.0
West: Aurea Blvd (W)														
10	L2	1	4.0	1	4.0	0.103	3.7	LOS A	0.6	4.7	0.38	0.46	0.38	44.3
11	T1	88	4.0	88	4.0	0.103	3.6	LOS A	0.6	4.7	0.38	0.46	0.38	42.7
12	R2	18	4.0	18	4.0	0.103	8.4	LOS A	0.6	4.7	0.38	0.46	0.38	41.8
12u	U	8	4.0	8	4.0	0.103	10.2	LOS B	0.6	4.7	0.38	0.46	0.38	48.3
Approach		116	4.0	116	4.0	0.103	4.8	LOS A	0.6	4.7	0.38	0.46	0.38	43.2
All Vehicles		476	4.0	476	4.0	0.131	5.0	LOS A	0.8	6.6	0.27	0.45	0.27	40.5



DEVELOPMENT
ASSESSMENT PANEL

APPROVED
22-Mar-2024

MOVEMENT SUMMARY

Site: [Warnbro sound Ave & Aurea Blvd & Adelong Ave - Existing - AM (Site Folder: Existing)]

Network: N102 [AM (Network Folder: Existing)]

Site Category: (None)

Signals - EQUISAT (Fixed-Time/SCATS) Isolated Cycle Time = 101 seconds (Site User-Given Phase Times)

Vehicle Movement Performance														
Mov ID	Turn	DEMAND FLOWS		ARRIVAL FLOWS		Deg. Satn v/c	Aver. Delay sec	Level of Service	95% BACK OF QUEUE		Prop. Que	Effective Stop Rate	Aver. No. Cycles	Aver. Speed km/h
		[Total veh/h]	[HV %]	[Total veh/h]	[HV %]				[Veh. veh]	[Dist m]				
South: Wambro Sound Ave (S)														
1	L2	44	4.0	44	4.0	0.031	6.5	LOS A	0.2	1.9	0.18	0.59	0.18	49.7
2	T1	241	5.8	241	5.8	0.276	34.2	LOS C	4.9	38.3	0.86	0.69	0.86	33.2
3	R2	7	4.0	7	4.0	0.047	52.3	LOS D	0.3	2.7	0.94	0.66	0.94	24.5
Approach		293	5.5	293	5.5	0.276	30.4	LOS C	4.9	38.3	0.76	0.67	0.76	34.2
East: Adelong Ave(E)														
4	L2	16	4.0	16	4.0	0.178	26.2	LOS C	2.3	18.0	0.83	0.66	0.83	35.4
5	T1	60	4.0	60	4.0	*0.178	21.6	LOS C	2.3	18.0	0.83	0.66	0.83	15.2
6	R2	24	4.0	24	4.0	0.064	38.4	LOS D	0.9	7.4	0.82	0.69	0.82	19.0
Approach		100	4.0	100	4.0	0.178	26.4	LOS C	2.3	18.0	0.83	0.67	0.83	21.1
North: Warnbro Sound Ave (N)														
7	L2	23	4.0	23	4.0	0.022	12.4	LOS B	0.4	3.2	0.42	0.62	0.42	35.1
8	T1	369	9.8	369	9.8	*0.440	35.8	LOS D	7.9	64.1	0.90	0.74	0.90	32.4
9	R2	72	4.0	72	4.0	*0.460	55.4	LOS E	3.5	27.7	0.99	0.76	0.99	10.9
Approach		464	8.6	464	8.6	0.460	37.7	LOS D	7.9	64.1	0.89	0.74	0.89	29.5
West: Aurea Blvd (W)														
10	L2	137	4.0	137	4.0	0.191	10.3	LOS B	2.8	22.0	0.48	0.60	0.48	36.8
11	T1	47	4.0	47	4.0	*0.191	5.7	LOS A	2.8	22.0	0.48	0.60	0.48	32.8
12	R2	47	4.0	47	4.0	0.125	39.1	LOS D	1.9	14.8	0.84	0.72	0.84	27.8
Approach		232	4.0	232	4.0	0.191	15.2	LOS B	2.8	22.0	0.56	0.62	0.56	32.6
All Vehicles		1088	6.4	1088	6.4	0.460	29.9	LOS C	7.9	64.1	0.78	0.69	0.78	30.8



DEVELOPMENT
ASSESSMENT PANEL

APPROVED
22-Mar-2024

MOVEMENT SUMMARY

Site: [Thundelarra Dr & Aurea Blvd - Existing - PM (Site Folder: Existing)]

Network: N102 [PM (Network Folder: Existing)]

Site Category: (None)
Roundabout

Vehicle Movement Performance														
Mov ID	Turn	DEMAND FLOWS		ARRIVAL FLOWS		Deg. Satn	Aver. Delay	Level of Service	95% BACK OF QUEUE		Prop. Que	Effective Stop Rate	Aver. No. Cycles	Aver. Speed
		[Total veh/h]	[HV %]	[Total veh/h]	[HV %]				[Veh. veh]	[Dist m]				
South: Thundelarra Dr (S)														
1	L2	6	4.0	6	4.0	0.067	3.3	LOS A	0.4	3.2	0.34	0.55	0.34	41.5
2	T1	5	4.0	5	4.0	0.067	3.2	LOS A	0.4	3.2	0.34	0.55	0.34	39.2
3	R2	65	4.0	65	4.0	0.067	7.9	LOS A	0.4	3.2	0.34	0.55	0.34	25.3
3u	U	1	4.0	1	4.0	0.067	9.8	LOS A	0.4	3.2	0.34	0.55	0.34	28.4
Approach		78	4.0	78	4.0	0.067	7.3	LOS A	0.4	3.2	0.34	0.55	0.34	30.0
East: Aurea Blvd(E)														
4	L2	64	4.0	64	4.0	0.139	2.9	LOS A	0.7	5.6	0.13	0.34	0.13	38.2
5	T1	128	4.0	128	4.0	0.139	2.7	LOS A	0.7	5.6	0.13	0.34	0.13	48.1
6	R2	2	4.0	2	4.0	0.139	7.5	LOS A	0.7	5.6	0.13	0.34	0.13	46.6
6u	U	1	4.0	1	4.0	0.139	9.4	LOS A	0.7	5.6	0.13	0.34	0.13	36.9
Approach		196	4.0	196	4.0	0.139	2.9	LOS A	0.7	5.6	0.13	0.34	0.13	46.3
North: Thundelarra Dr (N)														
7	L2	1	4.0	1	4.0	0.021	3.6	LOS A	0.1	0.9	0.36	0.45	0.36	38.1
8	T1	15	4.0	15	4.0	0.021	3.5	LOS A	0.1	0.9	0.36	0.45	0.36	39.2
9	R2	6	4.0	6	4.0	0.021	8.3	LOS A	0.1	0.9	0.36	0.45	0.36	46.3
9u	U	1	4.0	1	4.0	0.021	10.1	LOS B	0.1	0.9	0.36	0.45	0.36	46.2
Approach		23	4.0	23	4.0	0.021	5.1	LOS A	0.1	0.9	0.36	0.45	0.36	42.4
West: Aurea Blvd (W)														
10	L2	1	4.0	1	4.0	0.079	3.2	LOS A	0.5	3.6	0.26	0.36	0.26	45.3
11	T1	86	4.0	86	4.0	0.079	3.0	LOS A	0.5	3.6	0.26	0.36	0.26	44.1
12	R2	7	4.0	7	4.0	0.079	7.8	LOS A	0.5	3.6	0.26	0.36	0.26	43.0
12u	U	2	4.0	2	4.0	0.079	9.7	LOS A	0.5	3.6	0.26	0.36	0.26	49.2
Approach		97	4.0	97	4.0	0.079	3.5	LOS A	0.5	3.6	0.26	0.36	0.26	44.2
All Vehicles		394	4.0	394	4.0	0.139	4.0	LOS A	0.7	5.6	0.21	0.39	0.21	43.5



DEVELOPMENT
ASSESSMENT PANEL

APPROVED
22-Mar-2024

MOVEMENT SUMMARY

Site: [Warnbro sound Ave & Aurea Blvd & Adelong Ave - Existing - PM (Site Folder: Existing)]

Network: N102 [PM (Network Folder: Existing)]

Site Category: (None)

Signals - EQUISAT (Fixed-Time/SCATS) Isolated Cycle Time = 104 seconds (Site User-Given Phase Times)

Vehicle Movement Performance														
Mov ID	Turn	DEMAND FLOWS		ARRIVAL FLOWS		Deg. Satn	Aver. Delay	Level of Service	95% BACK OF QUEUE		Prop. Que	Effective Stop Rate	Aver. No. Cycles	Aver. Speed
		[Total veh/h]	[HV %]	[Total veh/h]	[HV %]				[Veh. veh]	[Dist m]				
South: Warnbro Sound Ave (S)														
1	L2	67	4.0	67	4.0	0.049	6.6	LOS A	0.4	3.1	0.19	0.59	0.19	49.5
2	T1	363	5.8	363	5.8	*0.429	37.2	LOS D	8.0	62.4	0.90	0.74	0.90	31.9
3	R2	5	4.0	5	4.0	0.026	50.2	LOS D	0.2	1.9	0.91	0.65	0.91	25.1
Approach		436	5.5	436	5.5	0.429	32.7	LOS C	8.0	62.4	0.79	0.72	0.79	33.2
East: Adelong Ave(E)														
4	L2	6	4.0	6	4.0	0.052	26.7	LOS C	0.7	5.4	0.79	0.60	0.79	34.9
5	T1	16	4.0	16	4.0	0.052	22.2	LOS C	0.7	5.4	0.79	0.60	0.79	14.7
6	R2	26	4.0	26	4.0	*0.071	40.1	LOS D	1.1	8.4	0.83	0.70	0.83	18.5
Approach		48	4.0	48	4.0	0.071	32.5	LOS C	1.1	8.4	0.81	0.65	0.81	20.4
North: Warnbro Sound Ave (N)														
7	L2	37	4.0	37	4.0	0.034	12.2	LOS B	0.6	5.0	0.41	0.63	0.41	35.3
8	T1	319	9.8	319	9.8	0.391	36.9	LOS D	6.9	56.5	0.89	0.73	0.89	32.0
9	R2	112	4.0	112	4.0	*0.554	54.6	LOS D	5.6	43.7	0.99	0.79	0.99	11.1
Approach		467	8.0	467	8.0	0.554	39.2	LOS D	6.9	56.5	0.88	0.74	0.88	27.5
West: Aurea Blvd (W)														
10	L2	116	4.0	116	4.0	0.098	6.1	LOS A	1.1	8.4	0.23	0.54	0.23	41.1
11	T1	11	4.0	11	4.0	*0.098	1.6	LOS A	1.1	8.4	0.23	0.54	0.23	37.4
12	R2	26	4.0	26	4.0	0.071	40.1	LOS D	1.1	8.4	0.83	0.70	0.83	27.5
Approach		153	4.0	153	4.0	0.098	11.7	LOS B	1.1	8.4	0.34	0.56	0.34	35.7
All Vehicles		1104	6.3	1104	6.3	0.554	32.5	LOS C	8.0	62.4	0.77	0.70	0.77	30.3



DEVELOPMENT
ASSESSMENT PANEL
APPROVED
22-Mar-2024

MOVEMENT SUMMARY

Site: [Thundelarra Dr & Aurea Blvd - 2023 - AM (Site Folder: 2023)]

Network: N101 [AM (Network Folder: 2023)]

Site Category: (None)
Roundabout

Vehicle Movement Performance														
Mov ID	Turn	DEMAND FLOWS		ARRIVAL FLOWS		Deg. Satn v/c	Aver. Delay sec	Level of Service	95% BACK OF QUEUE		Prop. Que	Effective Stop Rate	Aver. No. Cycles	Aver. Speed km/h
		[Total veh/h]	[HV %]	[Total HV veh/h]	[HV %]				[Veh. veh]	[Dist m]				
South: Thundelarra Dr (S)														
1	L2	6	4.0	6	4.0	0.164	3.5	LOS A	1.0	7.7	0.39	0.57	0.39	41.7
2	T1	37	4.0	37	4.0	0.164	3.4	LOS A	1.0	7.7	0.39	0.57	0.39	25.5
3	R2	140	4.0	140	4.0	0.164	8.1	LOS A	1.0	7.7	0.39	0.57	0.39	25.5
3u	U	3	4.0	3	4.0	0.164	9.9	LOS A	1.0	7.7	0.39	0.57	0.39	28.6
Approach		186	4.0	186	4.0	0.164	7.0	LOS A	1.0	7.7	0.39	0.57	0.39	27.1
East: Aurea Blvd (E)														
4	L2	93	4.0	93	4.0	0.171	2.7	LOS A	1.1	8.4	0.30	0.43	0.30	33.5
5	T1	84	4.0	84	4.0	0.171	2.6	LOS A	1.1	8.4	0.30	0.43	0.30	47.0
6	R2	37	4.0	37	4.0	0.171	7.2	LOS A	1.1	8.4	0.30	0.43	0.30	29.1
6u	U	1	4.0	1	4.0	0.171	9.0	LOS A	1.1	8.4	0.30	0.43	0.30	29.1
Approach		215	4.0	215	4.0	0.171	3.5	LOS A	1.1	8.4	0.30	0.43	0.30	41.9
North: Thundelarra Dr (N)														
7	L2	43	4.0	43	4.0	0.098	2.9	LOS A	0.6	4.3	0.48	0.51	0.48	23.9
8	T1	40	4.0	40	4.0	0.098	3.1	LOS A	0.6	4.3	0.48	0.51	0.48	32.5
9	R2	16	4.0	16	4.0	0.098	7.1	LOS A	0.6	4.3	0.48	0.51	0.48	47.5
9u	U	1	4.0	1	4.0	0.098	8.9	LOS A	0.6	4.3	0.48	0.51	0.48	23.9
Approach		100	4.0	100	4.0	0.098	3.7	LOS A	0.6	4.3	0.48	0.51	0.48	36.7
West: Aurea Blvd (W)														
10	L2	14	4.0	14	4.0	0.123	4.1	LOS A	0.7	5.6	0.46	0.50	0.46	42.4
11	T1	89	4.0	89	4.0	0.123	4.0	LOS A	0.7	5.6	0.46	0.50	0.46	42.4
12	R2	18	4.0	18	4.0	0.123	8.8	LOS A	0.7	5.6	0.46	0.50	0.46	41.6
12u	U	8	4.0	8	4.0	0.123	10.6	LOS B	0.7	5.6	0.46	0.50	0.46	48.1
Approach		129	4.0	129	4.0	0.123	5.1	LOS A	0.7	5.6	0.46	0.50	0.46	42.9
All Vehicles		631	4.0	631	4.0	0.171	4.9	LOS A	1.1	8.4	0.38	0.50	0.38	38.7



MOVEMENT SUMMARY

Site: [Warnbro sound Ave & Aurea Blvd & Adelong Ave - 2023
- AM (Site Folder: 2023)]

Network: N101 [AM
(Network Folder: 2023)]

Site Category: (None)

Signals - EQUISAT (Fixed-Time/SCATS) Isolated Cycle Time = 90 seconds (Site Practical Cycle Time)

Vehicle Movement Performance														
Mov ID	Turn	DEMAND FLOWS		ARRIVAL FLOWS		Deg. Satn v/c	Aver. Delay sec	Level of Service	95% BACK OF QUEUE		Prop. Que	Effective Stop Rate	Aver. No. Cycles	Aver. Speed km/h
		[Total veh/h]	[HV %]	[Total veh/h]	[HV %]				[Veh. veh]	[Dist m]				
South: Warnbro Sound Ave (S)														
1	L2	58	4.0	58	4.0	0.042	6.8	LOS A	0.3	2.7	0.22	0.60	0.22	49.3
2	T1	239	5.8	239	5.8	0.279	30.9	LOS C	4.4	34.2	0.86	0.69	0.86	34.6
3	R2	7	4.0	7	4.0	0.042	46.3	LOS D	0.3	2.4	0.93	0.66	0.93	26.2
Approach		304	5.4	304	5.4	0.279	26.7	LOS C	4.4	34.2	0.74	0.67	0.74	36.0
East: Adelong Ave(E)														
4	L2	13	4.0	13	4.0	0.285	28.6	LOS C	2.7	20.9	0.91	0.71	0.91	34.3
5	T1	75	4.0	75	4.0	*0.285	24.0	LOS C	2.7	20.9	0.91	0.71	0.91	14.2
6	R2	21	4.0	21	4.0	0.078	40.3	LOS D	0.8	6.3	0.88	0.69	0.88	18.4
Approach		108	4.0	108	4.0	0.285	27.7	LOS C	2.7	20.9	0.91	0.71	0.91	19.0
North: Warnbro Sound Ave (N)														
7	L2	23	4.0	23	4.0	0.024	13.2	LOS B	0.4	3.2	0.47	0.63	0.47	34.3
8	T1	372	9.8	372	9.8	*0.451	32.5	LOS C	7.1	58.2	0.91	0.75	0.91	33.9
9	R2	81	4.0	81	4.0	*0.464	49.2	LOS D	3.6	27.8	0.99	0.77	0.99	12.0
Approach		476	8.5	476	8.5	0.464	34.4	LOS C	7.1	58.2	0.90	0.74	0.90	30.7
West: Aurea Blvd (W)														
10	L2	154	4.0	154	4.0	0.198	7.7	LOS A	2.3	18.1	0.43	0.57	0.43	38.4
11	T1	55	4.0	55	4.0	*0.198	3.8	LOS A	2.3	18.1	0.43	0.57	0.43	33.6
12	R2	63	4.0	63	4.0	0.148	33.0	LOS C	2.2	17.2	0.82	0.72	0.82	29.1
Approach		272	4.0	272	4.0	0.198	12.8	LOS B	2.3	18.1	0.52	0.61	0.52	33.4
All Vehicles		1160	6.2	1160	6.2	0.464	26.7	LOS C	7.1	58.2	0.77	0.69	0.77	31.8



DEVELOPMENT
ASSESSMENT PANEL

APPROVED
22-Mar-2024

MOVEMENT SUMMARY

Site: [Thundelarra Dr & Crossover 1 - 2023 - AM (Site Folder: 2023)]

Network: N101 [AM (Network Folder: 2023)]

Site Category: (None)
Give-Way (Two-Way)

Vehicle Movement Performance														
Mov ID	Turn	DEMAND FLOWS		ARRIVAL FLOWS		Deg. Satn	Aver. Delay	Level of Service	95% BACK OF QUEUE		Prop. Que	Effective Stop Rate	Aver. No. Cycles	Aver. Speed
		[Total veh/h]	[HV %]	[Total veh/h]	[HV %]				[Veh. veh]	[Dist m]				
South: Thundelarra Dr (S)														
2	T1	14	4.0	14	4.0	0.050	0.1	LOS A	0.2	1.8	0.12	0.40	0.12	43.9
3	R2	74	2.0	74	2.0	0.050	2.5	LOS A	0.2	1.8	0.12	0.40	0.12	30.2
Approach		87	2.3	87	2.3	0.050	2.2	NA	0.2	1.8	0.12	0.40	0.12	35.2
East: Crossover 1 (E)														
4	L2	91	2.0	91	2.0	0.068	0.0	LOS A	0.3	2.1	0.04	0.02	0.04	19.4
6	R2	13	2.0	13	2.0	0.068	0.9	LOS A	0.3	2.1	0.04	0.02	0.04	37.5
Approach		103	2.0	103	2.0	0.068	0.1	LOS A	0.3	2.1	0.04	0.02	0.04	25.3
North: Thundelarra Dr (N)														
7	L2	27	2.0	27	2.0	0.020	4.6	LOS A	0.0	0.0	0.00	0.40	0.00	36.6
8	T1	9	4.0	9	4.0	0.020	0.0	LOS A	0.0	0.0	0.00	0.40	0.00	40.9
Approach		37	2.5	37	2.5	0.020	3.4	NA	0.0	0.0	0.00	0.40	0.00	37.6
All Vehicles		227	2.2	227	2.2	0.068	1.4	NA	0.3	2.1	0.06	0.23	0.06	32.4

MOVEMENT SUMMARY

Site: [Aurea Blvd & Crossover 2 - 2023 - AM (Site Folder: 2023)]

Network: N101 [AM (Network Folder: 2023)]

Site Category: (None)
Give-Way (Two-Way)

Vehicle Movement Performance														
Mov ID	Turn	DEMAND FLOWS		ARRIVAL FLOWS		Deg. Satn	Aver. Delay	Level of Service	95% BACK OF QUEUE		Prop. Que	Effective Stop Rate	Aver. No. Cycles	Aver. Speed
		[Total veh/h]	[HV %]	[Total veh/h]	[HV %]				[Veh. veh]	[Dist m]				
East: Aurea Blvd (E)														
5	T1	214	4.0	214	4.0	0.116	0.0	LOS A	0.0	0.0	0.00	0.00	0.00	50.0
Approach		214	4.0	214	4.0	0.116	0.0	NA	0.0	0.0	0.00	0.00	0.00	50.0
North: Crossover 2 (N)														
7	L2	36	2.0	36	2.0	0.024	0.3	LOS A	0.1	0.7	0.19	0.07	0.19	17.9
Approach		36	2.0	36	2.0	0.024	0.3	LOS A	0.1	0.7	0.19	0.07	0.19	17.9
West: Aurea Blvd (W)														
10	L2	38	2.0	38	2.0	0.075	3.9	LOS A	0.0	0.0	0.00	0.15	0.00	24.5
11	T1	236	4.0	236	4.0	0.075	0.0	LOS A	0.0	0.0	0.00	0.06	0.00	45.3
Approach		274	3.7	274	3.7	0.075	0.5	NA	0.0	0.0	0.00	0.07	0.00	39.4
All Vehicles		523	3.7	523	3.7	0.116	0.3	NA	0.1	0.7	0.01	0.04	0.01	41.1



MOVEMENT SUMMARY

Site: [Thundelarra Dr & Aurea Blvd - 2023 - PM (Site Folder: Network: N101 [PM (Network Folder: 2023)]]

Site Category: (None)
Roundabout

Vehicle Movement Performance														
Mov ID	Turn	DEMAND FLOWS		ARRIVAL FLOWS		Deg. Satn	Aver. Delay	Level of Service	95% BACK OF QUEUE		Prop. Que	Effective Stop Rate	Aver. No. Cycles	Aver. Speed
		[Total veh/h	HV %	[Total veh/h	HV %				[Veh. veh	Dist] m				
South: Thundelarra Dr (S)														
1	L2	6	4.0	6	4.0	0.114	3.9	LOS A	0.7	5.2	0.45	0.57	0.45	42.2
2	T1	43	4.0	43	4.0	0.114	3.8	LOS A	0.7	5.2	0.45	0.57	0.45	26.0
3	R2	69	4.0	69	4.0	0.114	8.5	LOS A	0.7	5.2	0.45	0.57	0.45	26.0
3u	U	1	4.0	1	4.0	0.114	10.4	LOS B	0.7	5.2	0.45	0.57	0.45	29.1
Approach		120	4.0	120	4.0	0.114	6.6	LOS A	0.7	5.2	0.45	0.57	0.45	28.4
East: Aurea Blvd (E)														
4	L2	65	4.0	65	4.0	0.202	2.8	LOS A	1.3	10.3	0.33	0.44	0.33	33.0
5	T1	131	4.0	131	4.0	0.202	2.7	LOS A	1.3	10.3	0.33	0.44	0.33	46.6
6	R2	55	4.0	55	4.0	0.202	7.3	LOS A	1.3	10.3	0.33	0.44	0.33	28.7
6u	U	1	4.0	1	4.0	0.202	9.1	LOS A	1.3	10.3	0.33	0.44	0.33	28.7
Approach		252	4.0	252	4.0	0.202	3.8	LOS A	1.3	10.3	0.33	0.44	0.33	43.0
North: Thundelarra Dr (N)														
7	L2	54	4.0	54	4.0	0.126	2.4	LOS A	0.7	5.7	0.40	0.48	0.40	25.2
8	T1	56	4.0	56	4.0	0.126	2.6	LOS A	0.7	5.7	0.40	0.48	0.40	33.3
9	R2	29	4.0	29	4.0	0.126	6.5	LOS A	0.7	5.7	0.40	0.48	0.40	47.8
9u	U	1	4.0	1	4.0	0.126	8.4	LOS A	0.7	5.7	0.40	0.48	0.40	25.2
Approach		140	4.0	140	4.0	0.126	3.4	LOS A	0.7	5.7	0.40	0.48	0.40	39.1
West: Aurea Blvd (W)														
10	L2	22	4.0	22	4.0	0.110	3.8	LOS A	0.6	5.0	0.40	0.44	0.40	43.3
11	T1	89	4.0	89	4.0	0.110	3.7	LOS A	0.6	5.0	0.40	0.44	0.40	43.3
12	R2	7	4.0	7	4.0	0.110	8.4	LOS A	0.6	5.0	0.40	0.44	0.40	42.3
12u	U	2	4.0	2	4.0	0.110	10.3	LOS B	0.6	5.0	0.40	0.44	0.40	48.8
Approach		121	4.0	121	4.0	0.110	4.1	LOS A	0.6	5.0	0.40	0.44	0.40	43.4
All Vehicles		633	4.0	633	4.0	0.202	4.3	LOS A	1.3	10.3	0.38	0.47	0.38	40.7



MOVEMENT SUMMARY

Site: [Warnbro sound Ave & Aurea Blvd & Adelong Ave - 2023] Network: N101 [PM (Network - PM (Site Folder: 2023))]

Site Category: (None)

Signals - EQUISAT (Fixed-Time/SCATS) Isolated Cycle Time = 90 seconds (Site Practical Cycle Time)

Vehicle Movement Performance														
Mov ID	Turn	DEMAND FLOWS		ARRIVAL FLOWS		Deg. Satn	Aver. Delay	Level of Service	95% BACK OF QUEUE		Prop. Que	Effective Stop Rate	Aver. No. Cycles	Aver. Speed
		[Total veh/h]	[HV %]	[Total veh/h]	[HV %]				[Veh. veh]	[Dist m]				
South: Warnbro Sound Ave (S)														
1	L2	91	4.0	91	4.0	0.067	7.0	LOS A	0.6	4.7	0.23	0.61	0.23	49.1
2	T1	360	5.8	360	5.8	*0.519	36.4	LOS D	7.3	57.3	0.95	0.78	0.95	32.2
3	R2	5	4.0	5	4.0	0.021	41.6	LOS D	0.2	1.6	0.88	0.65	0.88	27.7
Approach		456	5.4	456	5.4	0.519	30.6	LOS C	7.3	57.3	0.81	0.74	0.81	34.0
East: Adelong Ave(E)														
4	L2	1	4.0	1	4.0	0.135	35.2	LOS D	1.3	10.5	0.89	0.67	0.89	31.4
5	T1	38	4.0	38	4.0	*0.135	30.6	LOS C	1.3	10.5	0.89	0.67	0.89	12.1
6	R2	22	4.0	22	4.0	0.081	40.3	LOS D	0.8	6.6	0.89	0.70	0.89	18.4
Approach		61	4.0	61	4.0	0.135	34.2	LOS C	1.3	10.5	0.89	0.68	0.89	15.5
North: Warnbro Sound Ave (N)														
7	L2	38	4.0	38	4.0	0.039	13.2	LOS B	0.7	5.2	0.47	0.64	0.47	34.3
8	T1	322	9.8	322	9.8	0.483	36.1	LOS D	6.5	53.0	0.94	0.76	0.94	32.3
9	R2	123	4.0	123	4.0	*0.488	45.4	LOS D	5.2	40.5	0.97	0.79	0.97	12.8
Approach		483	7.9	483	7.9	0.488	36.7	LOS D	6.5	53.0	0.91	0.76	0.91	28.3
West: Aurea Blvd (W)														
10	L2	139	4.0	139	4.0	0.127	5.6	LOS A	1.2	9.8	0.27	0.53	0.27	41.0
11	T1	22	4.0	22	4.0	*0.127	1.7	LOS A	1.2	9.8	0.27	0.53	0.27	36.4
12	R2	47	4.0	47	4.0	0.111	32.6	LOS C	1.6	12.7	0.81	0.71	0.81	29.2
Approach		208	4.0	208	4.0	0.127	11.3	LOS B	1.6	12.7	0.40	0.57	0.40	35.1
All Vehicles		1208	6.1	1208	6.1	0.519	29.9	LOS C	7.3	57.3	0.78	0.72	0.78	30.8



MOVEMENT SUMMARY

Site: [Thundelarra Dr & Crossover 1 - 2023 - PM (Site Folder: Network: N101 [PM (Network Folder: 2023)])]

Site Category: (None)
Give-Way (Two-Way)

Vehicle Movement Performance														
Mov ID	Turn	DEMAND FLOWS		ARRIVAL FLOWS		Deg. Satn	Aver. Delay	Level of Service	95% BACK OF QUEUE		Prop. Que	Effective Stop Rate	Aver. No. Cycles	Aver. Speed
		[Total veh/h	[HV %	[Total veh/h	[HV %	v/c	sec		[Veh. veh	[Dist m				km/h
South: Thundelarra Dr (S)														
2	T1	7	4.0	7	4.0	0.070	0.1	LOS A	0.3	2.5	0.13	0.44	0.13	43.3
3	R2	113	2.0	113	2.0	0.070	2.6	LOS A	0.3	2.5	0.13	0.44	0.13	28.9
Approach		120	2.1	120	2.1	0.070	2.4	NA	0.3	2.5	0.13	0.44	0.13	31.2
East: Crossover 1 (E)														
4	L2	136	2.0	136	2.0	0.105	0.0	LOS A	0.4	3.3	0.01	0.02	0.01	19.5
6	R2	23	2.0	23	2.0	0.105	1.0	LOS A	0.4	3.3	0.01	0.02	0.01	37.6
Approach		159	2.0	159	2.0	0.105	0.2	LOS A	0.4	3.3	0.01	0.02	0.01	26.3
North: Thundelarra Dr (N)														
7	L2	43	2.0	43	2.0	0.025	4.6	LOS A	0.0	0.0	0.00	0.51	0.00	35.2
8	T1	2	4.0	2	4.0	0.025	0.0	LOS A	0.0	0.0	0.00	0.51	0.00	39.0
Approach		45	2.1	45	2.1	0.025	4.4	NA	0.0	0.0	0.00	0.51	0.00	35.4
All Vehicles		324	2.1	324	2.1	0.105	1.6	NA	0.4	3.3	0.05	0.24	0.05	30.5

MOVEMENT SUMMARY

Site: [Aurea Blvd & Crossover 2 - 2023 - PM (Site Folder: Network: N101 [PM (Network Folder: 2023)])]

Site Category: (None)
Give-Way (Two-Way)

Vehicle Movement Performance														
Mov ID	Turn	DEMAND FLOWS		ARRIVAL FLOWS		Deg. Satn	Aver. Delay	Level of Service	95% BACK OF QUEUE		Prop. Que	Effective Stop Rate	Aver. No. Cycles	Aver. Speed
		[Total veh/h	[HV %	[Total veh/h	[HV %	v/c	sec		[Veh. veh	[Dist m				km/h
East: Aurea Blvd (E)														
5	T1	252	4.0	252	4.0	0.137	0.0	LOS A	0.0	0.0	0.00	0.00	0.00	49.9
Approach		252	4.0	252	4.0	0.137	0.0	NA	0.0	0.0	0.00	0.00	0.00	49.9
North: Crossover 2 (N)														
7	L2	57	2.0	57	2.0	0.037	0.1	LOS A	0.1	1.1	0.12	0.03	0.12	18.6
Approach		57	2.0	57	2.0	0.037	0.1	LOS A	0.1	1.1	0.12	0.03	0.12	18.6
West: Aurea Blvd (W)														
10	L2	60	2.0	60	2.0	0.058	3.9	LOS A	0.0	0.0	0.00	0.30	0.00	22.6
11	T1	152	4.0	152	4.0	0.058	0.0	LOS A	0.0	0.0	0.00	0.09	0.00	43.5
Approach		212	3.4	212	3.4	0.058	1.1	NA	0.0	0.0	0.00	0.15	0.00	32.9
All Vehicles		520	3.6	520	3.6	0.137	0.5	NA	0.1	1.1	0.01	0.07	0.01	37.4



DEVELOPMENT
ASSESSMENT PANEL

APPROVED
22-Mar-2024

MOVEMENT SUMMARY

Site: [Thundelarra Dr & Aurea Blvd - 2033 - AM (Site Folder: 2033)]

Network: N101 [AM (Network Folder: 2033)]

Site Category: (None)
Roundabout

Vehicle Movement Performance														
Mov ID	Turn	DEMAND FLOWS		ARRIVAL FLOWS		Deg. Satn	Aver. Delay	Level of Service	95% BACK OF QUEUE		Prop. Que	Effective Stop Rate	Aver. No. Cycles	Aver. Speed
		[Total veh/h]	[HV %]	[Total HV veh/h]	[%]				[Veh. veh]	[Dist m]				
South: Thundelarra Dr (S)														
1	L2	7	4.0	7	4.0	0.200	3.6	LOS A	1.2	9.7	0.43	0.59	0.43	41.4
2	T1	40	4.0	40	4.0	0.200	3.5	LOS A	1.2	9.7	0.43	0.59	0.43	25.2
3	R2	172	4.0	172	4.0	0.200	8.3	LOS A	1.2	9.7	0.43	0.59	0.43	25.2
3u	U	4	4.0	4	4.0	0.200	10.1	LOS B	1.2	9.7	0.43	0.59	0.43	28.3
Approach		223	4.0	223	4.0	0.200	7.3	LOS A	1.2	9.7	0.43	0.59	0.43	26.7
East: Aurea Blvd (E)														
4	L2	113	4.0	113	4.0	0.203	2.8	LOS A	1.3	10.3	0.33	0.43	0.33	33.4
5	T1	102	4.0	102	4.0	0.203	2.8	LOS A	1.3	10.3	0.33	0.43	0.33	47.0
6	R2	37	4.0	37	4.0	0.203	7.3	LOS A	1.3	10.3	0.33	0.43	0.33	28.9
6u	U	1	4.0	1	4.0	0.203	9.1	LOS A	1.3	10.3	0.33	0.43	0.33	28.9
Approach		253	4.0	253	4.0	0.203	3.4	LOS A	1.3	10.3	0.33	0.43	0.33	42.0
North: Thundelarra Dr (N)														
7	L2	43	4.0	43	4.0	0.109	3.3	LOS A	0.6	4.9	0.53	0.55	0.53	22.8
8	T1	44	4.0	44	4.0	0.109	3.5	LOS A	0.6	4.9	0.53	0.55	0.53	31.6
9	R2	17	4.0	17	4.0	0.109	7.5	LOS A	0.6	4.9	0.53	0.55	0.53	47.0
9u	U	1	4.0	1	4.0	0.109	9.3	LOS A	0.6	4.9	0.53	0.55	0.53	22.8
Approach		105	4.0	105	4.0	0.109	4.1	LOS A	0.6	4.9	0.53	0.55	0.53	35.9
West: Aurea Blvd (W)														
10	L2	14	4.0	14	4.0	0.154	4.4	LOS A	0.9	7.2	0.50	0.53	0.50	42.1
11	T1	109	4.0	109	4.0	0.154	4.3	LOS A	0.9	7.2	0.50	0.53	0.50	42.1
12	R2	22	4.0	22	4.0	0.154	9.1	LOS A	0.9	7.2	0.50	0.53	0.50	41.3
12u	U	11	4.0	11	4.0	0.154	10.9	LOS B	0.9	7.2	0.50	0.53	0.50	47.9
Approach		156	4.0	156	4.0	0.154	5.4	LOS A	0.9	7.2	0.50	0.53	0.50	42.6
All Vehicles		737	4.0	737	4.0	0.203	5.1	LOS A	1.3	10.3	0.42	0.52	0.42	38.5



MOVEMENT SUMMARY

Site: [Warnbro sound Ave & Aurea Blvd & Adelong Ave - 2033
- AM (Site Folder: 2033)]

Network: N101 [AM
(Network Folder: 2033)]

Site Category: (None)

Signals - EQUISAT (Fixed-Time/SCATS) Isolated Cycle Time = 90 seconds (Site Practical Cycle Time)

Vehicle Movement Performance														
Mov ID	Turn	DEMAND FLOWS		ARRIVAL FLOWS		Deg. Satn	Aver. Delay	Level of Service	95% BACK OF QUEUE		Prop. Que	Effective Stop Rate	Aver. No. Cycles	Aver. Speed
		[Total veh/h]	[HV %]	[Total veh/h]	[HV %]				[Veh. veh]	[Dist m]				
South: Warnbro Sound Ave (S)														
1	L2	68	4.0	68	4.0	0.050	6.9	LOS A	0.4	3.5	0.23	0.60	0.23	49.1
2	T1	293	5.8	293	5.8	0.342	31.5	LOS C	5.4	42.7	0.88	0.71	0.88	34.4
3	R2	9	4.0	9	4.0	0.054	46.4	LOS D	0.4	3.0	0.93	0.67	0.93	26.2
Approach		371	5.4	371	5.4	0.342	27.3	LOS C	5.4	42.7	0.76	0.69	0.76	35.6
East: Adelong Ave(E)														
4	L2	16	4.0	16	4.0	0.339	28.2	LOS C	3.1	24.3	0.92	0.73	0.92	34.5
5	T1	88	4.0	88	4.0	*0.339	23.6	LOS C	3.1	24.3	0.92	0.73	0.92	14.4
6	R2	26	4.0	26	4.0	0.097	40.5	LOS D	1.0	7.9	0.89	0.70	0.89	18.4
Approach		131	4.0	131	4.0	0.339	27.6	LOS C	3.1	24.3	0.92	0.73	0.92	19.2
North: Warnbro Sound Ave (N)														
7	L2	28	4.0	28	4.0	0.029	13.2	LOS B	0.5	3.9	0.47	0.63	0.47	34.3
8	T1	455	9.8	455	9.8	*0.552	33.4	LOS C	9.0	73.2	0.93	0.78	0.93	33.5
9	R2	97	4.0	97	4.0	*0.555	49.8	LOS D	4.3	33.7	1.00	0.78	1.01	11.9
Approach		580	8.5	580	8.5	0.555	35.2	LOS D	9.0	73.2	0.92	0.77	0.92	30.4
West: Aurea Blvd (W)														
10	L2	184	4.0	184	4.0	0.238	7.7	LOS A	2.6	20.0	0.45	0.58	0.45	38.4
11	T1	65	4.0	65	4.0	*0.238	3.7	LOS A	2.6	20.0	0.45	0.58	0.45	33.6
12	R2	74	4.0	74	4.0	0.173	33.2	LOS C	2.6	20.2	0.83	0.73	0.83	29.0
Approach		323	4.0	323	4.0	0.238	12.7	LOS B	2.6	20.2	0.53	0.62	0.53	33.4
All Vehicles		1404	6.3	1404	6.3	0.555	27.2	LOS C	9.0	73.2	0.79	0.71	0.79	31.6



DEVELOPMENT
ASSESSMENT PANEL

APPROVED
22-Mar-2024

MOVEMENT SUMMARY

Site: [Thundelarra Dr & Crossover 1 - 2033 - AM (Site Folder: 2033)]

Network: N101 [AM (Network Folder: 2033)]

Site Category: (None)
Give-Way (Two-Way)

Vehicle Movement Performance														
Mov ID	Turn	DEMAND FLOWS		ARRIVAL FLOWS		Deg. Satn	Aver. Delay	Level of Service	95% BACK OF QUEUE		Prop. Que	Effective Stop Rate	Aver. No. Cycles	Aver. Speed
		[Total veh/h]	[HV %]	[Total veh/h]	[HV %]				[Veh. veh]	[Dist m]				
South: Thundelarra Dr (S)														
2	T1	17	4.0	17	4.0	0.052	0.1	LOS A	0.2	1.9	0.12	0.39	0.12	44.0
3	R2	74	2.0	74	2.0	0.052	2.6	LOS A	0.2	1.9	0.12	0.39	0.12	30.4
Approach		91	2.4	91	2.4	0.052	2.1	NA	0.2	1.9	0.12	0.39	0.12	36.1
East: Crossover 1 (E)														
4	L2	91	2.0	91	2.0	0.068	0.0	LOS A	0.3	2.1	0.05	0.03	0.05	19.2
6	R2	13	2.0	13	2.0	0.068	0.9	LOS A	0.3	2.1	0.05	0.03	0.05	37.4
Approach		103	2.0	103	2.0	0.068	0.1	LOS A	0.3	2.1	0.05	0.03	0.05	25.1
North: Thundelarra Dr (N)														
7	L2	27	2.0	27	2.0	0.023	4.6	LOS A	0.0	0.0	0.00	0.35	0.00	37.3
8	T1	15	4.0	15	4.0	0.023	0.0	LOS A	0.0	0.0	0.00	0.35	0.00	41.8
Approach		42	2.7	42	2.7	0.023	3.0	NA	0.0	0.0	0.00	0.35	0.00	38.7
All Vehicles		236	2.3	236	2.3	0.068	1.4	NA	0.3	2.1	0.07	0.22	0.07	33.2

MOVEMENT SUMMARY

Site: [Aurea Blvd & Crossover 2 - 2033 - AM (Site Folder: 2033)]

Network: N101 [AM (Network Folder: 2033)]

Site Category: (None)
Give-Way (Two-Way)

Vehicle Movement Performance														
Mov ID	Turn	DEMAND FLOWS		ARRIVAL FLOWS		Deg. Satn	Aver. Delay	Level of Service	95% BACK OF QUEUE		Prop. Que	Effective Stop Rate	Aver. No. Cycles	Aver. Speed
		[Total veh/h]	[HV %]	[Total veh/h]	[HV %]				[Veh. veh]	[Dist m]				
East: Aurea Blvd (E)														
5	T1	254	4.0	254	4.0	0.138	0.0	LOS A	0.0	0.0	0.00	0.00	0.00	49.9
Approach		254	4.0	254	4.0	0.138	0.0	NA	0.0	0.0	0.00	0.00	0.00	49.9
North: Crossover 2 (N)														
7	L2	36	2.0	36	2.0	0.025	0.4	LOS A	0.1	0.7	0.22	0.09	0.22	17.6
Approach		36	2.0	36	2.0	0.025	0.4	LOS A	0.1	0.7	0.22	0.09	0.22	17.6
West: Aurea Blvd (W)														
10	L2	38	2.0	38	2.0	0.089	3.9	LOS A	0.0	0.0	0.00	0.13	0.00	24.8
11	T1	287	4.0	287	4.0	0.089	0.0	LOS A	0.0	0.0	0.00	0.05	0.00	45.8
Approach		325	3.8	325	3.8	0.089	0.5	NA	0.0	0.0	0.00	0.06	0.00	40.7
All Vehicles		615	3.8	615	3.8	0.138	0.3	NA	0.1	0.7	0.01	0.04	0.01	42.2



DEVELOPMENT
ASSESSMENT PANEL

APPROVED
22-Mar-2024

MOVEMENT SUMMARY

Site: [Thundelarra Dr & Aurea Blvd - 2033 - PM (Site Folder: Network: N101 [PM (Network Folder: 2033)]]

Site Category: (None)
Roundabout

Vehicle Movement Performance														
Mov ID	Turn	DEMAND FLOWS		ARRIVAL FLOWS		Deg. Satn	Aver. Delay	Level of Service	95% BACK OF QUEUE		Prop. Que	Effective Stop Rate	Aver. No. Cycles	Aver. Speed
		[Total veh/h	HV %	[Total veh/h	HV %				[Veh. veh	Dist] m				
South: Thundelarra Dr (S)														
1	L2	7	4.0	7	4.0	0.133	4.1	LOS A	0.8	6.1	0.49	0.59	0.49	41.9
2	T1	44	4.0	44	4.0	0.133	4.0	LOS A	0.8	6.1	0.49	0.59	0.49	25.5
3	R2	83	4.0	83	4.0	0.133	8.8	LOS A	0.8	6.1	0.49	0.59	0.49	25.5
3u	U	1	4.0	1	4.0	0.133	10.6	LOS B	0.8	6.1	0.49	0.59	0.49	28.7
Approach		136	4.0	136	4.0	0.133	7.0	LOS A	0.8	6.1	0.49	0.59	0.49	28.0
East: Aurea Blvd(E)														
4	L2	80	4.0	80	4.0	0.239	2.8	LOS A	1.6	12.6	0.35	0.44	0.35	33.0
5	T1	160	4.0	160	4.0	0.239	2.8	LOS A	1.6	12.6	0.35	0.44	0.35	46.6
6	R2	56	4.0	56	4.0	0.239	7.3	LOS A	1.6	12.6	0.35	0.44	0.35	28.6
6u	U	1	4.0	1	4.0	0.239	9.2	LOS A	1.6	12.6	0.35	0.44	0.35	28.6
Approach		297	4.0	297	4.0	0.239	3.7	LOS A	1.6	12.6	0.35	0.44	0.35	43.2
North: Thundelarra Dr (N)														
7	L2	54	4.0	54	4.0	0.135	2.6	LOS A	0.8	6.2	0.44	0.50	0.44	24.5
8	T1	59	4.0	59	4.0	0.135	2.8	LOS A	0.8	6.2	0.44	0.50	0.44	32.8
9	R2	31	4.0	31	4.0	0.135	6.8	LOS A	0.8	6.2	0.44	0.50	0.44	47.5
9u	U	1	4.0	1	4.0	0.135	8.6	LOS A	0.8	6.2	0.44	0.50	0.44	24.5
Approach		144	4.0	144	4.0	0.135	3.6	LOS A	0.8	6.2	0.44	0.50	0.44	38.6
West: Aurea Blvd (W)														
10	L2	22	4.0	22	4.0	0.131	3.9	LOS A	0.8	6.1	0.43	0.45	0.43	43.1
11	T1	108	4.0	108	4.0	0.131	3.8	LOS A	0.8	6.1	0.43	0.45	0.43	43.1
12	R2	9	4.0	9	4.0	0.131	8.6	LOS A	0.8	6.1	0.43	0.45	0.43	42.2
12u	U	2	4.0	2	4.0	0.131	10.4	LOS B	0.8	6.1	0.43	0.45	0.43	48.6
Approach		142	4.0	142	4.0	0.131	4.2	LOS A	0.8	6.1	0.43	0.45	0.43	43.2
All Vehicles		719	4.0	719	4.0	0.239	4.4	LOS A	1.6	12.6	0.41	0.48	0.41	40.7



MOVEMENT SUMMARY

Site: [Warnbro sound Ave & Aurea Blvd & Adelong Ave - 2033] Network: N101 [PM (Network - PM (Site Folder: 2033)) Folder: 2033]]

Site Category: (None)

Signals - EQUISAT (Fixed-Time/SCATS) Isolated Cycle Time = 90 seconds (Site Practical Cycle Time)

Vehicle Movement Performance														
Mov ID	Turn	DEMAND FLOWS		ARRIVAL FLOWS		Deg. Satn	Aver. Delay	Level of Service	95% BACK OF QUEUE		Prop. Que	Effective Stop Rate	Aver. No. Cycles	Aver. Speed
		[Total veh/h]	[HV %]	[Total veh/h]	[HV %]				[Veh. veh]	[Dist. m]				
South: Warnbro Sound Ave (S)														
1	L2	106	4.0	106	4.0	0.080	7.1	LOS A	0.8	6.0	0.25	0.61	0.25	48.8
2	T1	441	5.8	441	5.8	*0.636	37.5	LOS D	9.2	72.5	0.97	0.82	0.99	31.7
3	R2	6	4.0	6	4.0	0.025	41.7	LOS D	0.2	1.9	0.88	0.66	0.88	27.7
Approach		554	5.4	554	5.4	0.636	31.8	LOS C	9.2	72.5	0.83	0.77	0.85	33.5
East: Adelong Ave(E)														
4	L2	3	4.0	3	4.0	0.150	28.4	LOS C	1.3	10.3	0.89	0.67	0.89	34.6
5	T1	41	4.0	41	4.0	*0.150	23.8	LOS C	1.3	10.3	0.89	0.67	0.89	14.4
6	R2	27	4.0	27	4.0	0.101	40.5	LOS D	1.1	8.2	0.89	0.70	0.89	18.4
Approach		72	4.0	72	4.0	0.150	30.4	LOS C	1.3	10.3	0.89	0.68	0.89	17.7
North: Warnbro Sound Ave (N)														
7	L2	46	4.0	46	4.0	0.048	13.2	LOS B	0.8	6.4	0.48	0.65	0.48	34.2
8	T1	393	9.8	393	9.8	0.588	37.0	LOS D	8.1	66.1	0.96	0.79	0.96	32.0
9	R2	148	4.0	148	4.0	*0.589	46.2	LOS D	6.4	49.8	0.98	0.80	0.99	12.7
Approach		587	7.9	587	7.9	0.589	37.4	LOS D	8.1	66.1	0.93	0.78	0.93	28.0
West: Aurea Blvd (W)														
10	L2	165	4.0	165	4.0	0.153	6.2	LOS A	1.8	14.3	0.31	0.55	0.31	39.9
11	T1	25	4.0	25	4.0	*0.153	2.2	LOS A	1.8	14.3	0.31	0.55	0.31	35.2
12	R2	53	4.0	53	4.0	0.123	32.7	LOS C	1.8	14.2	0.81	0.72	0.81	29.1
Approach		243	4.0	243	4.0	0.153	11.5	LOS B	1.8	14.3	0.42	0.59	0.42	34.7
All Vehicles		1456	6.1	1456	6.1	0.636	30.6	LOS C	9.2	72.5	0.81	0.74	0.81	30.6



DEVELOPMENT
ASSESSMENT PANEL

APPROVED
22-Mar-2024

MOVEMENT SUMMARY

Site: [Thundelarra Dr & Crossover 1 - 2033 - PM (Site Folder: Network: N101 [PM (Network 2033)] Folder: 2033)]

Site Category: (None)
Give-Way (Two-Way)

Vehicle Movement Performance														
Mov ID	Turn	DEMAND FLOWS		ARRIVAL FLOWS		Deg. Satn	Aver. Delay	Level of Service	95% BACK OF QUEUE		Prop. Que	Effective Stop Rate	Aver. No. Cycles	Aver. Speed
		[Total vch/h]	[HV %]	[Total vch/h]	[HV %]				[Veh. vch]	[Dist m]				
South: Thundelarra Dr (S)														
2	T1	9	4.0	9	4.0	0.072	0.2	LOS A	0.3	2.6	0.14	0.44	0.14	43.3
3	R2	113	2.0	113	2.0	0.072	2.6	LOS A	0.3	2.6	0.14	0.44	0.14	28.9
Approach		122	2.2	122	2.2	0.072	2.4	NA	0.3	2.6	0.14	0.44	0.14	31.8
East: Crossover 1 (E)														
4	L2	136	2.0	136	2.0	0.106	0.0	LOS A	0.4	3.3	0.03	0.02	0.03	19.4
6	R2	23	2.0	23	2.0	0.106	1.1	LOS A	0.4	3.3	0.03	0.02	0.03	37.6
Approach		159	2.0	159	2.0	0.106	0.2	LOS A	0.4	3.3	0.03	0.02	0.03	26.2
North: Thundelarra Dr (N)														
7	L2	43	2.0	43	2.0	0.028	4.6	LOS A	0.0	0.0	0.00	0.46	0.00	35.9
8	T1	7	4.0	7	4.0	0.028	0.0	LOS A	0.0	0.0	0.00	0.46	0.00	39.9
Approach		51	2.3	51	2.3	0.028	4.0	NA	0.0	0.0	0.00	0.46	0.00	36.4
All Vehicles		332	2.1	332	2.1	0.106	1.6	NA	0.4	3.3	0.07	0.24	0.07	31.1

MOVEMENT SUMMARY

Site: [Aurea Blvd & Crossover 2 - 2033 - PM (Site Folder: Network: N101 [PM (Network 2033)] Folder: 2033)]

Site Category: (None)
Give-Way (Two-Way)

Vehicle Movement Performance														
Mov ID	Turn	DEMAND FLOWS		ARRIVAL FLOWS		Deg. Satn	Aver. Delay	Level of Service	95% BACK OF QUEUE		Prop. Que	Effective Stop Rate	Aver. No. Cycles	Aver. Speed
		[Total vch/h]	[HV %]	[Total vch/h]	[HV %]				[Veh. vch]	[Dist m]				
East: Aurea Blvd (E)														
5	T1	295	4.0	295	4.0	0.160	0.0	LOS A	0.0	0.0	0.00	0.00	0.00	49.9
Approach		295	4.0	295	4.0	0.160	0.0	NA	0.0	0.0	0.00	0.00	0.00	49.9
North: Crossover 2 (N)														
7	L2	57	2.0	57	2.0	0.037	0.2	LOS A	0.1	1.1	0.15	0.04	0.15	18.3
Approach		57	2.0	57	2.0	0.037	0.2	LOS A	0.1	1.1	0.15	0.04	0.15	18.3
West: Aurea Blvd (W)														
10	L2	60	2.0	60	2.0	0.067	3.9	LOS A	0.0	0.0	0.00	0.26	0.00	23.0
11	T1	185	4.0	185	4.0	0.067	0.0	LOS A	0.0	0.0	0.00	0.09	0.00	43.7
Approach		245	3.5	245	3.5	0.067	1.0	NA	0.0	0.0	0.00	0.13	0.00	34.3
All Vehicles		597	3.6	597	3.6	0.160	0.4	NA	0.1	1.1	0.01	0.06	0.01	38.6



DEVELOPMENT
ASSESSMENT PANEL

APPROVED
22-Mar-2024

Appendix C

TURN PATH ANALYSIS

DEVELOPMENT
ASSESSMENT PANEL

APPROVED
22-Mar-2024



2 Aurea Blvd, Golden Bay
 19.0 m Semi-railers
 Fuel tanker circulation

LEGEND
 Vehicle Body
 Wheel Path
 500mm Clearance



t22.035.s01b
 1/5/2023
 Scale: 1:400 @ A3



**DEVELOPMENT
 ASSESSMENT PANEL**

APPROVED

12-Mar-2024



2 Aurea Blvd, Golden Bay
 8.8 MRV
 Service vehicle entry

LEGEND
 Vehicle Body
 Wheel Path
 500mm Clearance



t22.035.sk03b
 1/5/2023
 Scale: 1:500 @ A3



**DEVELOPMENT
 ASSESSMENT PANEL**
APPROVED
 12-Mar-2024



2 Aurea Blvd, Golden Bay
 8.8 MRV
 Service vehicle exit

LEGEND

- Vehicle Body
- Wheel Path
- 500mm Clearance

t22.035.sk04b
 1/5/2023
 Scale: 1:500 @ A3



**DEVELOPMENT
ASSESSMENT PANEL**

APPROVED

12-Mar-2024

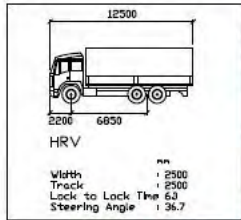

2 Aurea Blvd, Golden Bay
 12.5 Rigid Truck
 Service vehicle entry

LEGEND
 Vehicle Body
 Wheel Path
 500mm Clearance



t22.035.sk06b
 1/5/2023
 Scale: 1:300 @ A3



**DEVELOPMENT
 ASSESSMENT PANEL**

APPROVED

12-Mar-2024



2 Aurea Blvd, Golden Bay
 12.5 Rigid Truck
 Service vehicle exit

LEGEND
 Vehicle Body █
 Wheel Path █
 500mm Clearance █

t22.035.sk06b
 1/5/2023
 Scale: 1:300 @ A3



**DEVELOPMENT
 ASSESSMENT PANEL**

APPROVED

12-Mar-2024

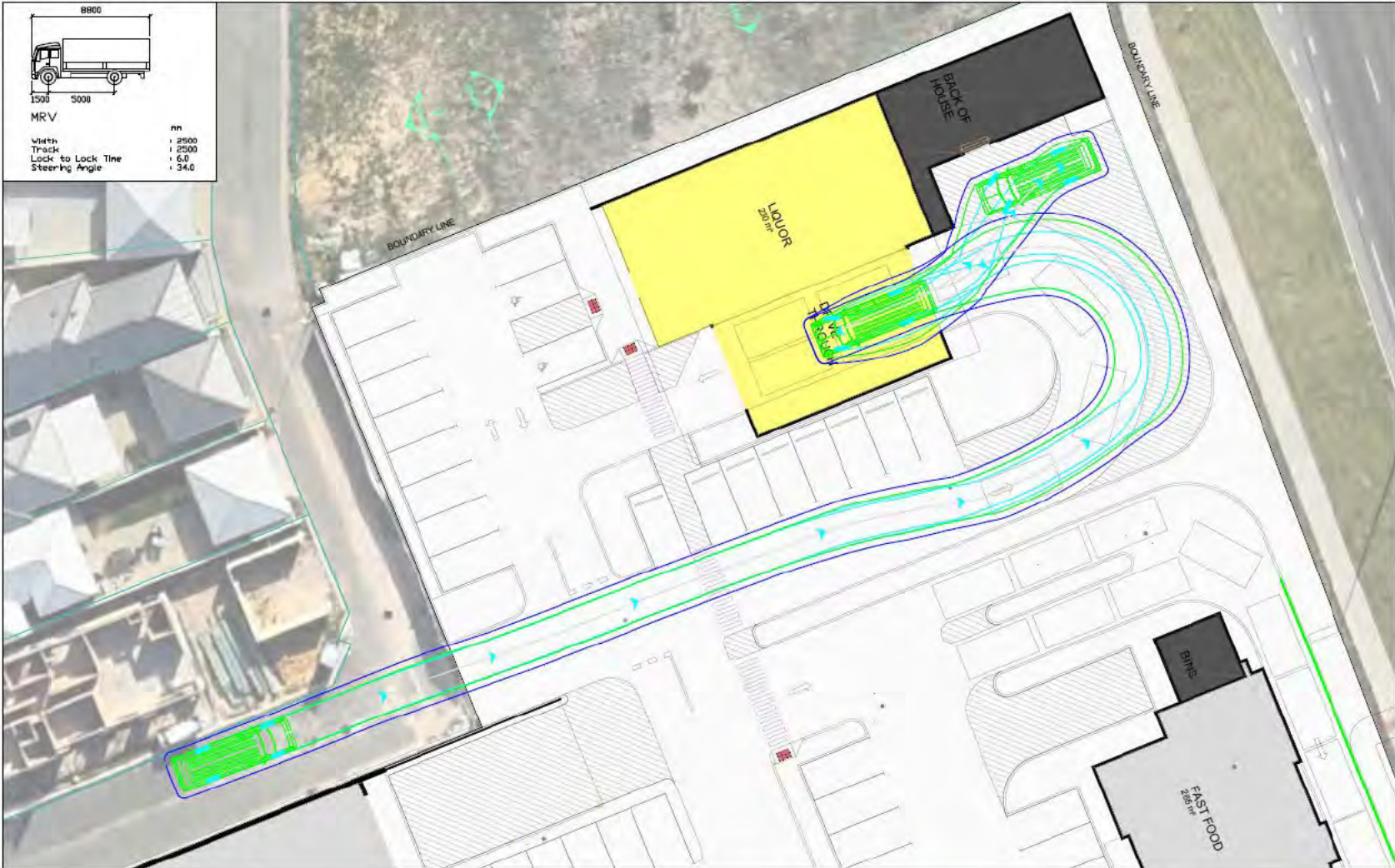

2 Aurea Blvd, Golden Bay
 8.8 m MRV
 Service vehicle entry

LEGEND

- Vehicle Body
- Wheel Path
- 500mm Clearance

t22.035.sk11b

1/5/2023

Scale: 1:250 @ A3



**DEVELOPMENT
ASSESSMENT PANEL**

APPROVED

12-Mar-2024

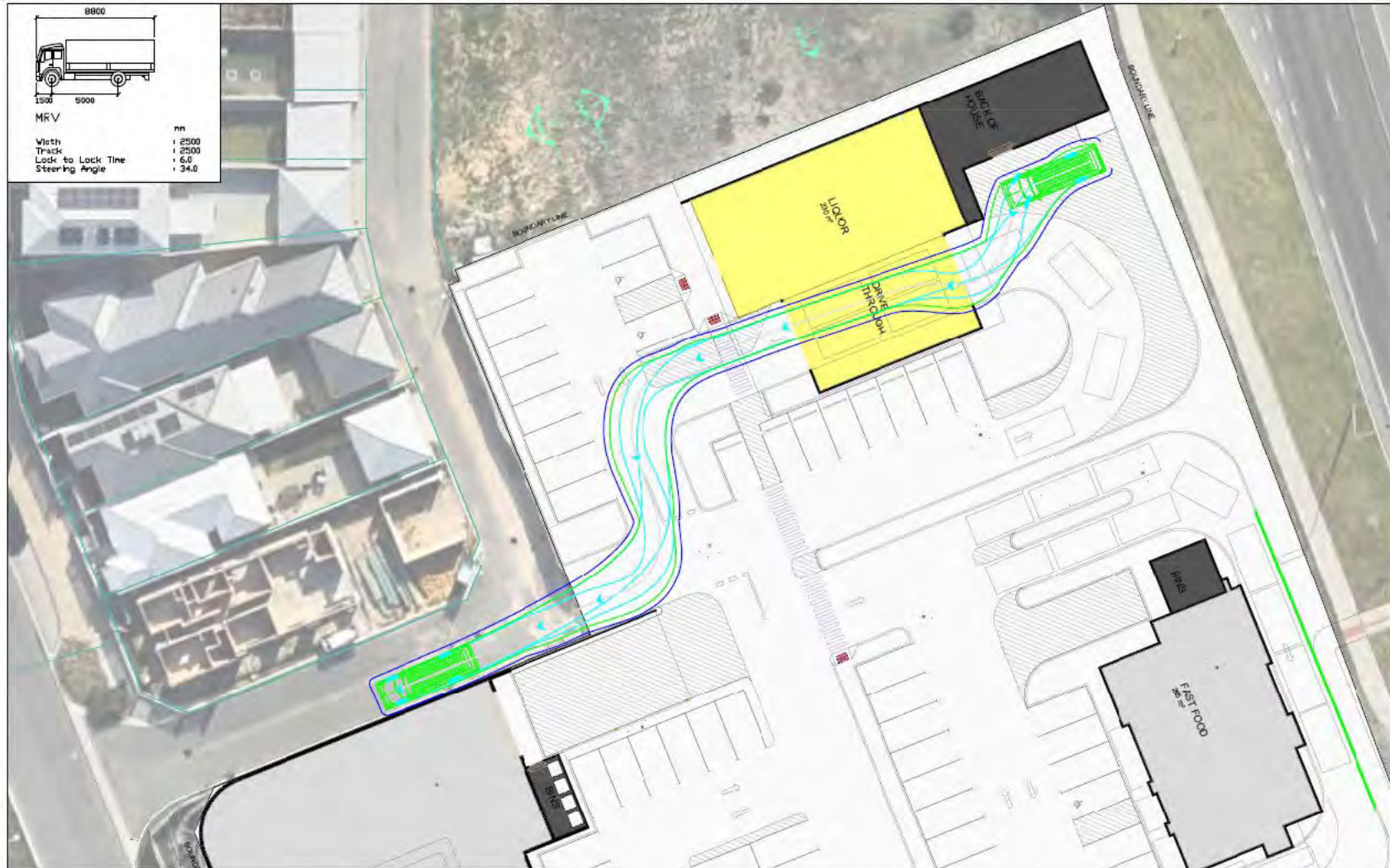

2 Aurea Blvd, Golden Bay
 8.8 m MRV
 Service vehicle exit

LEGEND
 Vehicle Body █
 Wheel Path █
 500mm Clearance █

t22.035.sk12b
 1/5/2023
 Scale: 1:300 @ A3





2 Aurea Blvd, Golden Bay
 8.8m Service Vehicle
 Service vehicle entry

LEGEND
 Vehicle Body
 Wheel Path
 500mm Clearance

t22.035.sk16a
 1/5/2023
 Scale: 1:200 @ A3



**DEVELOPMENT
 ASSESSMENT PANEL**

APPROVED
 12-Mar-2024

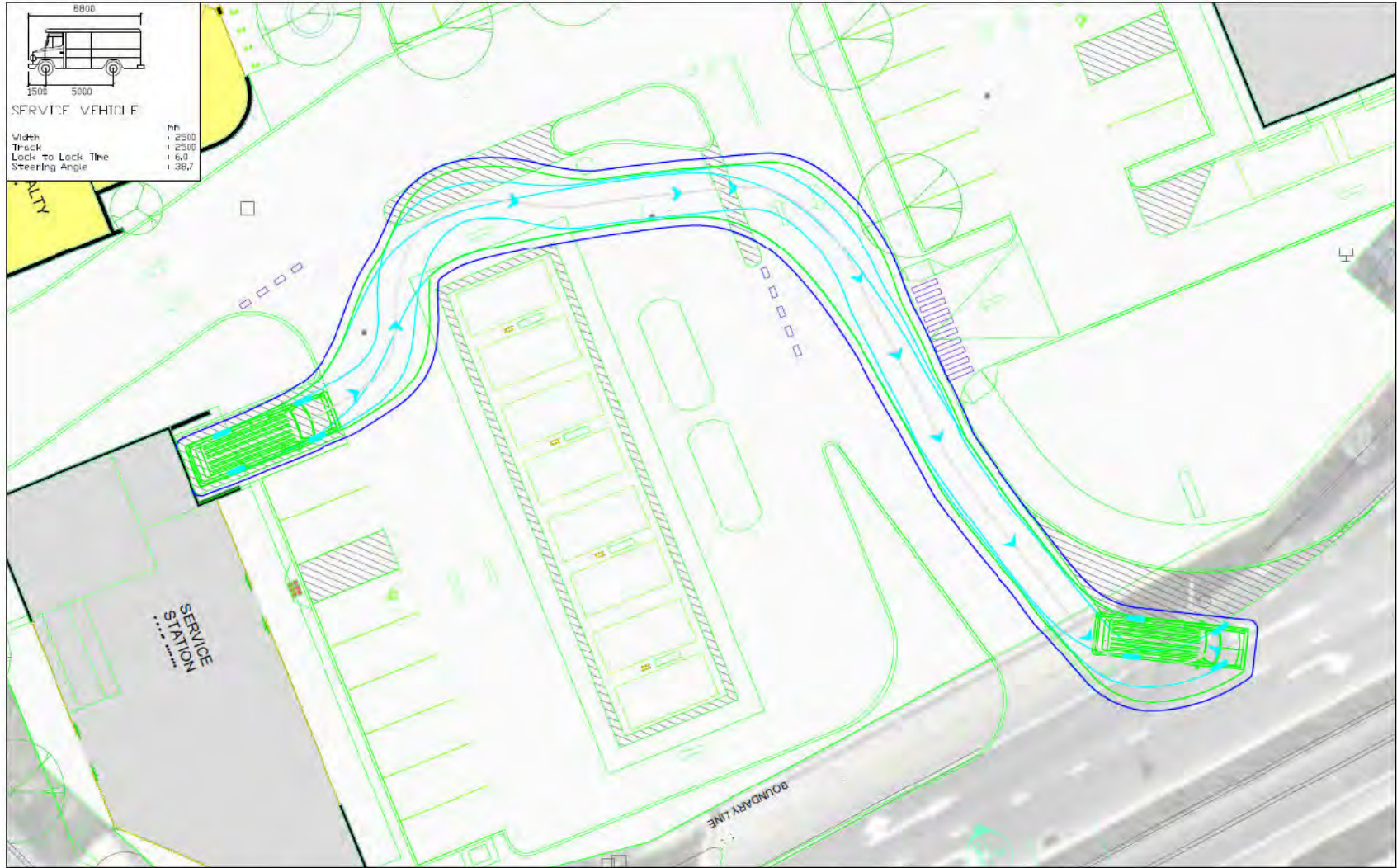

2 Aurea Blvd, Golden Bay
 8.8m Service Vehicle
 Service vehicle exit

t22.035.sk17a
 1/5/2023
 Scale: 1:200 @ A3



DEVELOPMENT ASSESSMENT PANEL

APPROVED

12-Mar-2024

Technical Note: No. 1**Date:** 30/11/2023**Project No:** t23.035**Project:** Lot 622 (No. 2) Aurea Boulevard, Golden Bay**Subject:** Proposed Neighbourhood Centre - Revised Plan

1. Introduction

The proposed development at the above-mentioned site was refused by JDAP on July 10, 2023. Subsequently, the application was referred to the State Administrative Tribunal (SAT). Currently, the matter is in mediation, and the first mediation session took place on Monday, October 23, 2023.

Following the first mediation, several actions were agreed upon, which subsequently lead to a revised development plan. Accordingly, Transcore has been requested to prepare an Addendum Report (to the Revised Transport Impact Assessment dated May 2023) with respect to these actions and the revised development plan. The identified actions are as follows:

1. Provide pedestrian refuge within Thundelarra Drive crossover, to be constructed of rollover kerb to prevent interference with service vehicles;
2. Convert existing on-street bays along Aurea Boulevard to a left turn pocket;
3. Show pedestrian path and pram ramps along Aurea Boulevard crossover.
4. Provide blind aisle turning bay for Liquor Store parking area;
5. Move fuel bowsers closer to the convenience store building to the extent possible; and,
6. Change configuration of refuelling area to one way.

This technical note serves as an addendum to the original Revised TIA prepared by Transcore in May 2023.

2. Revised Development Plan

Appendix A illustrates the revised development plan. The revised plan indicates the following modifications to the proposed Aurea Blvd and Thundelarra Drive crossovers:

- Amendment of Thundelarra Drive crossover and provision of a pedestrian refuge;
- Provision of a mountable apron on the southern side of the Thundelarra Drive crossover;
- Removal of the mountable apron from the east side of the Aurea Blvd crossover;

- Removal of the on-street parking bays and provision of a left turn pocket on Aurea Blvd crossover; and,
- Provision of pedestrian path and pram ramps along Aurea Boulevard crossover.

In addition to the above modifications, the following changes have been made to the internal site layout:

- Provision of a turnaround bay within the blind aisle adjacent to the proposed liquor store;
- Shifting the service station canopy and bowsers further west to create more stacking spaces at the bowsers; and,
- Introducing southbound one-way system within the eastern area of the service station forecourt.

As a result of the above modifications, it is recommended that a smaller 17m fuel tankers should be used to service the proposed service station.

With the revised crossover designs, the fuel tanker will enter the site via the Aurea Blvd crossover and exit the site via Thundelarra Drive crossover. Turn path analysis undertaken included in **Appendix B** of this technical note indicates satisfactory movement of the fuel tanker. The turn path analysis also shows satisfactory navigation of the roundabout intersection of Thundelarra Drive/Aurea Blvd by the fuel tanker. To facilitate the left turn, exit of the fuel tanker, a mountable apron is proposed at the Thundelarra Drive crossover.

The Thundelarra Drive crossover now entails a pedestrian refuse. The design of the crossover accommodates left turn outs by the fuel tanker and right and left turn ins by a B99 vehicles as evident from the turn paths in Appendix B.

The turn around bay provided within the blind aisle adjacent to the liquor store will remove the risk of traffic conflicts and congestion within this parking area.

The revised development plan now entails more stacking space behind the fuel bowsers of the proposed service station. This is achieved by shifting the bowsers and the canopy further west yest achieving a 6.5m wide circulation aisle between the parking bays fronting the shop and the bowsers. To further reduce the risk of traffic conflicts, it is recommended that the eastern service station forecourt should be one-way in the southbound direction, but the western forecourt remains as two-way.

3. Conclusions

Following the SAT Mediation, several actions related to development site plan have been actioned resulting in a revised development plan. The revised development plan will result in more efficient traffic circulation within the development reducing the risk of traffic conflicts, queue backs and congestion within the site.

Based on the assessments undertaken by Transcore, it is evident that the revised development plan has successfully addressed all the actions raised and agreed in the mediation. The modifications and adjustments made to the development plan, as guided by the mediation outcomes, have effectively resolved the items discussed during the mediation process.

APPENDIX A

REVISED DEVELOPMENT PLAN



OVERALL AREA (GLAR)	
TENANCY	AREA
FAST FOOD	638.00
CAJON	230.00
SHOPPING SYSTEM	114.00
SPECIALTY	205.00
SUPERMARKET	1185.00
TOTAL GLAR	2402.00

CAR PARKING PROVIDED - OVERALL	
TYPE	COUNT
STANDARD CAR BAY	96
DISABLED BAY	4
ORCHARD PARKING	4
BICYCLE RACKS	15
ACCESS BAYS	2
TOTAL BAYS	121



SITE PLAN
GOLDEN BAY NEIGHBOURHOOD CENTRE

Status: DEVELOPMENT APPLICATION
Path: C:\Users\jsharley\Documents\Bent Local File\2024\4453 - Golden Bay Neighbourhood Centre_2_Aerial.aec

Scale: 1:500 @ A1
North:

Project Number: 44614
Drawing Number: DA101
Revisors: K.
Date: 15.11.23



**DEVELOPMENT
ASSESSMENT PANEL**

APPROVED
12-Mar-2024

APPENDIX B

TURN PATHS



2 Aurea Blvd, Golden Bay
 Austroads 2013: B99 Passenger Car
 B99 left-in

LEGEND
 Vehicle Body
 Wheel Path
 300mm Clearance



t22.035.sk24a
 28/11/2023
 Scale: 1:100 @ A3





2 Aurea Blvd, Golden Bay
 Austroads 2013: B99 Passenger Car
 B99 right-in

LEGEND
 Vehicle Body
 Wheel Path
 300mm Clearance



t22.035.sk25a
 28/11/2023
 Scale: 1:100 @ A3



**DEVELOPMENT
 ASSESSMENT PANEL**
APPROVED
 12-Mar-2024

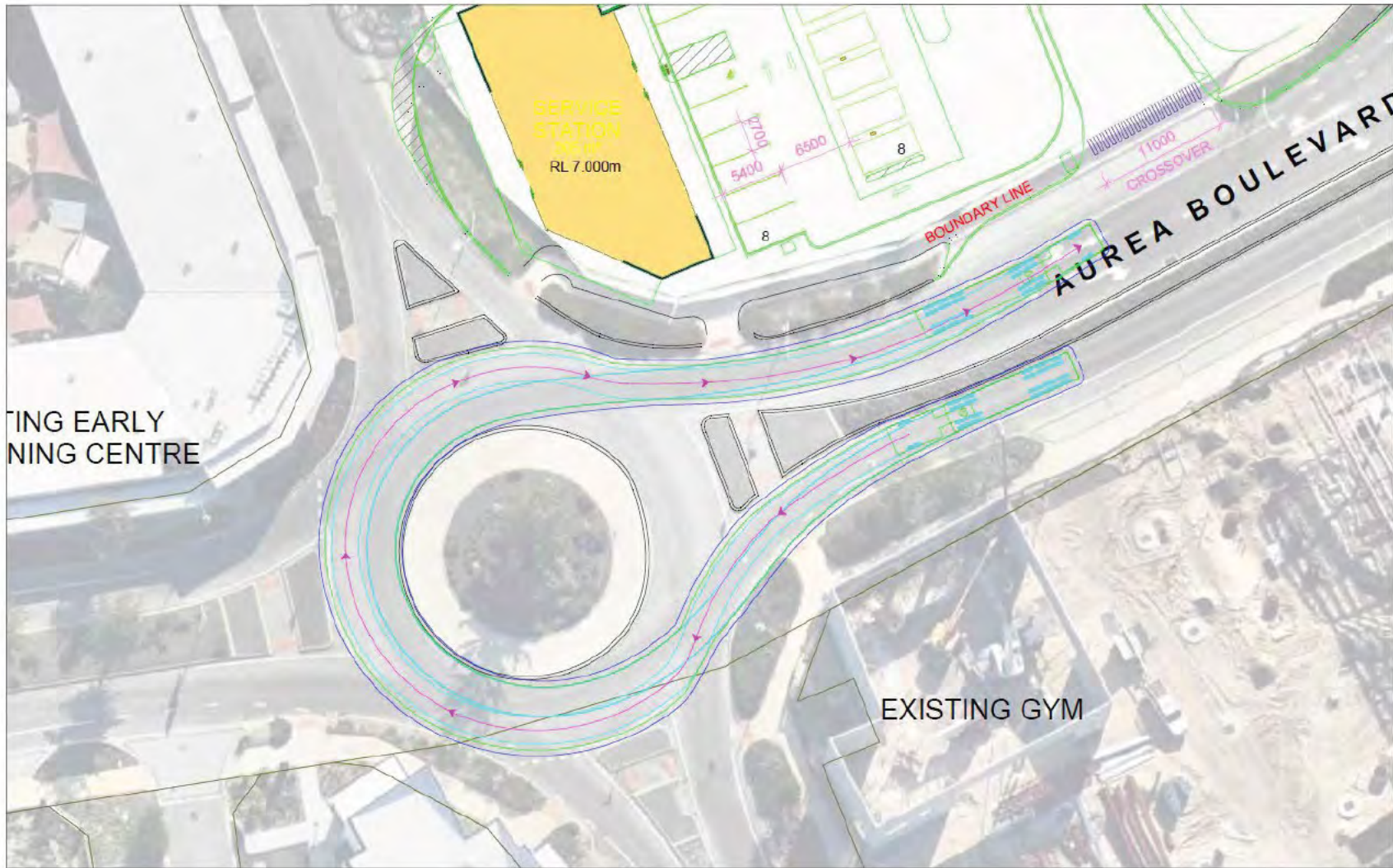

ING EARLY
NING CENTRE

EXISTING GYM

2 Aurea Blvd, Golden Bay
17.0m Fuel-tanker
Fuel tanker U-turn at the roundabout

**DEVELOPMENT
ASSESSMENT PANEL**

APPROVED
12-Mar-2024

LEGEND

- Vehicle Body
- Wheel Path
- 500mm Clearance

t22.035.sk26
28/11/2023
Scale: 1:300 @ A3



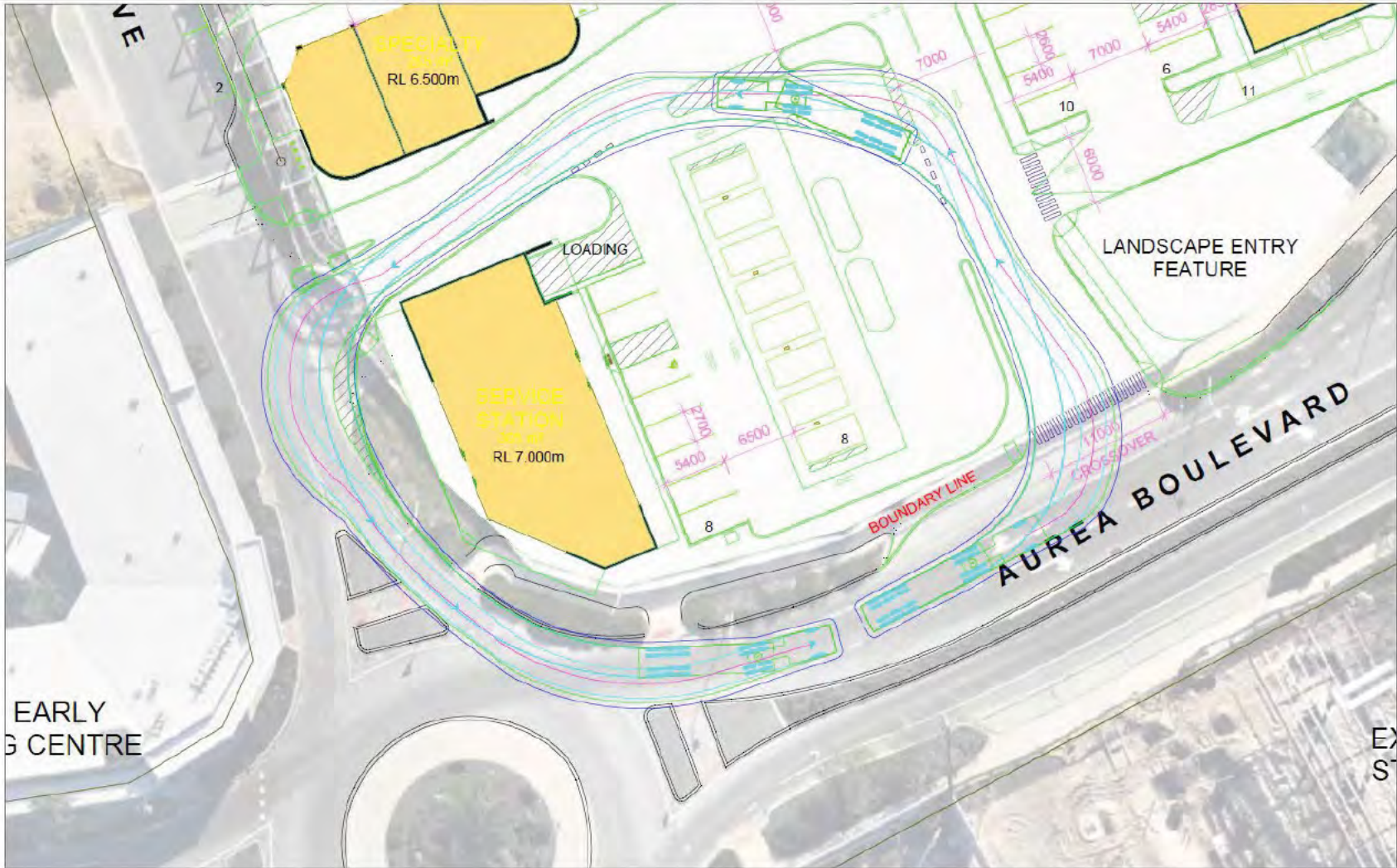

2 Aurea Blvd, Golden Bay
 17.0m Fuel-tanker
 Fuel tanker circulation

LEGEND

- Vehicle Body
- Wheel Path
- 500mm Clearance



t22.035.sk27
 28/11/2023
 Scale: 1:300 @ A3



**DEVELOPMENT
ASSESSMENT PANEL**

APPROVED

12-Mar-2024



DEVELOPMENT
ASSESSMENT PANEL

APPROVED
12-Mar-2024

Lloyd George Acoustics

PO Box 717
Hillarys WA 6923
T: 9401 7770
www.lgacoustics.com.au

Environmental Noise Assessment - Commercial Development

**Golden Bay Neighbourhood Centre,
2 Aurea Blvd, Golden Bay**

Reference: 22117749-01A

Prepared for:
Ladybug Twenty Pty Ltd



Reference: 22117749-01A

Lloyd George Acoustics Pty Ltd

ABN: 79 125 812 544

PO Box 717

Hillarys WA 6923

www.lgacoustics.com.au

Contacts	General	Daniel Lloyd	Terry George	Matt Moyle
E:	info@lgacoustics.com.au	daniel@lgacoustics.com.au	terry@lgacoustics.com.au	matt@lgacoustics.com.au
P:	9401 7770	0439 032 844	0400 414 197	0412 611 330
Contacts	Rob Connolly	Daryl Thompson	Hao Tran	Matt Nolan
E:	rob@lgacoustics.com.au	daryl@lgacoustics.com.au	hao@lgacoustics.com.au	matt.nolan@lgacoustics.com.au
P:	0410 107 440	0420 364 650	0438 481 207	0448 912 604

This report has been prepared in accordance with the scope of services described in the contract or agreement between Lloyd George Acoustics Pty Ltd and the Client. The report relies upon data, surveys, measurements and results taken at or under the particular times and conditions specified herein. Any findings, conclusions or recommendations only apply to the aforementioned circumstances and no greater reliance should be assumed or drawn by the Client. Furthermore, the report has been prepared solely for use by the Client, and Lloyd George Acoustics Pty Ltd accepts no responsibility for its use by other parties.

Date	Rev	Description	Author	Verified
23-Dec-22	0	Draft Issued to Client	Matt Moyle	Terry George
9-Feb-23	-	Finalised Issue	Matt Moyle	Terry George
28-Apr-23	A	Updated IF and Mitigation Recommendations	Matt Moyle	Terry George

CONTENTS

- EXECUTIVE SUMMARY i
- 1. INTRODUCTION 1
- 2. CRITERIA 3
 - 2.1. Regulations 7, 8 & 9 3
 - 2.2. Regulation 3 7
 - 2.3. Regulation 14A 7
- 3. METHODOLOGY 8
 - 3.1. Meteorological Conditions 8
 - 3.2. Topographical Data 8
 - 3.3. Ground Absorption 9
 - 3.4. Source Sound Levels 10
- 4. RESULTS AND ASSESSMENT 11
 - 4.1. Scenario 1 – All Plant and Drive Thru Tenancies L_{A10} 11
 - 4.2. Scenario 2 – Refrigerated Trucks and Full Drive-Through Lanes L_{A1} 12
 - 4.3. Scenario 3 – Night L_{Amax} 13
- 5. RECOMMENDATIONS 17

List of Tables

Table 2-1 Adjustments Where Characteristics Cannot Be Removed	3
Table 2-2 Baseline Assigned Levels	4
Table 2-3 Assigned Levels	6
Table 3-1: Modelling Meteorological Conditions	8
Table 3-2: Source Sound Levels, dB	10
Table 4-1: Scenario 1 Predicted Levels and Assessment, dB L_{A10}	11
Table 4-2: Scenario 2 Predicted Levels and Assessment, dB L_{A1}	12
Table 4-3: Scenario 1 Predicted Levels and Assessment, dB L_{Amax}	13
Table B-1: Percentage of Land Types within 100m and 450m Radii	22
Table B-2: Relevant Roads within 100m and 450m Radii	23
Table B-3: Influencing Factor Calculation, dB	23

List of Figures

Figure 1-1: Subject Site Location (Source: DPLH PlanWA)	1
Figure 1-2: Proposed Site Plan	2
Figure 1-1: Subject Site Location (Source: DPLH PlanWA)	5
Figure 3-1: Overview of Noise Model	9
Figure 4-1: Scenario 1 L_{A1} Noise Contour Plot	14
Figure 4-2: Scenario 2 L_{A1} Noise Contour Plot	15
Figure 4-3: Scenario 3 L_{Amax} Car doors and Air Service Noise Contour Plot	16
Figure B-1: Land Types within 100m and 450m Radii of R2	21

Appendices

Appendix A – Development Plans 18

Appendix B – Influencing Factor Calculation 19

Appendix C – Terminology 24

EXECUTIVE SUMMARY

Lloyd George Acoustics was engaged by Ladybug Twenty Pty Ltd to undertake a noise assessment for a proposed commercial development to be located at Golden Bay Neighbourhood Centre, 2 Aurea Bvd, Golden Bay. This report considered noise emissions from the proposed development to surrounding properties by way of noise modelling. The proposed development is to comprise of a service station, drive-through liquor shop, supermarket, two fast food outlets (with drive-throughs), and minor specialty tenancies. Noise impacts considered include those of mechanical plant, vehicle noise, air service equipment, deliveries and fuel bowsers.

Noise emissions are predicted by way of computer noise modelling and assessed against assigned levels in accordance with the *Environmental Protection (Noise) Regulations 1997*.

The predicted noise levels are demonstrated to be compliant without the need for mitigation measures.

1. INTRODUCTION

Lloyd George Acoustics was engaged by Ladybug Twenty Pty Ltd to undertake an environmental noise assessment of a proposed commercial development to be located at Golden Bay Neighbourhood Centre, 2 Aurea Blvd, Golden Bay (refer *Figure 1-1*) with the site plan shown in *Figure 1-2* and full Development Application (DA) plans provided in *Appendix A*. The development will comprise of the following elements:

- A 24-hour service station and convenience store;
- A liquor tenancy with drive-through lane; and
- A supermarket and three adjacent specialty retail tenancies;
- Two fast food tenancies with drive-through lanes.



Figure 1-1: Subject Site Location (Source: DPLH PlanWA)

The proposed service station will be open 7 days a week, 24-hours a day. The supermarket, liquor tenancy (with drive through) and two fast food tenancies are assumed to operate during the night time period as well. With regard to noise emissions, consideration is given to noise at neighbouring properties from mechanical plant, drive through speakers, air servicing equipment, deliveries, vehicles and fuel bowsers, against the prescribed standards of the *Environmental Protection (Noise) Regulations 1997*.

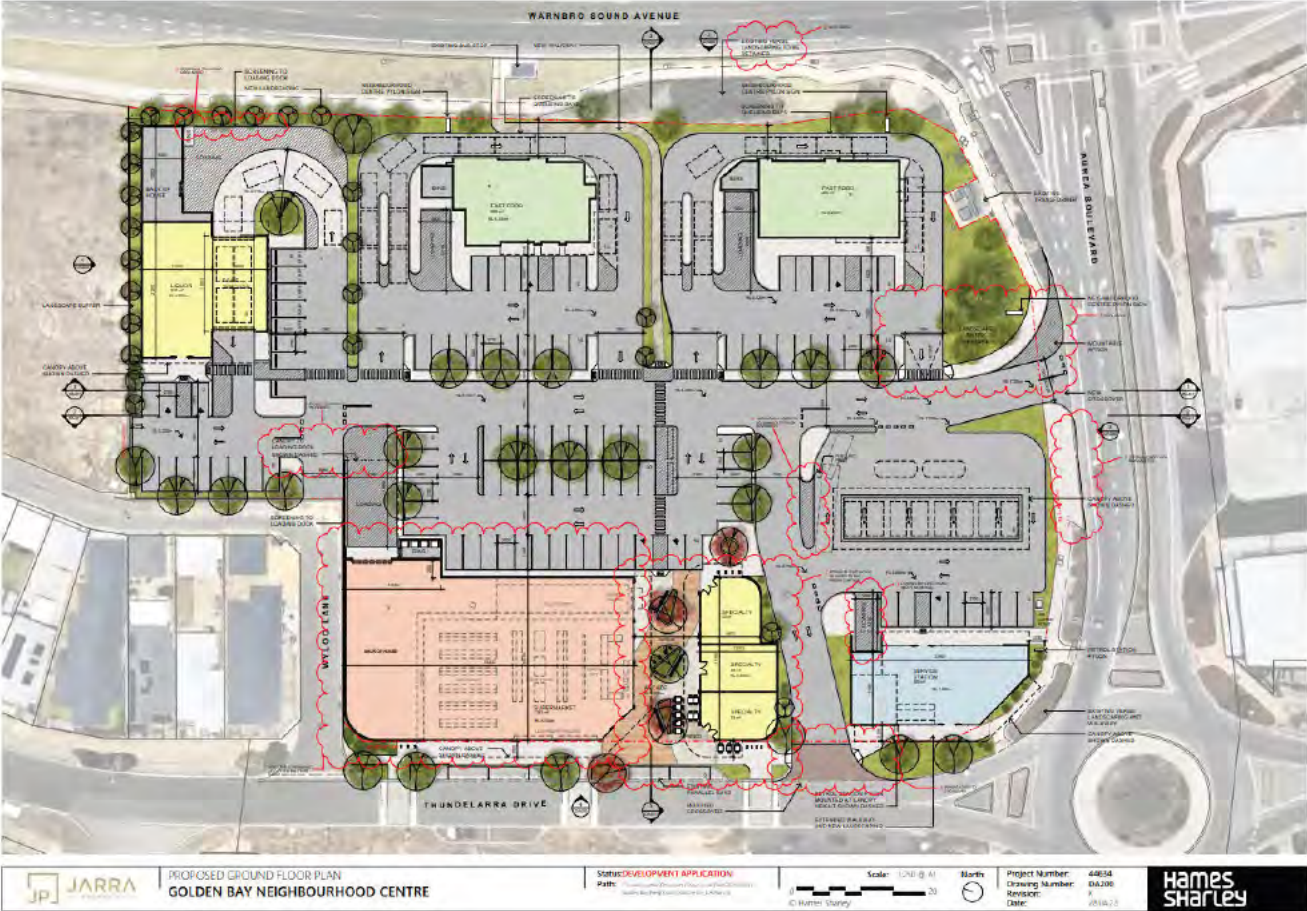

Figure 1-2: Proposed Site Plan

Appendix C contains a description of some of the terminology used throughout this report

2. CRITERIA

Environmental noise in Western Australia is governed by the *Environmental Protection Act 1986*, through the *Environmental Protection (Noise) Regulations 1997* (the Regulations).

2.1. Regulations 7, 8 & 9

This group of regulations provide the prescribed standard for noise as follows:

“7. Prescribed standard for noise emissions

- (1) *Noise emitted from any premises or public place when received at other premises –*
 - (a) *must not cause, or significantly contribute to, a level of noise which exceeds the assigned level in respect of noise received at premises of that kind; and*
 - (b) *must be free of–*
 - (i) *tonality; and*
 - (ii) *impulsiveness; and*
 - (iii) *modulation,**when assessed under regulation 9.*
- (2) *For the purposes of subregulation (1)(a), a noise emission is taken to significantly contribute to a level of noise if the noise emission ... exceeds a value which is 5 dB below the assigned level at the point of reception.”*

Tonality, impulsiveness and modulation are defined in regulation 9 (refer *Appendix C*). Under regulation 9(3), *“Noise is taken to be free of the characteristics of tonality, impulsiveness and modulation if -*

- (a) *the characteristics cannot be reasonably and practicably removed by techniques other than attenuating the overall level of noise emission; and*
- (b) *the noise emission complies with the standard prescribed under regulation 7(1)(a) after the adjustments in the table [Table 2-1] ... are made to the noise emission as measured at the point of reception.”*

Table 2-1 Adjustments Where Characteristics Cannot Be Removed

Where Noise Emission is Not Music*			Where Noise Emission is Music	
Tonality	Modulation	Impulsiveness	No Impulsiveness	Impulsiveness
+ 5 dB	+ 5 dB	+ 10 dB	+ 10 dB	+ 15 dB

* These adjustments are cumulative to a maximum of 15 dB.

The assigned levels (prescribed standards) for all premises are specified in regulation 8(3) and are shown in *Table 2-2*. The L_{A10} assigned level is applicable to noises present for more than 10% of a representative assessment period, generally applicable to “steady-state” noise sources. The L_{A1} is for short-term noise sources present for less than 10% and more than 1% of the time. The L_{Amax} assigned level is applicable for incidental noise sources, present for less than 1% of the time.

Table 2-2 Baseline Assigned Levels

Premises Receiving Noise	Time Of Day	Assigned Level (dB)		
		L_{A10}	L_{A1}	L_{Amax}
Noise sensitive premises: highly sensitive area ¹	0700 to 1900 hours Monday to Saturday (Day)	45 + influencing factor	55 + influencing factor	65 + influencing factor
	0900 to 1900 hours Sunday and public holidays (Sunday)	40 + influencing factor	50 + influencing factor	65 + influencing factor
	1900 to 2200 hours all days (Evening)	40 + influencing factor	50 + influencing factor	55 + influencing factor
	2200 hours on any day to 0700 hours Monday to Saturday and 0900 hours Sunday and public holidays (Night)	35 + influencing factor	45 + influencing factor	55 + influencing factor
Noise sensitive premises: any area other than highly sensitive area	All hours	60	75	80
Commercial Premises	All hours	60	75	80
Industrial and Utility Premises	All hours	65	80	90

¹ *highly sensitive area* means that area (if any) of noise sensitive premises comprising—
(a) a building, or a part of a building, on the premises that is used for a noise sensitive purpose; and
(b) any other part of the premises within 15 metres of that building or that part of the building.

The influencing factor (IF), in relation to noise received at noise sensitive premises, has been calculated as between 2 and 4 dB, as determined in *Appendix B*. *Table 2-3* shows the assigned noise levels including the influencing factor and transport factor at the receiving premises groups shown in *Figure 2-1*.



Figure 1-1: Subject Site Location (Source: DPLH PlanWA)

Table 2-3 Assigned Levels

Premises Receiving Noise	Time Of Day	Assigned Level (dB)		
		L _{A10}	L _{A1}	L _{Amax}
R1, R2, R6 +4 dB IF Noise sensitive premises: highly sensitive area ¹	0700 to 1900 hours Monday to Saturday (Day)	53	63	73
	0900 to 1900 hours Sunday and public holidays (Sunday)	48	58	73
	1900 to 2200 hours all days (Evening)	48	58	63
	2200 hours on any day to 0700 hours Monday to Saturday and 0900 hours Sunday and public holidays (Night)	39	49	63
R3, R4 +5 dB IF Noise sensitive premises: highly sensitive area ¹	0700 to 1900 hours Monday to Saturday (Day)	50	60	70
	0900 to 1900 hours Sunday and public holidays (Sunday)	44	54	70
	1900 to 2200 hours all days (Evening)	44	54	60
	2200 hours on any day to 0700 hours Monday to Saturday and 0900 hours Sunday and public holidays (Night)	40	50	60
R5, R7, R8 Commercial Premises	All hours	60	75	80

It must be noted the assigned levels above apply outside the receiving premises and at a point at least 3 metres away from any substantial reflecting surfaces. Where this was not possible to be achieved due to the close proximity of existing buildings and/or fences, the noise emissions were assessed at a point within 1 metre from building facades and a -2 dB adjustment was made to the predicted noise levels to account for reflected noise.

The assigned levels are statistical levels and therefore the period over which they are determined is important. The Regulations define the Representative Assessment Period (RAP) as "a period of time of not less than 15 minutes, and not exceeding 4 hours, determined by an inspector or authorised person to be appropriate for the assessment of a noise emission, having regard to the type and nature of the noise emission". An inspector or authorised person is a person appointed under Sections 87 & 88 of the *Environmental Protection Act 1986* and include Local Government Environmental Health Officers and Officers from the Department of Water Environmental Regulation. Acoustic consultants or other environmental consultants are not appointed as an inspector or authorised person. Therefore, whilst this assessment is based on a 4-hour RAP, which is assumed to be appropriate given the nature of the operations, this is to be used for guidance only.

2.2. Regulation 3

“3. Regulations do not apply to certain noise emissions

- (1) *Nothing in these regulations applies to the following noise emissions –*
- (a) *Noise emissions from the propulsion and braking systems of motor vehicles operating on a road;”*

The service station car park is considered a road and therefore vehicle noise (propulsion and braking) is not assessed. Noise from vehicle car doors and refrigeration units on trucks however are assessed, since these are not part of the propulsion or braking system. However, vehicle propulsion noise in the drive-through area has been considered assessable in this report due to the nature of the lanes being solely for food ordering purposes and not road access.

It is understood that bulk refuelling at the service station is done during the daytime and gravity fed (no pump) with the engine turned off. As such, this activity is not assessed as noise impact is considered negligible.

2.3. Regulation 14A

“14A. Waste Collection and Other Works

- (2) *Regulation 7 does not apply to noise emitted in the course of carrying out class 1 works if –*
- (a) *The works are carried out in the quietest reasonable and practicable manner; and*
- (b) *The equipment used to carry out the works is the quietest reasonably available;*

class 1 works means specified works carried out between -

- (a) *0700 hours and 1900 hours on any day that is not a Sunday or a public holiday; or*
- (b) *0900 hours and 1900 hours on a Sunday or public holiday.*

specified works means -

- (a) *The collection of waste; or*
- (b) *The cleaning of a road or the drains for a road; or*
- (c) *The cleaning of public places, including footpaths, cycle paths, car parks and beaches;”*

In the case where specified works are to be carried out outside of class 1, a noise management plan is to be prepared and approved by the CEO.

3. METHODOLOGY

Computer modelling has been used to predict the noise emissions from the development. The software used was *SoundPLAN 8.2* with the ISO 9613 algorithms (ISO 17534-3 improved method) selected, as they include the influence of wind and are considered appropriate given the relatively short source to receiver distances. Input data required in the model are listed below and discussed in *Section 3.1* to *Section 3.4*:

- Meteorological Information;
- Topographical data;
- Ground Absorption; and
- Source sound power levels.

3.1. Meteorological Conditions

Meteorological information utilised is provided in *Table 3-1* and is considered to represent worst-case conditions for noise propagation. At wind speeds greater than those shown, sound propagation may be further enhanced, however background noise from the wind itself and from local vegetation is likely to be elevated and dominate the ambient noise levels.

Table 3-1: Modelling Meteorological Conditions

Parameter	Night (7.00pm to 7.00am)
Temperature (°C)	15
Humidity (%)	50
Wind Speed (m/s)	Up to 5
Wind Direction*	All

* The modelling package allows for all wind directions to be modelled simultaneously.

Alternatives to the above default conditions can be used where one year of weather data is available and the analysis considers the worst 2% of the day and night for the month of the year in which the worst-case weather conditions prevail (source: *Draft Guideline on Environmental Noise for Prescribed Premises*, May 2016). In most cases, the default conditions occur for more than 2% of the time and therefore must be satisfied.

3.2. Topographical Data

Topographical data was adapted from publicly available information (e.g. *Google*) in the form of spot heights and combined with the site plan, including a 1.2-metre high parapet around all new buildings.

Surrounding existing buildings were also incorporated in the noise model, as these can provide noise shielding as well as reflection paths. Single storey buildings are modelled with a height of 3.5 metres with receivers 1.4 metres above ground. It is noted that many houses close to the development have laneway type garage access and these are not considered habitable or sensitive facades, so predictions are made to the nearest habitable facades.

Figure 3-1 shows a 2D overview of the noise model with the location of all relevant receivers and noise sources identified. A 3.0m high solid screening wall has also been included to the north of the supermarket loading bay as indicated on DA plans. This is assumed to be minimum 15 kg/m² surface mass and free of gaps. The north boundary fence is assumed to be 1.8m high. A 1.6m high colorbond style (or equivalent) fence is also noted along the north east drive-through liquor lane.



Figure 3-1: Overview of Noise Model

3.3. Ground Absorption

The ground absorption has been assumed to be 0.0 (0%) for the roads and 0.5 (50%) elsewhere, noting that 0.0 represents hard reflective surfaces such as water and 1.0 represents absorptive surfaces such as grass.

3.4. Source Sound Levels

The source sound levels used in the modelling are provided in *Table 3-2*.

Table 3-2: Source Sound Levels, dB

Description	Octave Band Centre Frequency (Hz)								Overall dB(A)
	63	125	250	500	1k	2k	4k	8k	
Fuel Bowsers x 4 – L ₁₀	-	65	68	65	67	65	59	50	71
Air Service Alarm – L _{max}	-	-	-	-	-	91	96	92	99
Refrigeration Condenser Packages – L _{A10}	88	87	85	81	76	70	64	59	82
General Exhaust Fan – L ₁₀	72	70	64	61	53	53	51	45	63
Toilet Exhaust Fan – L ₁₀	-	61	67	61	64	60	52	46	67
Typical AC Condensers – L ₁₀	-	77	75	72	70	67	62	56	75
Pulford Silenced Compressor – L ₁₀	73	72	75	71	67	63	59	51	73
Ice Box Compressor – L ₁₀	51	61	61	63	63	59	56	47	68
Car Door Closings – L _{max}	71	74	77	81	80	78	72	61	84
Large Refrigerated Truck Condenser – L ₁	88	79	92	90	92	91	85	76	98
Drive-Through Speaker – L _{A1}	62	64	66	77	80	73	57	42	82
Drive-Through Car Idling – L _{A10}	81	78	74	72	74	74	67	64	79

The following is noted in relation to *Table 3-2*:

- Mechanical plant sound levels are estimated from previous projects;
- Exhaust fans are located 0.5m above roof;
- The Pulford Compressor is located in the service yard of the service station, 1.0m above ground level;
- A/C plant (Condensers) for all stores are located on the rooftop (1.0m above roof level) and screened with parapets;
- The Ice Box is located at the front of the convenience store, 1.8m above ground level;
- Fuel bowsers, air service alarm and car doors are modelled as 1.0m above ground level;
- Refrigerated truck condenser is modelled at 2.3m above ground;
- Car door and all engine sources are modelled at 0.5m above ground;
- For each of the three drive through tenancies, 5 to 10 vehicles are modelled idling in the Drive-Through queuing, ordering and waiting areas, depending on the calculation scenario (see below).

4. RESULTS AND ASSESSMENT

Noise modelling was undertaken for the following scenarios:

- Night-time (L_{A10}) – Includes all L_{A10} noise sources of *Table 3-2*, with a total of 15 idling cars in drive through lanes (5 per tenancy);
- Night-time (L_{A1}) – Includes a refrigerated delivery truck in each loading area (cold deliveries) and 30 cars in drive through lanes (10 per tenancy) and the drive through speakers of both fast food outlets;
- Night-time (L_{Amax}) – Considers car door closings and air service alarm.

4.1. Scenario 1 – All Plant and Drive Thru Tenancies L_{A10}

The results for night-time operations are provided in *Table 4-1*. A noise contour plot is also provided in *Figure 4-1* showing noise levels at ground floor. It should be noted that the assessment has assumed all fuel plant including fuel bowsers will be used simultaneously during the night, which is conservative as they will generally cycle intermittently.

Table 4-1: Scenario 1 Predicted Levels and Assessment, dB L_{A10}

Receiver	Fuel Bowsers	All Mech Plant	15 Drive Through Vehicles	Total	Night Assigned Noise Level	Assessment
R1 6 Elvire Gr (west houses)	17	25	25	28	39	Complies
R1 24 Elvire Gr (west houses)	14	27	27	30	39	Complies
R1 97 Thundelarra Dr	12	28	20	29	39	Complies
R2 90-92 Thundelarra Dr	13	36	36	39	39	Complies
R2 Lot 9505 North	18	31	33	35	39	Complies
R3 12 Mallina Cr (Res NE)	21	25	38	38	40	Complies
R4 38 Winderie Rd (Future Res)	22	24	36	36	40	Complies
R5 Lot 265 South (Commercial)	31	28	33	36	60	Complies
R6 15 Aurea Bvd (CCC)	25	26	28	31	39	Complies
R6 17 Aurea Bvd (south housing)	20	25	24	28	39	Complies
R6 20 Aurea Bvd (Comm CCC)	28	33	31	36	39	Complies
R7 95 Thundelarra Dr (Vacant)	27	33	29	35	60	Complies
R8 Lot 9037 Future Comm	17	28	41	41	60	Complies

The mechanical plant and vehicles in drive through lanes are the dominant sources and given the number and range of sources operating simultaneously in this scenario, tonality of the mechanical plant is not considered

detectable. Therefore, the predicted level is compliant at all the worst-case locations. Note compliance is still achieved even if the + 5 dB tonality adjustment was applied to the mechanical plant noise only.

As the analysis is based on file data, it is recommended that a follow up verification of mechanical plant selections be carried out at detailed design by a suitably qualified acoustical consultant.

4.2. Scenario 2 – Refrigerated Trucks and Full Drive-Through Lanes L_{A1}

The predicted noise levels from all four refrigerated delivery trucks and the fully loaded drive through lanes are provided in *Table 4-2*. A noise contour plot is also provided in *Figure 4-2* showing noise levels at ground floor. This assumes deliveries will take less than 24 minutes in a 4-hour period, which is considered sufficient time for a scale stores. It should also be noted that it is unlikely that all four stores will be receiving deliveries simultaneously, and during peak drive through usage, therefore the assessment is to be considered as a conservative worst-case scenario.

Table 4-2: Scenario 2 Predicted Levels and Assessment, dB L_{A1}

Receiver	4 Delivery Trucks	30 Drive Through Vehicles	Total [#]	Night-time Assigned Noise Level	Assessment
R1 6 Elvire Gr (west houses)	36	29	37	49	Complies
R1 24 Elvire Gr (west houses)	32	32	35	49	Complies
R1 97 Thundelarra Dr	30	24	33	49	Complies
R2 90-92 Thundelarra Dr	44	41	46	49	Complies
R2 Lot 9505 North	48	37	48	49	Complies
R3 12 Mallina Cr (Res NE)	45	43	47	50	Complies
R4 38 Winderie Rd (Future Res)	42	40	44	50	Complies
R5 Lot 265 South (Commercial)	48	37	49	75	Complies
R6 15 Aurea Bvd (CCC)	39	32	40	49	Complies
R6 17 Aurea Bvd (south housing)	33	28	35	49	Complies
R6 20 Aurea Bvd (Comm CCC)	43	35	44	49	Complies
R7 95 Thundelarra Dr (Vacant)	40	32	42	75	Complies
R8 Lot 9037 Future Comm	42	46	47	75	Complies

[#]Includes all Mech Plant Sources from Scenario 1

Compliance at all receivers is predicted at night and therefore mitigation measures are not required. Note that with the number of vehicle sources (including 4 delivery trucks) present in the scenario, it is unlikely that tonality would be detectable in the L_{A1} measured level. Note also that some sensitive receivers are identified as Childcare Centres (CCC) and would likely be unoccupied during the evening and night time periods.

4.3. Scenario 3 – Night L_{Amax}

The results for night-time L_{Amax} scenario (car doors and air service alarm) are provided in *Table 4-3*. A noise contour plot (non-cumulative) is also provided in *Figure 4-3* showing noise levels at ground floor. Car door closing noise levels are adjusted by + 10 dB for impulsiveness and air service alarms adjusted by + 5 dB for tonality and assessed against the night-time L_{Amax} assigned level.

Table 4-3: Scenario 1 Predicted Levels and Assessment, dB L_{Amax}

Receiver	Air Service Alarm*	Car Door Closing#	Maximum	Assigned Noise Level	Assessment
R1 6 Elviré Gr (west houses)	24	41	41	61	Complies
R1 24 Elviré Gr (west houses)	25	39	39	61	Complies
R1 97 Thundelarra Dr	27	29	29	61	Complies
R2 90-92 Thundelarra Dr	23	39	39	63	Complies
R2 Lot 9505 North	39	57	57	63	Complies
R3 12 Mallína Cr (Res NE)	45	43	45	62	Complies
R4 38 Winderie Rd (Future Res)	47	40	47	62	Complies
R5 Lot 265 South (Commercial)	59	50	59	80	Complies
R6 15 Aurea Bvd (CCC)	54	44	54	62	Complies
R6 17 Aurea Bvd (south housing)	50	41	50	61	Complies
R6 20 Aurea Bvd (Comm CCC)	32	48	48	63	Complies
R7 95 Thundelarra Dr (Vacant)	31	50	50	80	Complies
R8 Lot 9037 Future Comm	40	43	43	80	Complies

* Adjusted by + 5 dB for tonality

Adjusted by + 10 dB for impulsiveness

Noise levels are predicted to comply at all receivers, inclusive of the tonality or impulsiveness adjustment. As discussed in *Section 3.2*, it is noted that residences across Wyloo Lane have garages facing the new parking bays of the liquor store tenancy and therefore the facades are not considered highly noise sensitive.

Figure 4-1 Scenario 1 Noise Ground Floor, dB LA10



Predicted Noise level

█	= 36
█	= 41
█	= 46
█	= 51
█	= 56

Legend

- Receiver
- ✱ Car/Mech Source
- 1.8m fence
- 3.0m Noise Wall
- 1.6m fence

**DEVELOPMENT
ASSESSMENT PANEL**

APPROVED

12-Mar-2024



Scale 1:1300



Project No: 22117749
 Consultant: MM
 Date: 28/04/2023
 Algorithm: ISO 9613
 SoundPLAN Version: 8.2



Lloyd George Acoustics
 PO Box 717
 HILLARYS WA 6923
 (08) 9401 7770

Figure 4-2 Scenario 2 Noise Ground Floor, dB LA1



Predicted Noise level

█	= 46
█	= 51
█	= 56
█	= 61
█	= 66

Legend

- Receiver
- ✱ Car/Mech Source
- 1.8m fence
- 3.0m Noise Wall
- 1.6m fence
- ▭ Delivery Truck

**DEVELOPMENT
ASSESSMENT PANEL**

APPROVED

12-Mar-2024



Scale 1:1300



Project No: 22117749
 Consultant: MM
 Date: 28/04/2023
 Algorithm: ISO 9613
 SoundPLAN Version: 8.2



Lloyd George Acoustics
 PO Box 717
 HILLARYS WA 6923
 (08) 9401 7770

Figure 4-3 Scenario 3 Noise Ground Floor, dB L_{Amax}

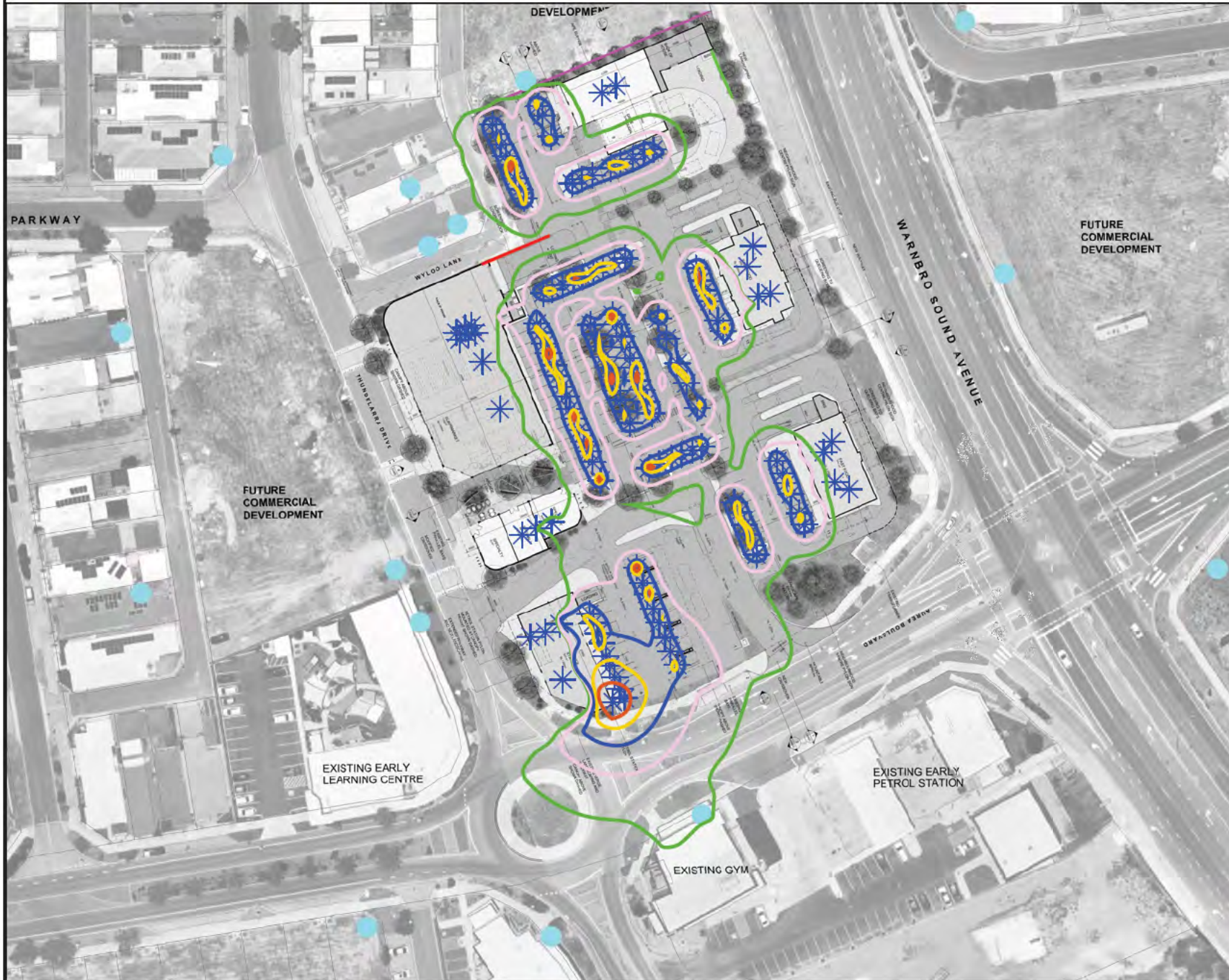

Predicted Noise level

█	= 56
█	= 61
█	= 66
█	= 71
█	= 76

Legend

- Receiver
- ✱ Car/Mech Source
- 1.8m fence
- 3.0m Noise Wall
- 1.6m fence

DEVELOPMENT
ASSESSMENT PANEL

APPROVED

12-Mar-2024



Scale 1:1300



Project No: 22117749
 Consultant: MM
 Date: 28/04/2023
 Algorithm: ISO 9613
 SoundPLAN Version: 8.2



Lloyd George Acoustics
 PO Box 717
 HILLARYS WA 6923
 (08) 9401 7770

5. RECOMMENDATIONS

The assessment has demonstrated that noise from the mixed commercial development can comply with the assigned levels determined in accordance with the *Environmental Protection (Noise) Regulations 1997* without the need for mitigation measures.

The 3.0m high screen wall to the loading bay is to extend the length of the loading bay as shown on DA plans, to be of solid construction (no gaps) and of a material with minimum surface mass 15 kg/m². The carport structure overhead should extend at least 4 metres across, be lined with an absorptive material such as anti-con insulation and no gaps should exist between overhead section and vertical screen wall.

To ensure compliance with the noise regulations, delivery vehicles are to have broadband type reversing alarms fitted rather than standard tonal alarms. This is also inline with the guidance provided by DWER and considered less likely to elicit complaints from the community.

An additional section of solid screening is to be constructed near the liquor store bin area, of minimum height 1.6m and of minimum surface mass 4 kg/m² and free of gaps.

While not required for compliance, noting that the development is at DA stage only, some best practice recommendations have been included below though – to be implemented in the design and operation where practicable:

- Any external music or the like shall be low level and inaudible at residences;
- Bin servicing shall occur between 7.00am and 7.00pm Mondays to Saturdays. The servicing of bins would fall under Regulation 14A and provided it is carried out within the stipulated hours and undertaken as quietly as reasonably practicable, the 'normal' assigned levels do not apply. Where possible, bins shall be located in areas away from and/or screened from residences. Where this activity also includes truck reversing alarm noise, this would be considered exempt under Regulation 14A within the stipulated hours.
- Access grates or similar to be plastic or metal with rubber gasket and secured to avoid excess banging.
- All refrigerated delivery drivers attending the site at night are to make all effort to deliver quietly, leave promptly, and not idle trucks on site for longer than necessary.
- Mechanical plant:
 - Once the mechanical plant has been designed and selected, the noise levels shall be reviewed prior to Building Permit;
 - All exhaust fans shall be located inside the ceiling void and shall be axial fan type, allowing the incorporation of an attenuator if required;
 - All fans shall be variable speed drive so that maximum speed is only occurring when necessary with demand;
 - Air-conditioning shall have a 'night' / 'quiet' mode option, in case required for prior to 7.00am operation, subject to final detailed analysis;
 - All plant shall be selected for quiet operation;
 - All plant is to be appropriately vibration isolated to 95% isolation efficiency.

Appendix A – Development Plans

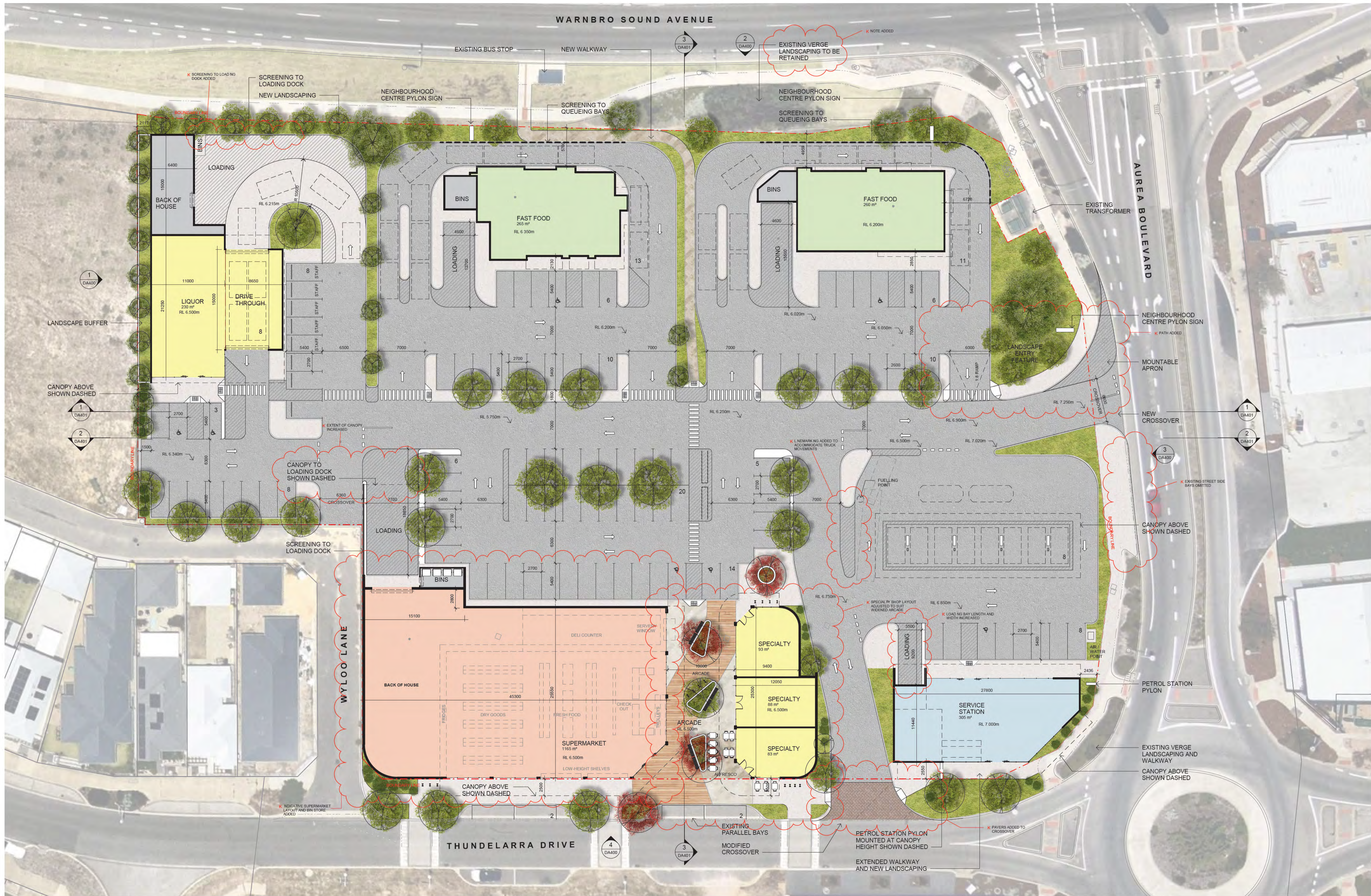

Appendix B – Influencing Factor Calculation

The assigned levels combine a baseline assigned level with an influencing factor, with the latter increasing the assigned level on the basis of the existence of significant roads and commercial or industrial zoned land within an inner circle (100 metre radius) and an outer circle (450 metre radius) of the noise sensitive premises. The calculation for the influencing factor is:

$$= \frac{1}{10} (\% \text{ Type A}_{100} + \% \text{ Type A}_{450}) + \frac{1}{20} (\% \text{ Type B}_{100} + \% \text{ Type B}_{450})$$

where :

% Type A₁₀₀ = the percentage of industrial land within
a 100m radius of the premises receiving the noise

% Type A₄₅₀ = the percentage of industrial land within
a 450m radius of the premises receiving the noise

% Type B₁₀₀ = the percentage of commercial land within
a 100m radius of the premises receiving the noise

% Type B₄₅₀ = the percentage of commercial land within
a 450m radius of the premises receiving the noise

+ Transport Factor (maximum of 6 dB)

= 2 for each secondary road (6,000 to 15,000 vpd) within 100m

= 2 for each major road (> 15,000 vpd) within 450m

= 6 for each major road within 100m

The nearest noise sensitive and commercial premises are identified as:

- R1 6 Elvire Gr (west houses)
- R1 24 Elvire Gr (west houses)
- R1 97 Thundelarra Dr
- R2 90-92 Thundelarra Dr
- R2 Lot 9505 North
- R3 12 Mallina Cr (Res NE)
- R4 38 Winderie Rd (Future Res)
- R5 Lot 265 South (Commercial)
- R6 15 Aurea Bvd (CCC)
- R6 17 Aurea Bvd (south housing)
- R6 20 Aurea Bvd (Comm CCC)
- R7 95 Thundelarra Dr (Vacant)
- R8 Lot 9037 Future Commercial

Table B-1 shows the percentage of industrial and commercial land within the inner (100 metre radius) and outer (450 metre radius) circles of the noise sensitive premises, with this also shown on Figure B-1 for Receiver R2.



Figure B-1: Land Types within 100m and 450m Radii of R2

Table B-1: Percentage of Land Types within 100m and 450m Radii

Receiver	Land Type	Within 100m	Within 450m
R1, R6	Type A - Industrial and Utility	0	0
	Type B – Commercial	26	5
R2	Type A - Industrial and Utility	0	0
	Type B – Commercial	43	5
R3, R4	Type A - Industrial and Utility	0	0
	Type B – Commercial	25	5

The Main Roads WA Traffic Map does provide current traffic counts in this area (Feb 2022 LM01072) with counts in the order of 10,000 vpd. However with knowledge of the planning framework since 2011, information has been obtained from Main Roads WA *Perth Metropolitan Functional Road Hierarchy 1997*, referring to Warnbro Sound Avenue as a Distributor A or Arterial road with intent to carry 15,000 to 35,000 vpd. The same document classifies Auera Boulevard as a Local Distributor with a maximum 6,000 vpd. It is clear that the roads have been designed and planned for high vehicle use in this commercial and residential hub since 2011. Despite these classifications, the Noise Regulations require recent traffic counts to be used when classifying the road for purposes of determining a transport factor. *Table B-2* shows the relevant roads and their traffic estimates within the inner (100 metre radius) and outer (450 metre radius) circles.

Table B-2: Relevant Roads within 100m and 450m Radii

Receiver	Within 100m		Within 450m
	Major Road (+ 6 dB)	Secondary Road (+ 2 dB)	Major Road Not Within 100m (+ 2 dB)
R1, R6	-	Auera Bvd Local Distributor (6K Vpd)	-
R2	-	Warnbro Sound Ave (10K Vpd)	-
R3, R4	-	Warnbro Sound Ave (10K Vpd)	-

Table B-3 combines the percentage land types and Transport Factor to calculate the influencing factor.

Table B-3: Influencing Factor Calculation, dB

Receiver	Industrial Land	Commercial Land	Transport Factor	Total
R1, R6	0.0	1.5	2	4
R2	0.0	2.3	2	4
R3, R4	0.0	1.4	2	3

The influencing factor calculated in *Table B-3* is combined with those baseline assigned levels of *Table 2-2*, resulting in the project assigned levels provided in *Table 2-3*.

Appendix C – Terminology

The following is an explanation of the terminology used throughout this report:

- **Decibel (dB)**

The decibel is the unit that describes the sound pressure levels of a noise source. It is a logarithmic scale referenced to the threshold of hearing.

- **A-Weighting**

An A-weighted noise level has been filtered in such a way as to represent the way in which the human ear perceives sound. This weighting reflects the fact that the human ear is not as sensitive to lower frequencies as it is to higher frequencies. An A-weighted sound level is described as L_A , dB.

- **Sound Power Level (L_w)**

Under normal conditions, a given sound source will radiate the same amount of energy, irrespective of its surroundings, being the sound power level. This is similar to a 1kW electric heater always radiating 1kW of heat. The sound power level of a noise source cannot be directly measured using a sound level meter but is calculated based on measured sound pressure level at known distances. Noise modelling incorporates source sound power levels as part of the input data.

- **Sound Pressure Level (L_p)**

The sound pressure level of a noise source is dependent upon its surroundings, being influenced by distance, ground absorption, topography, meteorological conditions etc. and is what the human ear actually hears. Using the electric heater analogy above, the heat will vary depending upon where the heater is located, just as the sound pressure level will vary depending on the surroundings. Noise modelling predicts the sound pressure level from the sound power levels taking into account ground absorption, barrier effects, distance etc.

- **L_{ASlow}**

This is the noise level in decibels, obtained using the A-frequency weighting and the S (slow) time weighting. Unless assessing modulation, all measurements use the slow time weighting characteristic.

- **L_{AFast}**

This is the noise level in decibels, obtained using the A-frequency weighting and the F (fast) time weighting. This is used when assessing the presence of modulation.

- **L_{APeak}**

This is the greatest absolute instantaneous sound pressure level in decibels using the A-frequency weighting.

- **L_{Amax}**

An L_{Amax} level is the maximum A-weighted noise level during a particular measurement.

- **L_{A1}**

The L_{A1} level is the A-weighted noise level exceeded for 1 percent of the measurement period and is considered to represent the average of the maximum noise levels measured.

- **L_{A10}**

The L_{A10} level is the A-weighted noise level exceeded for 10 percent of the measurement period and is considered to represent the “intrusive” noise level.

- **L_{A90}**

The L_{A90} level is the A-weighted noise level exceeded for 90 percent of the measurement period and is considered to represent the “background” noise level.

- **L_{Aeq}**

The equivalent steady state A-weighted sound level (“equal energy”) in decibels which, in a specified time period, contains the same acoustic energy as the time-varying level during the same period. It is considered to represent the “average” noise level.

- **One-Third-Octave Band**

Means a band of frequencies spanning one-third of an octave and having a centre frequency between 25 Hz and 20000 Hz inclusive.

- **Representative Assessment Period**

Means a period of time not less than 15 minutes, and not exceeding four hours, determined by an inspector or authorised person to be appropriate for the assessment of a noise emission, having regard to the type and nature of the noise emission.

- **L_{Amax} assigned level**

Means an assigned level, which, measured as a L_{ASlow} value, is not to be exceeded at any time.

- **L_{A1} assigned level**

Means an assigned level, which, measured as a L_{ASlow} value, is not to be exceeded for more than 1 percent of the representative assessment period.

- **L_{A10} assigned level**

Means an assigned level, which, measured as a L_{ASlow} value, is not to be exceeded for more than 10 percent of the representative assessment period.

• Tonal Noise

A tonal noise source can be described as a source that has a distinctive noise emission in one or more frequencies. An example would be whining or droning. The quantitative definition of tonality is:

- the presence in the noise emission of tonal characteristics where the difference between -
 - (a) the A-weighted sound pressure level in any one-third octave band; and
 - (b) the arithmetic average of the A-weighted sound pressure levels in the 2 adjacent one-third octave bands,

is greater than 3 dB when the sound pressure levels are determined as $L_{Aeq,T}$ levels where the time period T is greater than 10% of the representative assessment period, or greater than 8 dB at any time when the sound pressure levels are determined as $L_{A\ Slow}$ levels.

This is relatively common in most noise sources.

• Modulating Noise

A modulating source is regular, cyclic and audible and is present for at least 10% of the measurement period. The quantitative definition of modulation is:

- a variation in the emission of noise that —
 - (a) is more than 3 dB $L_{A\ Fast}$ or is more than 3 dB $L_{A\ Fast}$ in any one-third octave band; and
 - (b) is present for at least 10% of the representative assessment period; and
 - (c) is regular, cyclic and audible.

• Impulsive Noise

An impulsive noise source has a short-term banging, clunking or explosive sound. The quantitative definition of impulsiveness means:

- a variation in the emission of a noise where the difference between L_{Apeak} and L_{Amax} is more than 15 dB when determined for a single representative event.

• Major Road

Is a road with an estimated average daily traffic count of more than 15,000 vehicles.

• Secondary / Minor Road

Is a road with an estimated average daily traffic count of between 6,000 and 15,000 vehicles.

• Chart of Noise Level Descriptors

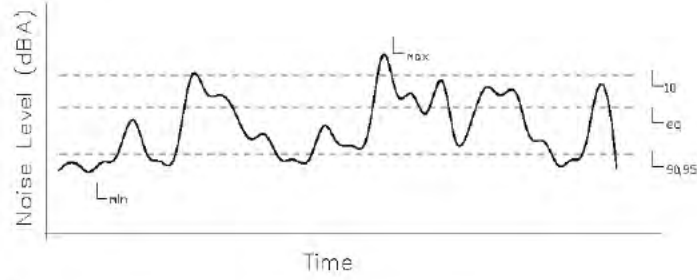

• Austroads Vehicle Class

VEHICLE CLASSIFICATION SYSTEM	
AUSTRADS	
CLASS	VEHICLE
LIGHT VEHICLES	
1	Motorcycle 125cc and below, 125cc 125cc Motorbicycle
2	Light Vehicle Motor Car, Light Truck
HEAVY VEHICLES	
3	Tractor Trailer Unit Tractor
4	Tractor Trailer Unit Tractor Trailer Unit
5	Tractor Trailer Unit Tractor Trailer Unit
6	Tractor Trailer Unit Tractor Trailer Unit
7	Tractor Trailer Unit Tractor Trailer Unit
8	Tractor Trailer Unit Tractor Trailer Unit
9	Tractor Trailer Unit Tractor Trailer Unit
LONG VEHICLES AND ROAD TRUCKS	
10	Tractor Trailer Unit Tractor Trailer Unit
11	Tractor Trailer Unit Tractor Trailer Unit
12	Tractor Trailer Unit Tractor Trailer Unit

• Typical Noise Levels

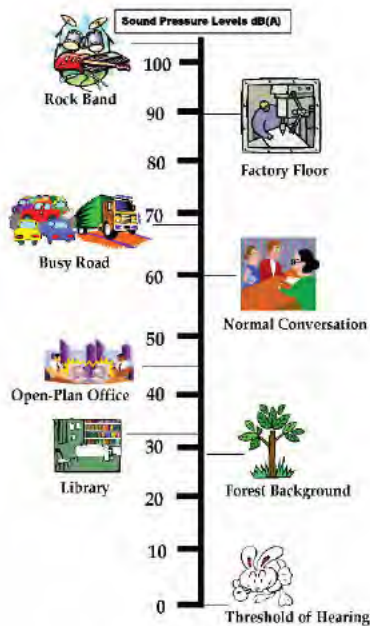



EMISSIONS IMPACT ASSESSMENT OF PROPOSED 24HR FUEL SERVICE STATION

**LOT 622, (2) AUREA BOULEVARD,
GOLDEN BAY WESTERN AUSTRALIA**

DEVELOPMENT
ASSESSMENT PANEL

APPROVED
22-Mar-2024



Emissions Impact Assessment of Proposed 24Hr Fuel Service Station

Lot 622, (2) Aurea Boulevard, Golden Bay Western Australia

Prepared for: Golden Bay Neighbourhood Centre

Project Ref: EAQ-22031
December 2023



Environment | Air Quality





Environmental & Air Quality Consulting Pty Ltd
PO Box 897
JOONDALUP DC
WA 6919
+61 (8) 6108 3760
+61 (0) 449 915 043
www.eaqconsulting.au
jhurley@eaqconsulting.com.au

Report Revision(s)

Version(s)	Description	Date	Author(s)	Reviewer(s)
Draft_0.1	Internal Review	13.12.2022	J. Hurley	DSB
Draft_1.0	Draft Report	13.12.2022	J. Hurley	Golden Bay Neighbourhood Centre
Draft_1.1	Draft Report	14.03.2023	J. Hurley	Golden Bay Neighbourhood Centre
Final	Final Report	21.12.2023	J. Hurley	

Approved for Release

Name	Position	File Reference
John Hurley	Principal Consultant	EAQ22031-GoldenBayServiceStation+EmissionsImpactAssessment-Final

Signature

This document, its content and intellectual property is the property of Environmental & Air Quality Consulting Pty Ltd (EAQ). The document may only be used for the purposes for which it was commissioned. Distribution of this document in full, or part thereof is not permitted without the permission of EAQ and/or the Client. Unauthorised copying or use of this document is prohibited.

This document presents the outcomes of a Desktop Emissions Modelling Assessment. All emissions inputs into the model were sourced from previous site-specific measurements, from peer reviewed public domain data and/or industry specific emissions' factor publications except where detailed otherwise herein. EAQ has not attempted to verify externally sourced data beyond its use herein. The modelling assessment has been prepared using the best available information provided by the Client and in conjunction with regulatory guidance from the appropriate regulatory jurisdiction(s). EAQ has exercised its diligence and due-care in delivering the outcomes of the assessment according to accepted assessment practices and techniques. EAQ disclaims any and all liability and responsibilities for damages of any nature, to any party, which may be caused from misapplication or misinterpretation by third parties of this assessment





Contents

Executive Summary	6
1 Background & Scope	10
1.1 Assessment Scope.....	10
1.1.1 Legislative Context	11
1.1.2 Assessment Substances	11
1.2 Guidance for Assessing Impacts	12
1.3 The Site	12
2 Emission Estimation	17
2.1 Bulk Deliveries and Emissions.....	17
2.2 VOC Emissions.....	18
2.3 Site Operational Data.....	19
2.4 Derived Emission Factors.....	19
2.4.1 Fuel Throughput Trends	20
2.4.2 Cumulative Emissions Impacts	22
3 Aermom Dispersion Modelling Methods.....	23
3.1 Meteorology	23
3.2 Sensitive Receptors.....	23
3.3 Building Profile Input Program (BPIP).....	23
3.4 Dispersion Modelling Limitations	23
4 Assessment Results & Discussion.....	24
5 Additional Information - Ambient BTEX Sampling.....	28
5.1 Ambient BTEX Sampling Conclusions.....	30
Appendix A: Emissions Calculations	31
Appendix B: Example of AERMOD Input File.....	32





Figures

Figure 1-1: Proposed 24-hr Golden Bay Service Station (assessed).....	14
Figure 1-2: Lot 622 (2) Aurea Boulevard, Golden Bay Western Australia.....	15
Figure 1-3: Modelling Depiction of Site Layout (Proposed) and Adjacent site (Approved).....	16
Figure 5-1: Wind Characteristics during SUMMA Cannister Sampling.	29

Tables

Table 1-1: WA EPA Guidance for Separation Distances	11
Table 1-2: Assessment Substances (pollutants)	11
Table 1-3: Assessment Criteria for Toxic Substances	12
Table 2-1: Example of Bulk Fuel Delivery Schedule (L/hr).....	18
Table 2-2: Composition of Petrol (NPI, 1999).....	18
Table 2-3: Proposed Site Operating Detail	19
Table 2-4: Emissions Factors for Service Stations	19
Table 2-5: Representative Fuel Throughputs (BCC, 2017)	20
Table 2-6: Factored Total VOC Emission Rates per Hour (VR1 + VR2)	21
Table 2-7: Summary of Proposed Site’s Fuel Service Station Emissions	21
Table 2-8: Adjacent service station site’s operational data	22
Table 2-9: Summary of Adjacent site’s Fuel Service Station Emissions	22
Table 4-1: Proposed Site - Assessment Results for GLC’s of Pollutants (VR1 & VR2) @ Nearest Urban Dwellings.....	25
Table 4-2: Proposed Site & Adjacent site – CUMULATIVE Assessment Results for GLC’s of Pollutants (VR1 & VR2) @ Nearest Urban Dwellings	26
Table 4-3: Proposed Site & Adjacent site – CUMULATIVE Assessment Results for GLC’s of Pollutants (VR1 & VR2) @ Childcare Facilities	26
Table 5-1: BTEX Sampling Results.....	28
Table 5-2: Derived Ambient Benzene Concentrations	30



Executive Summary

Environmental and Air Quality Consulting Pty Ltd undertook an Air Emissions Assessment of a proposed 24-hour Fuel Service Station to be located at Lot 622, (2) Aurea Boulevard, Golden Bay Western Australia.

The site-specific scientific study addressed the short-term exposure and long-term health risks associated with vapour emissions from the Fuel Service Station as they relate to existing and adjacent childcare centres within the locality.

The Fuel Service Station is within an urban developed area and is part of an overall commercial development site which includes adjacent commercial activities to include an existing 7-Eleven service station that is located on the opposite side of Aurea Boulevard.

The Assessment utilised industry accepted standards for estimating pollutant emission rates of primary airborne pollutants from fuel storage and refuelling activities at the Fuel Service Station and assessed these pollutant emission rates utilising conventional dispersion modelling methods to predict the concentration of primary pollutants at the nearest sensitive receiver within the locality.

Additionally, the Assessment addressed cumulative emissions' impacts from the adjacent service station.

Primary Assessment Conservatism

The primary Assessment conservatisms were:

- Estimated daily refuelling volume used 26,610 L, which is markedly above adjacent 7-Eleven average daily refuelling volume of 13,800 L, and the industry average for suburban sites of approx. 9,000L per day;
- The maximum volume of fuel delivered per hour utilised is 60,000 L, however; the maximum size of a semi-trailer that can deliver fuel to this site has a capacity of less than 40,000 L;
- The modelled fuel delivery schedule assumed up to 180,000 L of fuel deliveries per day (4.5 x higher than expected on a delivery day) and 960,000 L of fuel deliveries per week (more than 8x higher than expected per week). This was done to account for variability in daily and weekly hours where deliveries may be made to the Fuel Service Station;
- The percentage (%) composition of benzene used in the modelling Assessment was 2.9 % (Table 2-2) which was reflective of the NPI 1999 standard. However, the maximum % of benzene in fuel sold in Australia is limited to a maximum of 1% v/v by the *Fuel Standard (Petrol Determination) 2019* made under s.21 of the *Fuel Quality Standards Act 2000 (Cth)*;
- All fuel throughput in the model has been assumed to be ULP even though it is expected that 22% of storage and throughput will be diesel, where the high boiling point of diesel fuel used in vehicles in Australia (a necessary step in its refining) largely eliminates the presence of benzene in that type of fuel.



What is Benzene?

Benzene is a common chemical that is a colorless or light yellow liquid at room temperature. It has a sweet odour and is highly flammable. It is formed from both natural processes and human activities.

The United States (US) Centre for Disease Control and Prevention (CDC) has determined that long-term exposure to high levels of benzene in the air can cause leukemia. While it is correct to say that there is no recognised 'safe' exposure level to benzene, this commentary needs to be put into perspective, as everyone is exposed to benzene on a daily basis.

There are recognised and accepted guidelines for ambient exposure to benzene and these have been utilised in this report. For example, the exposure guideline for 1-hour benzene concentrations at the nearest receptor is $580 \mu\text{g}/\text{m}^3$, whilst the modelled exposure value from this Assessment, using those conservatisms listed above, is only $8.93 \mu\text{g}/\text{m}^3$. The compliance factor percentage (CF%) is subsequently 1.54 %. As a result, the likelihood of unacceptable benzene exposure at the closest receptor is considered negligible and should not be of concern from a risk perspective.

Benzene relative Risk of Exposure

It is likely that a person would be exposed to much greater benzene levels travelling on the Kwinana freeway or walking along St. Georges Terrace during peak hour.

Everyone is exposed to natural sources of benzene whenever there are bush fires within the region.

Benzene is widely used across the world, and it ranks in the top 20 chemicals for production volume worldwide.

Some industries use benzene to make other chemicals that are used to make plastics, resins, nylon and synthetic fibers. Benzene is also used to make some types of lubricants, rubbers, dyes, detergents, drugs, and pesticides.

Studies have found that Indoor air within childcare and educational settings generally contain levels of benzene higher than those in outdoor air. Benzene in indoor air within those settings comes from products that contain benzene such as glues, paints, furniture wax, detergents, pesticides, carpets, soft and hard plastic toys, especially when exposed to heat or sunlight. [reference: *A Review on the Exposure to Benzene among Children in Schools, Preschools and Daycare Centres* (2019)]
<https://link.springer.com/article/10.5572/ajae.2019.13.3.151#:~:text=Benzene%2C%20has%20been%20measured%20in,exposed%20to%20indoor%20air%20pollutants.>

As noted above, benzene is a key component of a large range of plastics, including those used for toys. There is no regulated standard in Australia for the maximum level of benzene in children's toys, however; the European Union (EU) has a chemical safety requirement (2009/48/EC, ENEX11, ITEM III Chemical Properties) that "*all toys shall be designed and manufactured in such a way that they present no risk of adverse health effects due to exposure to chemical substances/mixtures in toys during foreseeable use*".

The directive is not restricted to toys but includes all products that can be used in a school or childcare setting and includes; paints, crayons, texters, pencils, plastic toys, teething aids, balloons, tents and play equipment, cosmetics, soap, and hand sanitizer.

The Benzene Directive [[82/806/EEC](#)] bans the use of benzene in toys placed on the market when the concentration of free form benzene exceeds 5 mg/kg or 5,000 parts per billion (ppb) of the weight of the toy or of part of the toy. To put this into perspective, a small ambient air BTEX sampling program undertaken by EAQ for the adjacent service station returned results below the level of reporting. Even if this was rounded up to the nearest whole number (being 2 ppb) it is still extremely below the EU toy chemical safety requirements.

Further, homes with attached garages (which include almost all homes within the locality) are expected to have mean benzene concentrations in indoor air which exceed the ambient air quality standards.

"In the homes where a car was regularly parked in the garage, 18-month average benzene concentrations of up to 101.3 micrograms m⁻³ were measured in the garage. Mean benzene values in all cars and most of the garages studied exceeded the benzene standard. In the study, the mean benzene concentration in the room above the garage in a home was nearly 2.5 times the ambient air standard".

<https://pubmed.ncbi.nlm.nih.gov/11329696/#:~:text=The%20study%20demonstrates%20that%20there,to%20reduce%20risks%20to%20health>

What is Vapor Recovery?

Vapour recovery control equipment aims to capture petrol vapours before they enter the atmosphere. They are designed in two stages – VR1 and VR2.

VR1 captures displaced vapours from storage tanks when a tanker delivers petrol to a service station, while VR2 captures vapours at the bowser while a motorist refuels.

In order to be certified, a VR1 system must collect at least 95% of displaced vapours for return to the delivery truck while a VR2 system must collect at least 95% of the vapours resulting from refuelling vehicles.

The use of VR1 technology has been required in some Australian jurisdictions since the mid 1980. It has been a requirement to install VR1 systems at all petrol stations throughout Western Australia since 1998

The use of both VR1 and VR2 technology is considered safe and industry best practice.

VR2 was developed in California in the 1980's and legislated as a requirement for all high flow stations within that jurisdiction by 1991. While there were publicised teething problems identified with vapor return line blockages, these initial design issues have been mitigated over time, with automated monitoring and regular servicing schedules now a standard part of the system.

The use of VR2 It is not mandated in any Australian jurisdiction, except for NSW, which has required VR1 and VR2 to be implemented for new stations within the Sydney metropolitan area since 2009 and the greater Sydney area (Wollongong – Blue Mountains – Newcastle regions) since 2017.

VR1 and VR2 is proposed as part of this development.

Assessment Outcomes

The outcomes of the Assessment found that the primary pollutants of Benzene, Toluene, Ethyl benzene, Xylenes, Cyclohexane, *n*-Hexane and Styrene were predicted to have ground level concentrations lower than acceptable exposure limits set by the National Environment Protection (Air Toxics) Measure and other relevant jurisdictional recommendations when utilising both Vapour Recovery Phase 1 (required) and Vapour Recovery Phase 2 (proposed).

The predicted ground level concentrations of these primary pollutants, utilising Vapour Recovery Phase 1 & 2 technologies, demonstrated that the proposed Fuel Service Station emissions will not have an unreasonable impact on the health of existing sensitive receptors or sensitive land uses, and moreover; the cumulative emissions from the proposed activity and that of the approved adjacent service station are predicted to be below the exposure criteria at key sensitive receptor locations, to include the adjacent child care facilities between their respective child care operational hours.

Finally, the small ambient air BTEX sampling program showed that when using the largest quantifiable value from the BTEX sampling program for benzene (2 ppbV), and then scaling up the measured ambient concentration of benzene to represent that winds were blowing toward the monitor all of the time (x 10), the final ambient value for benzene measured at the monitors was approximately 20 ppbV. Converting ppb to the exposure limit units of $\mu\text{g}/\text{m}^3$, the approximate value of ambient benzene was $64 \mu\text{g}/\text{m}^3$.

This $64 \mu\text{g}/\text{m}^3$ is only 11 % of the accepted exposure limit standard of $580 \mu\text{g}/\text{m}^3$, and therefore likelihood of benzene concentrations approaching the ambient exposure criterion (human health) at the childcare centres due to emissions from the proposed Fuel Service Station is negligible.

1 Background & Scope

Environmental & Air Quality Consulting Pty Ltd (EAQ) was engaged by Golden Bay Neighbourhood Centre (the Proponent) to undertake an Air Emissions’ Impact Assessment (the Assessment) of a proposed 24-hour Fuel Service Station (the Site) to be located at Lot 622, (2) Aurea Boulevard, Golden Bay Western Australia.

The Assessment addressed toxic emissions of principal chemical compounds in petrols by undertaking a site-specific scientific Assessment into the short and long-term health risks associated with vapour emissions from the Site.

The Assessment accounted for cumulative emissions’ impacts by including those emissions’ contributions from an adjacent service station (the Adjacent site) that resides opposite the Site along Aurea Boulevard.

Vapour emission rates assessed were developed from:

- NPI Emission Estimation Technique Manual ([NPI, 1999](#)) for Aggregated Emissions from Service Stations (Environment Australia);
- Air Toxics “Hot Spots” Program: Gasoline Service Stations Industry wide Assessment Guidelines – Toxics Committee of the California Air Pollution Control Officers Association ([CAPCOA, 1997](#)); and
- Brisbane City Council methodology for service stations (BCC, 2017).

The BCC, 2017 methodology was utilised to derive hourly throughput rates for service stations based on normal and peak traffic flows. This method is widely accepted as the input “parameter” for traffic flows in urban areas.

1.1 Assessment Scope

The Assessment was undertaken to determine the extent of offsite pollutant impacts beyond the boundary of the Site, and in accounting for cumulative emissions from the Adjacent site, and subsequently determining the risk of health and amenity impacts for existing and future sensitive receivers and/or sensitive land uses (receptors).

The Assessment predicted ground level concentrations (GLCs) of primary pollutants from vapour losses using regulatory standard dispersion modelling techniques.

Importantly, the Adjacent site has been previously assessed by another consultant (LWC) ^[1] and those assumptions and emissions’ sources presented by LWC have been adopted herein to represent the Adjacent site.

The predicted GLCs were compared to the regulatory criteria for each pollutant assessed to determine if those GLCs would cause a health or amenity impact at the nearest receptor.

The model of choice was Aermოდ and its supporting pre- and post- processors.

¹ Land and Water Consulting (LWC) Emissions Impact Assessment, Proposed Service Station, Aurea Boulevard, Golden Bay, Western Australia: July 2021



1.1.1 Legislative Context

The Western Australia (WA) Environmental Protection Authority (EPA) 2005 Guidance for the Assessment of Environmental Factors document, *Separation Distances between Industrial and Sensitive Land Uses* recommends a buffer separation distance for Service Stations / Convenience Store Fuel Facilities and the nearest sensitive receptor as follows:

Table 1-1: WA EPA Guidance for Separation Distances

50 m	Operating during normal business hours of Monday – Saturday from 0700 – 1900 hours
100 m	Freeway service stations
200 m	Service stations in operations for 24 hours daily

Buffer separation distances are recommended in the absence of any site-specific technical assessments. The proposed Site activity is not a Prescribed Premise with regard to the WA Department of Water and Environmental Regulation (DWER).

On this basis the EPA recommended buffer of 200 metres (m) implies that where the separation distance is not met, a further assessment of applicable emissions should be undertaken to support the application and thus inform the risk of health and amenity impacts at the nearest receptor.

“Sensitive land uses include residential development, hospitals, hotels, motels, hostels, caravan parks, schools, nursing homes, child care facilities, shopping centres, playgrounds and some public buildings. Some commercial, institutional and industrial land uses which require high levels of amenity or are sensitive to particular emissions may also be considered “sensitive land uses”. Examples include some retail outlets, offices and training centres, and some types of storage and manufacturing.”

The emission sources at the Site comprise the ventilation of the sub-terrain fuel storage tanks, and the refuelling bowsers (4 bowsers, i.e., 8 dispensers). Incidental spills can also be a source of vapour release, albeit minor. Emission sources are primarily passive vapour losses from refilling (storage tanks) and bower refuelling processes.

1.1.2 Assessment Substances

Principal chemical compounds (pollutants) typically emitted from service station activities are listed below. These compounds are part of the Total Volatile Organic Compounds (VOCs) emitted, which are assessed in the first instance, and those individual pollutant contributions are then derived based on the percentage contribution of those pollutants within the Total VOC emissions.

Table 1-2: Assessment Substances (pollutants)

Pollutants			
Benzene	Cyclohexane	Ethyl benzene	Styrene
Toluene	n-Hexane	Xylenes	





1.2 Guidance for Assessing Impacts

The National Environment Protection (Air Toxics) Measure (NEPM) prescribes ambient air emission limits for a range of air toxics’ pollutants. These limits, together with other jurisdictional recommendations and those of the WA DWER have been adopted for this Assessment, with the VIC EPA 2002 1-hr benzene exposure value also adopted for short-term exposure of benzene.

These receptor exposure limits are listed in **Table 1-3** to follow.

Table 1-3: Assessment Criteria for Toxic Substances

Substance	Averaging Period	Criteria Source	Maximum (ambient) concentration	
			ppm	µg/m ³ at 25 ⁰ C
Benzene	1 hour	VIC EPA 2022	0.18	580
		EPA NSW 2016	0.009	29
Toluene	Annual		0.003	9.6
	24 hour	NEPM 2011	1	3,770
Ethyl benzene	Annual		0.1	377
	1 hour	EPA NSW 2016	1.8	8,000
Xylenes	Annual	Toxicos 2011		270
	24 hour	NEPM 2011	0.25	1,080
Cyclohexane <i>n</i> -Hexane	Annual		0.2	870
	1 hour	EPA NSW 2016	5	190
Styrene	1 hour	Dept. of Health WA	0.9	3,200
			70	64

1.3 The Site

The Assessment Site is located at Lot 622, (2) Aurea Boulevard, Golden Bay Western Australia.

It is part of a commercial site that comprises this service station Site, fast food outlet(s), liquor store, specialty shop(s) and supermarket, and multiple parking bays.

The Site is proposed to be located on the corner of Aurea Boulevard and Thundelarra Drive. This corner is part of a “roundabout” intersection with commercial sites on all four exit corners of the roundabout.

Directly to the south-east and approximately 70 m from the Site is an existing Adjacent service station site which is currently under construction.

The proposed Site is directly east of, and north-east of existing commercial sites to include a childcare Facility. There is also an additional childcare Facility to the south-west of the proposed Site, and directly west of the Adjacent service station site.

Importantly, both childcare Facility’s have 5-day week operational hours between the maximal hours of 6AM-7PM inclusive. The childcare Facilities are not exposed to airborne emissions continuously given that childcare staff and children do not inhabit these properties outside of operational childcare hours.

The nearest existing and future urban dwellings (house), from the Site’s central refuelling bowser location, are approximately 100 m to the north, 75 m south-west, 90 m west and 130 m south of the proposed Site.

The proposed Site will comprise the following main features:

- 4 bowser ranks comprising a total of 8 bowser outlets at any one time;
- 8 x refuelling bays, 6 parking bays and 2 x disabled parking bays & general convenience store;
- The types of fuels proposed are;
 - Diesel (40 kL),
 - ULP 91 (80 kL),
 - ULP 95 (30 kL),
 - ULP 98 (30 kL),
- Bulk refuelling events will take place up to three times weekly, or every 3 days annually averaged;
 - Tanker delivery of up to 1,000 Litres per minute (60,000 Litres per hour).
- Average refuelling volume daily 26,610 Litres; and
- The peak flow of vehicles per hour is anticipated at 40-50.

The Locality of the Site and assessed sensitive receptors, the Site design and Model depiction are illustrated in the following **Figures**.

Figure 3-1 illustrates the two service stations and the adjacent childcare Facilities. The “red” crosses are those discrete receptor locations used to assess impacts at each of the childcare Facilities.



LOCALITY: Golden Bay (Western Australia)
 53 kilometres south, south-west of Perth

Ladybug Twenty Pty Ltd
 Proposed 24-Hr Service Station
EMISSIONS IMPACT ASSESSMENT



LEGEND

- Locality
- Site Boundary
- Nearest Urban Houses
- Child Care Facilities
- Adjacent site
- Local Road Network

Prepared By:
 J. Hurley
 Reviewed By:
 DSB
 Released:
 14.03.2023



Figure 1-1: Proposed 24-hr Golden Bay Service Station (assessed)

C plan

Built Form
& Scale



Figure 1-2: Lot 622 (2) Aurea Boulevard, Golden Bay Western Australia

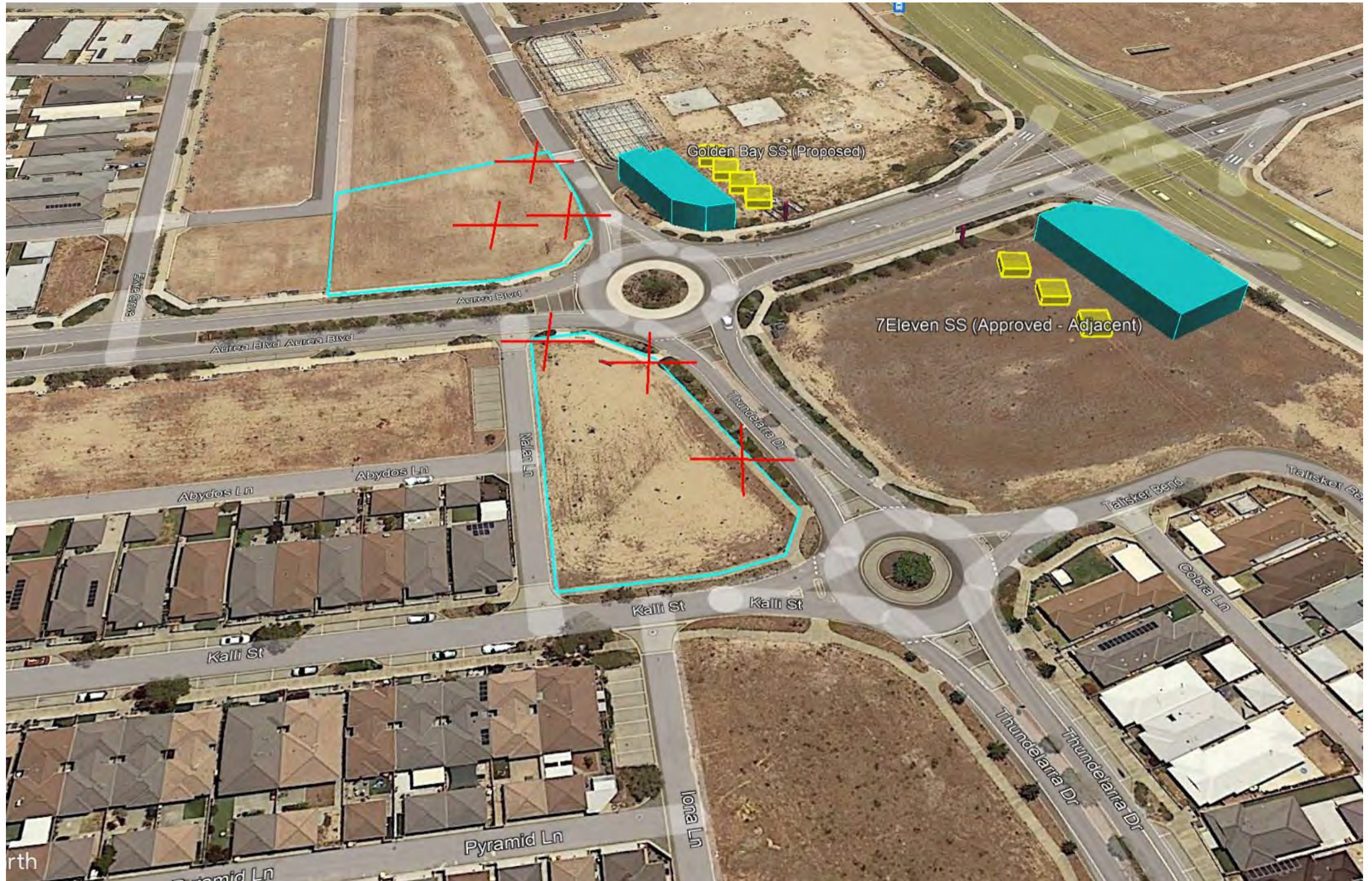

Figure 1-3: Modelling Depiction of Site Layout (Proposed) and Adjacent site (Approved)

2 Emission Estimation

Activities at the Site that will produce emissions are related to losses of fuels through vapourisation or spillage and subsequent vapourisation of the spill(s). These specific activities comprise:

- Submerged filling of underground storage tanks;
- Underground tank breathing losses;
- Vehicle refuelling;
- “Whoosh” emissions from removal of vehicle fuel cap; and
- Fuel spills, typically at the bowser.

The proposed Site throughputs are estimated based on the technology providers’ typical infrastructure design and average throughputs from similar Western Australian service stations. Precise hourly throughputs are however unknown at this stage, although there is negligible variability in refuelling characteristics for metropolitan service stations based on comparable populations.

There is a dearth of information within other Australian jurisdictions for estimating hourly throughputs based on typical traffic flows at metropolitan service stations, as a result the widely referenced 2017 Brisbane City Council (BCC) methodology for service stations has been used to estimate hourly emissions at the Site.

Emission estimates based on specific emission compounds (**refer Table 1-2**) were derived using the NPI, 1999 and CAPCOA, 1997 guidelines for emission estimation factors.

Vapour recovery (VR) at the Site will be in place for submerged underground storage tank(s) referred to as VR1 and at the bowser refuelling points i.e., VR2.

2.1 Bulk Deliveries and Emissions

The maximum volume of fuel that can be dispensed into the storage tanks at the Site is approximately 60,000 L/hour. The estimated total daily sale of fuels is 25,610 Litres. The Site will receive, on average, approximately 3 bulk deliveries of fuels per 7 days, between the daily hours of 0700 hrs – 2200hrs.

Although there are approx., 3 deliveries per week of 60,000 L or less, the schedule will shift based on fuel volumes dispensed. To account for variability in daily hours where deliveries are made; the delivery of bulk fuels is modelled 1-hourly, for each day and successive hour during those delivery times.

Table 2-1 lists an example of the delivery schedule and subsequent hourly emissions trend for bulk fuel deliveries.



Table 2-1: Example of Bulk Fuel Delivery Schedule (L/hr)

Time (24 hrs)	Monday	Tuesday	Wednesday	Thursday	Friday	Saturday	Sunday
0700	60,000						
0800		60,000					
0900			60,000				
1000				60,000			
1100					60,000		
1200						60,000	
1300							60,000
1400	60,000						
1500		60,000					
1600			60,000				
1700				60,000			
1800					60,000		
1900						60,000	
2000							60,000
2100	60,000						
2200		60,000					

2.2 VOC Emissions

Of the fuel types proposed, ULP emissions represent approximately 78% of total fuel storage with diesel representing approximately 22%. ULP contains the higher volatile fraction compared to diesel, as such all emissions in this Assessment have been assumed as ULP. This approach is conservative. There are no proposed Ethanol blend fuels e.g., E5, E10. The vapour composition of VOCs in petroleum fuel (NPI, 1999), are listed in Table 2-2.

The composition of Benzene in fuel will be lower than the NPI, 1999 value of 2.9% weight, because the percentage of Benzene in fuel is now limited to a maximum of 1% by the Fuel Standard (Petrol Determination) 2001. The NPI, 1999 figure is therefore conservative.

Table 2-2: Composition of Petrol (NPI, 1999)

Species	Petrol Liquid (% weight)	Petrol Vapour (% weight)
Benzene	2.9	0.950
Cyclohexane	0.2	0.06370
Ethylbenzene	2.0	0.07910
n-Hexane	3.5	1.730
Styrene	0.1	0.00282
Toluene	10.4	1.080
Xylenes	12.2	0.433

The composition percentages of the compounds listed above were applied to the modelling outcomes of the final time-averaged emission rate GLC estimates (vapour and spill vapour losses) to derive individual pollutant contributions to airborne vapour impacts at the nearest receptor.



2.3 Site Operational Data

Table 2-3: Proposed Site Operating Detail

Parameter	Operational Data
Operating hours	24 hours / 7 days per week
Tanker delivery	Maximum 60,000 L/hour
Average Daily Refuelling Volume	25,610 L
Vent stack	4.5 m high
Filling Stations/Bowsers	4 x Bowsers / 8 x Grade filling points (located below full canopy)
Fuel Storage	Diesel 40 kL, ULP 91 80 kL, ULP 95 30 kL, ULP 30 kL.

2.4 Derived Emission Factors

Emissions generated from activities at the Site have been derived based on those vapour losses published by the NPI and CAPCOA guidance. **Table 2-4** lists those emission factors that apply to those processes where vapour losses occur. Those values bolded in **Red** were used in deriving the emissions for Assessment.

Table 2-4: Emissions Factors for Service Stations

Emission Source	NPI, 1999 Mg / L throughput	CAPCOA, 1997 Lbs / 1000 Gallons throughput
<i>Underground Tank Filling</i>	-	-
Submerged Filling	880	8.4
Splash Filling	1380	-
Submerged filling with vapour balance	40	0.42
Underground tank breathing losses	120	0.84
<i>Vehicle Refuelling</i>	-	-
Displacement Losses (uncontrolled)	1320	8.4
Displacement Losses (90% controlled i.e., VR 2)	132	0.74
<i>Spillages</i>	-	-
Uncontrolled	80	0.61
Controlled	-	0.41
<i>"Whoosh" Emissions (fuel cap removal)</i>	-	0.26 - 0.66

The refuelling activities are considered to be volume emission sources. These have been assessed utilising the CAPCOA, 1997 emission factors. Vent emissions from storage tank filling has been assessed using the NPI, 1999 emission factors.



2.4.1 Fuel Throughput Trends

There are two approaches to determining the hourly throughputs of fuel dispensing for service stations in accordance with the BCC, 2017 recommendations.

Method 1 considers known daily or weekly fuel dispensing trends where an estimate of hourly dispensing volumes (L) can be derived. Where the peak hourly dispensing volume is known, the daily hourly trends can then be derived using the BCC, 2017 published profiles as listed in Table 2-5.

Table 2-5: Representative Fuel Throughputs (BCC, 2017)

Hour	Hourly Profile (%)
1	1.20%
2	0.80%
3	0.60%
4	0.80%
5	1.90%
6	4.60%
7	5.50%
8	5.70%
9	5.50%
10	5.70%
11	6.00%
12	6.00%
13	5.70%
14	5.60%
15	5.90%
16	6.15%
17	6.15%
18	5.80%
19	5.10%
20	4.00%
21	3.50%
22	3.40%
23	2.60%
24	1.80%

If no fuel data is available for the proposal, then Method 2 is employed; where the number of bowsers and refuelling points are counted and assuming the average dispensing rate per vehicle of 35 L, with each vehicle taking approximately 5 minutes to refuel, the hourly profile in Table 2-5 is applied to the peak amount of fuel dispensed over 24 hours to derive those other hourly volumes. In Table 2-5 the peak throughput hours are 4-5pm.

Method 1 was employed for this Assessment and utilising the operational detail in Table 2-3.

Applying the Average Daily Refuelling Volume of 25,610 L, the emission factors in Table 2-4, and deriving the hourly profiles based on Table 2-5, the hourly Total VOC mass emission rates in grams per second



(g/s) are developed. These mass emission rates represent the combined (ALL) number of filling points (8) at any one time, and single bowser (SINGLE) operations, and are listed in Table 2-6.

Table 2-6: Factored Total VOC Emission Rates per Hour (VR1 + VR2)

Hour	Throughput % daily volume/hr	Petrol Throughput (L/hr)	% to Peak Daily Hour	ALL Bowsers Mass Emission Rate (g/s)	SINGLE Bowser Mass Emission Rate (g/s)
1	1.20%	307	19.51%	0.198	0.050
2	0.80%	205	13.01%	0.132	0.033
3	0.60%	154	9.76%	0.099	0.025
4	0.80%	205	13.01%	0.132	0.033
5	1.90%	487	30.89%	0.314	0.078
6	4.60%	1,178	74.80%	0.759	0.190
7	5.50%	1,409	89.43%	0.908	0.227
8	5.70%	1,460	92.68%	0.941	0.235
9	5.50%	1,409	89.43%	0.908	0.227
10	5.70%	1,460	92.68%	0.941	0.235
11	6.00%	1,537	97.56%	0.990	0.248
12	6.00%	1,537	97.56%	0.990	0.248
13	5.70%	1,460	92.68%	0.941	0.235
14	5.60%	1,434	91.06%	0.924	0.231
15	5.90%	1,511	95.93%	0.974	0.243
16	6.15%	1,575	100.00%	1.015	0.254
17	6.15%	1,575	100.00%	1.015	0.254
18	5.80%	1,485	94.31%	0.957	0.239
19	5.10%	1,306	82.93%	0.842	0.210
20	4.00%	1,024	65.04%	0.660	0.165
21	3.50%	896	56.91%	0.578	0.144
22	3.40%	871	55.28%	0.561	0.140
23	2.60%	666	42.28%	0.429	0.107
24	1.80%	461	29.27%	0.297	0.074

Table 2-7 lists the summarised maximum emission rates for the proposed Site adopting VR1 and VR2 emissions controls.

Table 2-7: Summary of Proposed Site’s Fuel Service Station Emissions

Emission Source	Emission Type	Peak VOC Mass Emission Rate (g/s)	Stack Diameter (m)	Emission Velocity (m/s)
Storage Tanker Vent Stack	Bulk Filling (Vapour Balance and Breathing Losses) – VR1	0.267	0.1	0.1



Passive Emissions from Vehicle Refuelling (VR 1 & 2)	Refuelling Losses (Controlled), Spillages (controlled/uncontrolled), and maximum "Whoosh" Emissions	1.015 (all 8 filling points)	-	-
--	---	------------------------------	---	---

Appendix A presents the summary calculations for the derived mass emission rates.

2.4.2 Cumulative Emissions Impacts

To adequately assess the Adjacent service station site together with the proposed Site, EAQ has adopted the reported operational data in the LWC report (footnote 1) as listed in Table 2-8.

Table 2-8: Adjacent service station site's operational data

Parameter	Operational Data
Operating hours	24 hours / 7 days per week
Tanker delivery	Maximum 40,000 L/hour
Average Daily Refuelling Volume	13,800 L
Vent stack	4.0 m high @ 75mm diameter
Filling Stations/Bowsers	3 x Bowsers / 6 x Grade filling points
Fuel Storage	Diesel 50 kL, ULP 130 kL.

Table 2-9 lists the summarised maximum emission rates, derived as described above, for the Adjacent service station site adopting VR1 and VR2 emissions controls.

Table 2-9: Summary of Adjacent site's Fuel Service Station Emissions

Emission Source	Emission Type	Peak VOC Mass Emission Rate (g/s)	Stack Diameter (m)	Emission Velocity (m/s)
Storage Tanker Vent Stack	Bulk Filling (Vapour Balance and Breathing Losses) – VR1	0.178	0.075	0.1
Passive Emissions from Vehicle Refuelling (VR 1 & 2)	Refuelling Losses (Controlled), Spillages (controlled/uncontrolled), and maximum "Whoosh" Emissions	0.410 (all 6 filling points)	-	-

3 Aermod Dispersion Modelling Methods

3.1 Meteorology

A 2-year annual dataset (April-2020-to-April-2022) of meteorology was developed using surface observations from the Mandurah Bureau of Meteorology (BoM) Automatic Weather Station (AWS) and CSIRO's TAPM prognostic model for upper air characteristics. The Mandurah BoM AWS is approximately 12 kms south, south-west of the Site and representative of the assessment domain given the Site's and AWS's proximity to the coastline and separated by approximately 0.05 decimal degrees of latitude (approx., 4 kms).

3.2 Sensitive Receptors

Discrete sensitive receptors representing commercial, residential, and childcare Facilities were placed at locations closest and surrounding the Site (refer **Figure 1-1**). These receptors were analysed for their ground level impact concentrations of vapour emissions and compared against regulatory guidelines.

3.3 Building Profile Input Program (BPIP)

Building wake effects occur for those vertical stack emissions, in this case passive ventilation of the storage tank vent. An example of the Aermod Input File is presented in [Appendix B](#).

3.4 Dispersion Modelling Limitations

By definition, air quality models can only approximate atmospheric processes. Many assumptions and simplifications are required to describe real phenomena in mathematical equations. Model uncertainties can result from:

- Simplifications and accuracy limitations related to source data;
- Extrapolation of meteorological data from selected locations to a larger region; and
- Simplifications to model physics to replicate the random nature of atmospheric dispersion processes.

Models are reasonable and reliable in estimating the maximum concentrations occurring on an average basis. That is, the maximum concentration that may occur at a given time somewhere within the model domain, as opposed to the exact concentration at a point at a given time will usually be within the $\pm 10\%$ to $\pm 40\%$ range (US EPA, 2003).

Typically, a model is viewed as replicating dispersion processes if it can predict within a factor of two, and if it can replicate the temporal and meteorological variations associated with monitoring data. Model predictions at a specific site and for a specific hour, however, may correlate poorly with the associated observations due to the above-indicated uncertainties. For example, an uncertainty of 5° to 10° in the measured wind direction can result in concentration errors of 20% to 70% for an individual event (US EPA, 2003).

4 Assessment Results & Discussion

The Assessment of the Proposed Aurea Boulevard Fuel Service Station, and accounting for cumulative emissions' impacts from the Adjacent service station site, has projected ground level concentrations (GLCs) at the nearest sensitive receptors (refer **Figures 1-1** and **1-3**) for assessed pollutants of BTEX (Benzene, Toluene, Ethyl benzene, Xylenes), Cyclohexane, *n*-Hexane and Styrene that are below the guideline exposure standards when employing both VR1 and VR2.

These pollutants were assessed by firstly modelling Total VOCs as a function of emission factors for fuel storage and vehicle dispensing volumes according to those methods in [Section 2](#).

Those Total VOC GLCs projected were then revised to determine the percentage mass emission rate contributions for these pollutants (**refer Table 2-2**).

Table 4-1 list each predicted pollutant concentration for each averaging period at those assessed sensitive receptors. These pollutant concentrations are revised based on each compounds vapour contribution to petrol VOC emissions. Additionally, these predicted pollutant concentrations reflect both VR1 and VR2 vapour recovery.

Within **Table 4-1** is each pollutants respective assessment criteria, the projected GLCs from the modelling Assessment and the revised projected GLCs at the nearest sensitive receptor (refer **Figures 1-1** and **1-3**) with a Percentage of Exposure Limit Value (%). This value represents the percentage ratio of projected GLCs compared to the assessment criteria for each pollutant.

A % < 100 % shows that the projected concentration at the sensitive receptor location achieves less than the assessment criteria i.e PASS, whereas % ≥ 100 % shows non-compliance against the assessment criteria i.e., FAIL.

The magnitude of the compliance PASS/FAIL can be readily gauged by the size of the Percentage of Exposure Limit Value (%).

- All GLC values reported for each sensitive receptor are the maximum, Rank 1 values for all averaging periods; and
- All units of concentration are in $\mu\text{g}/\text{m}^3$ unless stated otherwise.

In reviewing the predicted GLCs for those pollutants in **Table 4-1**, within this Assessment, the pollutant emissions at the nearest sensitive receptors are less than the exposure limits in ambient air when employing VR1 and VR2 vapour recovery.

Based on the predicted ground level concentrations using VR1 and VR2, vapours from the Site, and cumulative vapours from the Site and Adjacent site, will not negatively impact the health of the nearest sensitive receptor or sensitive land use within the Locality.



Table 4-1: Proposed Site - Assessment Results for GLC's of Pollutants (VR1 & VR2) @ Nearest Urban Dwellings

Receptor Location	Pollutant	Averaging Period	Exposure Limit $\mu\text{g}/\text{m}^3$ at 25°C	Predicted GLC ($\mu\text{g}/\text{m}^3$)	% of CF	Pass/Fail	Averaging Period	Exposure Limit $\mu\text{g}/\text{m}^3$ at 25°C	Predicted GLC ($\mu\text{g}/\text{m}^3$)	% of CF	Pass/Fail															
North	Benzene	1-hour	580	7.69	1.33%	Pass	Annual	9.6	0.17	1.79%	Pass															
West				8.27	1.43%	Pass			0.15	1.58%	Pass															
SW				8.94	1.54%	Pass			0.21	2.22%	Pass															
SSE				4.84	0.84%	Pass			0.10	1.03%	Pass															
North	Toluene	24-hour	3,770	0.84	0.02%	Pass	Annual	377	0.20	0.05%	Pass															
West				0.83	0.02%	Pass			0.17	0.05%	Pass															
SW				1.01	0.03%	Pass			0.24	0.06%	Pass															
SSE				0.68	0.02%	Pass			0.11	0.03%	Pass															
North	Ethyl benzene	1-hour	8,000	0.64	0.01%	Pass	Annual	270	0.01	0.01%	Pass															
West				0.69	0.01%	Pass			0.01	0.00%	Pass															
SW				0.74	0.01%	Pass			0.02	0.01%	Pass															
SSE				0.40	0.01%	Pass			0.01	0.00%	Pass															
North	Xylenes	24-hour	1,080	0.34	0.03%	Pass	Annual	870	0.08	0.01%	Pass															
West				0.33	0.03%	Pass			0.07	0.01%	Pass															
SW				0.40	0.04%	Pass			0.10	0.01%	Pass															
SSE				0.27	0.03%	Pass			0.05	0.01%	Pass															
North	Cyclohexane	1-hour	190	0.52	0.27%	Pass																				
West				0.55	0.29%	Pass																				
SW				0.60	0.32%	Pass																				
SSE				0.32	0.17%	Pass																				
North	n-Hexane	1-hour	3,200	14.00	0.44%	Pass																				
West				15.07	0.47%	Pass																				
SW				16.27	0.51%	Pass																				
SSE				8.82	0.28%	Pass																				
North	Styrene	1-hour	64	0.02	0.04%	Pass																				
West				0.02	0.04%	Pass																				
SW				0.03	0.04%	Pass																				
SSE				0.01	0.02%	Pass																				



Table 4-2: Proposed Site & Adjacent site – CUMULATIVE Assessment Results for GLC’s of Pollutants (VR1 & VR2) @ Nearest Urban Dwellings

Receptor Location	Pollutant	Averaging Period	Exposure Limit $\mu\text{g}/\text{m}^3$ at 25°C	Predicted GLC ($\mu\text{g}/\text{m}^3$)	% of CF	Pass/Fail	Averaging Period	Exposure Limit $\mu\text{g}/\text{m}^3$ at 25°C	Predicted GLC ($\mu\text{g}/\text{m}^3$)	% of CF	Pass/Fail
North	Benzene	1-hour	580	8.86	1.53%	Pass	Annual	9.6	0.19	2.02%	Pass
West				12.87	2.22%	Pass			0.18	1.83%	Pass
SW				10.98	1.89%	Pass			0.26	2.67%	Pass
SSE				9.43	1.63%	Pass			0.22	2.28%	Pass
North	Toluene	24-hour	3,770	0.95	0.03%	Pass	Annual	377	0.22	0.06%	Pass
West				1.12	0.03%	Pass			0.20	0.05%	Pass
SW				1.22	0.03%	Pass			0.29	0.08%	Pass
SSE				1.25	0.03%	Pass			0.25	0.07%	Pass
North	Ethyl benzene	1-hour	8,000	0.74	0.01%	Pass	Annual	270	0.02	0.01%	Pass
West				1.07	0.01%	Pass			0.01	0.01%	Pass
SW				0.91	0.01%	Pass			0.02	0.01%	Pass
SSE				0.79	0.01%	Pass			0.02	0.01%	Pass
North	Xylenes	24-hour	1,080	0.38	0.04%	Pass	Annual	870	0.09	0.01%	Pass
West				0.45	0.04%	Pass			0.08	0.01%	Pass
SW				0.49	0.05%	Pass			0.12	0.01%	Pass
SSE				0.50	0.05%	Pass			0.10	0.01%	Pass
North	Cyclohexane	1-hour	190	0.59	0.31%	Pass					
West				0.86	0.45%	Pass					
SW				0.74	0.39%	Pass					
North	n-Hexane	1-hour	3,200	16.14	0.50%	Pass					
West				23.43	0.73%	Pass					
SW				19.99	0.62%	Pass					
North	Styrene	1-hour	64	0.03	0.04%	Pass					
West				0.04	0.06%	Pass					
SW				0.03	0.05%	Pass					
SSE				0.03	0.04%	Pass					

Table 4-3: Proposed Site & Adjacent site – CUMULATIVE Assessment Results for GLC’s of Pollutants (VR1 & VR2) @ Childcare Facilities

Receptor Location	Pollutant	Averaging Period	Exposure Limit $\mu\text{g}/\text{m}^3$ at 25°C	Predicted GLC ($\mu\text{g}/\text{m}^3$)	% of CF	Pass/Fail	Averaging Period	Exposure Limit $\mu\text{g}/\text{m}^3$ at 25°C	Predicted GLC ($\mu\text{g}/\text{m}^3$)	% of CF	Pass/Fail
CC1	Benzene	1-hour	580	21.93	3.78%	Pass	Annual	9.6	0.40	4.16%	Pass
CC2				26.98	4.65%	Pass			0.58	6.03%	Pass
CC3				17.00	2.93%	Pass			0.30	3.07%	Pass
CC4				13.61	2.35%	Pass			0.20	2.12%	Pass
CC5				15.19	2.62%	Pass			0.23	2.44%	Pass
CC6				10.88	1.88%	Pass			0.15	1.56%	Pass
CC1	Toluene	24-hour	3,770	1.93	0.05%	Pass	Annual	377	0.45	0.12%	Pass
CC2				2.68	0.07%	Pass			0.66	0.17%	Pass
CC3				1.49	0.04%	Pass			0.34	0.09%	Pass
CC4				1.11	0.03%	Pass			0.23	0.06%	Pass
CC5				1.25	0.03%	Pass			0.27	0.07%	Pass
CC6				0.85	0.02%	Pass			0.17	0.05%	Pass
CC1	Ethyl benzene	1-hour	8,000	1.83	0.02%	Pass	Annual	270	0.03	0.01%	Pass
CC2				2.25	0.03%	Pass			0.05	0.02%	Pass
CC3				1.42	0.02%	Pass			0.02	0.01%	Pass
CC4				1.13	0.01%	Pass			0.02	0.01%	Pass
CC5				1.26	0.02%	Pass			0.02	0.01%	Pass
CC6				0.91	0.01%	Pass			0.01	0.00%	Pass
CC1	Xylenes	24-hour	1,080	0.77	0.07%	Pass	Annual	870	0.18	0.02%	Pass
CC2				1.08	0.10%	Pass			0.26	0.03%	Pass
CC3				0.60	0.06%	Pass			0.13	0.02%	Pass
CC4				0.44	0.04%	Pass			0.09	0.01%	Pass
CC5				0.50	0.05%	Pass			0.11	0.01%	Pass
CC6				0.34	0.03%	Pass			0.07	0.01%	Pass



Receptor Location	Pollutant	Averaging Period	Exposure Limit $\mu\text{g}/\text{m}^3$ at 25°C	Predicted GLC ($\mu\text{g}/\text{m}^3$)	% of CF	Pass/Fail
CC1	Cyclohexane	1-hour	190	1.47	0.77%	Pass
CC2				1.81	0.95%	Pass
CC3				1.14	0.60%	Pass
CC4				0.91	0.48%	Pass
CC5				1.02	0.54%	Pass
CC6				0.73	0.38%	Pass
CC1	n-Hexane	1-hour	3,200	39.94	1.25%	Pass
CC2				49.13	1.54%	Pass
CC3				30.95	0.97%	Pass
CC4				24.78	0.77%	Pass
CC5				27.66	0.86%	Pass
CC6				19.82	0.62%	Pass
CC1	Styrene	1-hour	64	0.07	0.10%	Pass
CC2				0.08	0.13%	Pass
CC3				0.05	0.08%	Pass
CC4				0.04	0.06%	Pass
CC5				0.05	0.07%	Pass
CC6				0.03	0.05%	Pass



5 Additional Information - Ambient BTEX Sampling

A small ambient air sampling program that targeted airborne BTEX chemistry from the adjacent existing service station was undertaken to determine if airborne benzene could be quantified in the locality.

The method included the deployment of SUMMA Cannisters, set for a 6-hour sampling ‘run’, that were located across the road from the existing service station approximately 40 metres from the nearest vehicle refuelling bowser.

40 metres was chosen to reflect the distance from the proposed Station to the adjacent existing childcare centre. In this way conclusions could be made as to whether BTEX emissions are likely to be quantified at the adjacent childcare centre and to what concentration. This information would provide greater insight into the risk of BTEX emissions having an adverse impact on the childcare centre and surrounding sensitive receptors.

To complement the SUMMA Cannisters, a Kestrel weather station was deployed adjacent to the SUMMA Cannisters location to record ground level wind speed, wind direction and temperature throughout the 6-hour sampling period. The aim was to target winds blowing from the existing service station in the direction of the SUMMA Cannisters.

The following Table lists the dates, times, BTEX concentrations measured and weather details for each sampling day.

Values for BTEX with a ‘<’ represent the limit of reporting (i.e., detection) for that sample/analyte. In other words, the result is not positive.

Table 5-1: BTEX Sampling Results

Sampling Date/Time ON	Average Wind Speed (m/s)	Average Wind Direction (degrees)	Average Wind Direction (Cardinal)	Average Temp. (°C)	Benzene ppb(V)	Ethylbenzene ppb(V)	Toluene ppb(V)	m- & p- Xylene ppb(V)	o- Xylene ppb(V)	Xylene ppb(V)
02/11/2023 @ 0540AM	1.45	125	SE	26.1	<1.5	<1.5	<1.5	<3.1	<1.5	<4.6
10/11/2023 @ 0520AM	1.37	158	SSE	19.2	<1.6	<1.6	<1.6	<3.2	<1.6	<4.8
11/11/2023 @ 0521AM	0.92	132	SE	20.8	<1.5	<1.5	2	<2.9	<1.5	<4.4
16/11/2023 @0522AM	0.93	88	E	21.6	<1.7	<1.7	<1.7	<3.4	<1.7	<5.0
19/11/2023 @ 0506AM	0.99	122	ESE	26.0	<1.4	<1.4	<1.4	<2.8	<1.4	<4.2

As was anticipated, it can be seen from **Table 5-1** that all ambient sampling results were below the limit of reporting for these BTEX analytes, with exception to Toluene on sampling day 3 (11.11.2023).

Although toluene was detected at extremely low concentration levels, BTEX vapours from the service station do not pose a high concentration risk to nearby receptors, in particular the childcare centre(s), due to (among others) daytime dispersive conditions, low volume passive emissions losses at the bowser resulting in low BTEX emissions, vapour recovery (VR1) at the bulk refuelling events, and length of dispersion pathway from emission source to receptor. Importantly, ambient pollutants from traffic vehicle emissions and other anthropological activities would always exist in ambient conditions.

Figure 5-1 below illustrates the wind direction and wind speed during SUMMA Cannister sampling. Although the winds fluctuate (as expected) the average wind vector (**Table 5-1**) is suited to the sampling design across the first three (3) sampling events. Importantly, the ambient concentration of BTEX attributed to vehicles and other anthropological sources would continue to exist under all weather conditions.

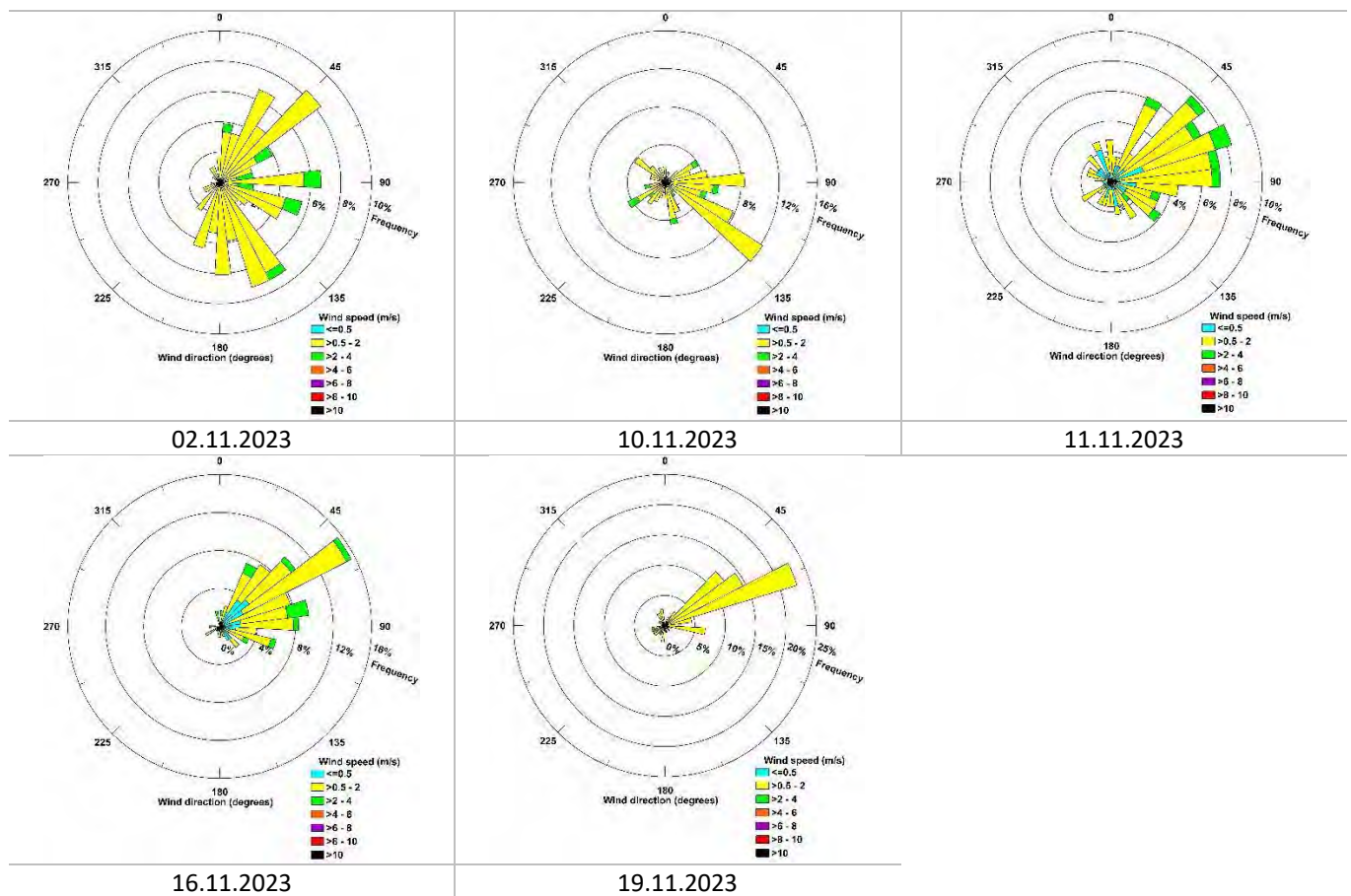

Figure 5-1: Wind Characteristics during SUMMA Cannister Sampling.

Referring to **Figure 5-1**, the average wind direction that was aimed for was from the southeast. Of the 3 sampling events where southeast winds prevailed, the percentage of the sampling period in which the winds were *actually* blowing from approx. 135° (+/-15°, or +/- 1 wind rose petal) were as follows:



- 02/11/2023 – 11%
- 10/11/2023 – 21%
- 11/11/2023 – 8%

As a result, these 3 sampling events are estimated to have been influenced by winds outside of the preferred southeast direction for approx., 90%, 80% and 90% of the total 6-hour sampling run.

If the benzene concentrations quantified in Table 5-1 were actual (i.e., above limit of detection), the largest quantified value for benzene would be 2 ppbV. Accounting for the winds prevailing from the southeast for approx., 10% of the sampling runs, the 2 ppbV can be multiplied by 10 to assume that winds were 100% of the time prevailing from the southeast. Converting ppbV to $\mu\text{g}/\text{m}^3$ at 25^oC, the derived ambient benzene concentrations are as follows:

Table 5-2: Derived Ambient Benzene Concentrations

Event	Benzene (ppbV)	Multiplied by 10	Benzene ($\mu\text{g}/\text{m}^3$)	Benzene 1-hr Criteria
2/11/2023	2	20	64	580
10/11/2023	2	20	64	580
11/11/2023	2	20	64	580

5.1 Ambient BTEX Sampling Conclusions

The ambient BTEX sampling program undertaken by EAQ was designed to capture winds from the SE to ensure capture of airborne BTEX in the direction of the proposed Station. In doing so this would allow a ‘transposition’ of the quantitative data collected to reflect the proposed Station and its potential risk of BTEX impacts on the adjacent childcare centre.

The SUMMA Cannister sampling data showed that BTEX vapours are negligible in ambient air within 40 metres downwind of the adjacent and existing service station. Where winds deviated from the preferred SE vector, the ambient concentrations of BTEX were still negligible. Under these conditions the emission vapours from vehicles and other anthropological contributions continue to emit a plethora of chemical vapours within the locality, although BTEX vapours were not readily detectable at 40 metres from the primary service station odour source.

Whilst the sampling program was small, the data supports that benzene in ambient air is at low concentrations. Moreover, when considering the VIC EPA 1-hr benzene exposure limit and subsequently derived low compliance factor percentages (CF%) for benzene at the nearest receptors, the risk of benzene exposure is negligible from a modern, best-practice service station which utilises VR1, and importantly VR2 vapour recovery technology.

The understanding of that risk informs stakeholders of “what is likely”, and in this case, the likelihood of BTEX chemistry exposure from the proposed Station is negligible at the nearest sensitive receptor.

DEVELOPMENT
ASSESSMENT PANEL

APPROVED

12-Mar-2024



Appendix A: Emissions Calculations

Bowser		Number of Dispensing Nozzles	8	hour	% daily volume/hr	Petrol Throughput (L/hr)	% to peak hr	L/hr	L/s	g/s	Final Value	Per Bowser	Emission Source	NPI 1999 mg/L throughput	CAPCOA Lbs/1000 Gallons throughput	CAPCOA mg/L throughput
VR2	Peak Hourly Volume at Bowsers (transactions [40-50/hr] x Litres per car)	1,575		1	1.20%	307	19.51%	307	0.085	0.198	0.198	0.050				
	CAPCOA (Lbs/1000gallons to mg/L)	2,320	mg/L	2	0.80%	205	13.01%	205	0.057	0.132	0.132	0.033	Underground Tank Filling			
	CAPCOA (Lbs/1000gallons to g/L)	2.320	g/L	3	0.60%	154	9.76%	154	0.043	0.099	0.099	0.025	Submerged Filling	880	8.4	1007
	Losses (g/L)	2.320	g/L/hr	4	0.80%	205	13.01%	205	0.057	0.132	0.132	0.033	Splash Filling	1380		
	VR 2 - 10% Losses (g/L)	2.320	g/L/hr	5	1.90%	487	30.89%	487	0.135	0.314	0.314	0.078	Submerged filling with vapour balance	40	0.42	50
	ESTIMATED TOTAL DAILY (24hr) VOLUME (L)	25,610		6	4.60%	1,178	74.80%	1,178	0.327	0.759	0.759	0.190	Underground tank breathing losses	120	0.84	101
				7	5.50%	1,409	89.43%	1,409	0.391	0.908	0.908	0.227	Vehicle Refuelling			
	E10 Volatilisation	1.5		8	5.70%	1,460	92.68%	1,460	0.405	0.941	0.941	0.235	Displacement Losses (uncontrolled)	1320	8.4	1007
	E10 % of T-Volumes	0%		9	5.50%	1,409	89.43%	1,409	0.391	0.908	0.908	0.227	Displacement Losses (90% controlled e.g VRU)	132	0.74	89
	E10 Fuel Ratio Factor	0		10	5.70%	1,460	92.68%	1,460	0.405	0.941	0.941	0.235	Spillages			
	% of Other Fuels	100%		11	6.00%	1,537	97.56%	1,537	0.427	0.990	0.990	0.248	Uncontrolled	80	0.61	73
	Fuel Ratio Factor	1.000		12	6.00%	1,537	97.56%	1,537	0.427	0.990	0.990	0.248	Controlled		0.41	49
				13	5.70%	1,460	92.68%	1,460	0.405	0.941	0.941	0.235	"Whoosh" Emissions		0.26 - 0.66	79
				14	5.60%	1,434	91.06%	1,434	0.398	0.924	0.924	0.231	"Whoosh" Emissions (averaged)		0.46	79
				15	5.90%	1,511	95.93%	1,511	0.420	0.974	0.974	0.243	Diesel	176		
			16	6.15%	1,575	100.00%	1,575	0.438	1.015	1.015	0.254	LPG	0.04			
			17	6.15%	1,575	100.00%	1,575	0.438	1.015	1.015	0.254					
			18	5.80%	1,485	94.31%	1,485	0.413	0.957	0.957	0.239					
			19	5.10%	1,306	82.93%	1,306	0.363	0.842	0.842	0.210					
			20	4.00%	1,024	65.04%	1,024	0.285	0.660	0.660	0.165					
			21	3.50%	896	56.91%	896	0.249	0.578	0.578	0.144					
			22	3.40%	871	55.28%	871	0.242	0.561	0.561	0.140					
			23	2.60%	666	42.28%	666	0.185	0.429	0.429	0.107					
			24	1.80%	461	29.27%	461	0.128	0.297	0.297	0.074					
				100.0%	25610							Max	1.015	0.254		
												SUM	16.5029	4.1257		
												Per Nozzle	2.0629	2.0629		
Storage Tanks		Time to Fill Tank	40 minutes													
VR 1	Total Volume/hr	60000	L/hr	14	5.60%	1,434	91.06%	1,434	0.398	0.924	0.924	0.231				
	NPI 1999	160	mg/L	15	5.90%	1,511	95.93%	1,511	0.420	0.974	0.974	0.243				
		9600000	mg/hr	16	6.15%	1,575	100.00%	1,575	0.438	1.015	1.015	0.254				
		9600.000	g/hr	17	6.15%	1,575	100.00%	1,575	0.438	1.015	1.015	0.254				
		2.667	g/s	18	5.80%	1,485	94.31%	1,485	0.413	0.957	0.957	0.239				
	4.5m High Vent Rate	0.00079	m3/s	19	5.10%	1,306	82.93%	1,306	0.363	0.842	0.842	0.210				
	VR1 10% losses	0.267	g/s	20	4.00%	1,024	65.04%	1,024	0.285	0.660	0.660	0.165				
	Final Value	0.267	g/s	21	3.50%	896	56.91%	896	0.249	0.578	0.578	0.144				
	Annually	8410666.667	grams	22	3.40%	871	55.28%	871	0.242	0.561	0.561	0.140				
		8410.666667	kgs	23	2.60%	666	42.28%	666	0.185	0.429	0.429	0.107				
		23.04292237	kgs/day	24	1.80%	461	29.27%	461	0.128	0.297	0.297	0.074				
	Deliveries weekly	2.869	kgs		100.0%	25610										
	Per delivery	0.960	kg/hr													
		0.267	g/s													
	Cars per hour	45														
L per car on average	35															
Peak Volumes Dispensed	1575															
Maximum Tanker Delivery (kL/hr)	60															
Types of Fuel	Diesel, ULT Diesel, 91, 95, 98															
Fuel Storage (kL)	Diesel	40														
	ULP 91	80														
	ULP 95	30														
	ULP 98	30														
Daily Sales	25610															
Annual Sales	9,347,561															
Tanker Volume	90000															
Deliveries per week	3.0															



Appendix B: Example of AERMOD Input File

74	BUILDHGT	STCK2	7.00	0.00	0.00	0.00	0.00	0.00
75	BUILDHGT	STCK2	0.00	0.00	0.00	0.00	0.00	0.00
76	BUILDHGT	STCK2	7.00	7.00	7.00	7.00	7.00	7.00
77	BUILDHGT	STCK2	7.00	0.00	0.00	0.00	0.00	0.00
78								
79	BUILDWID	VENT	0.00	0.00	0.00	0.00	0.00	31.87
80	BUILDWID	VENT	30.15	28.01	25.75	23.49	20.82	18.95
81	BUILDWID	VENT	16.51	0.00	0.00	0.00	0.00	0.00
82	BUILDWID	VENT	0.00	0.00	0.00	0.00	0.00	31.87
83	BUILDWID	VENT	30.15	28.01	25.75	23.49	20.82	18.95
84	BUILDWID	VENT	16.51	0.00	0.00	0.00	0.00	0.00
85								
86	BUILDWID	STCK2	0.00	0.00	0.00	0.00	0.00	0.00
87	BUILDWID	STCK2	0.00	0.00	0.00	0.00	0.00	0.00
88	BUILDWID	STCK2	29.12	0.00	0.00	0.00	0.00	0.00
89	BUILDWID	STCK2	0.00	0.00	0.00	0.00	0.00	0.00
90	BUILDWID	STCK2	44.01	43.53	41.72	38.65	35.78	32.95
91	BUILDWID	STCK2	29.12	0.00	0.00	0.00	0.00	0.00
92								
93	BUILDLEN	VENT	0.00	0.00	0.00	0.00	0.00	14.08
94	BUILDLEN	VENT	19.35	24.04	28.00	31.11	33.27	34.42
95	BUILDLEN	VENT	34.52	0.00	0.00	0.00	0.00	0.00
96	BUILDLEN	VENT	0.00	0.00	0.00	0.00	0.00	14.08
97	BUILDLEN	VENT	19.35	24.04	28.00	31.11	33.27	34.42
98	BUILDLEN	VENT	34.52	0.00	0.00	0.00	0.00	0.00
99								
100	BUILDLEN	STCK2	0.00	0.00	0.00	0.00	0.00	0.00
101	BUILDLEN	STCK2	0.00	0.00	0.00	0.00	0.00	0.00
102	BUILDLEN	STCK2	47.05	0.00	0.00	0.00	0.00	0.00
103	BUILDLEN	STCK2	0.00	0.00	0.00	0.00	0.00	0.00
104	BUILDLEN	STCK2	28.75	34.86	39.92	43.76	46.28	47.38
105	BUILDLEN	STCK2	47.05	0.00	0.00	0.00	0.00	0.00
106								
107	XBADJ	VENT	0.00	0.00	0.00	0.00	0.00	-26.39
108	XBADJ	VENT	-31.92	-36.49	-39.95	-42.19	-43.16	-42.81
109	XBADJ	VENT	-41.16	0.00	0.00	0.00	0.00	0.00
110	XBADJ	VENT	0.00	0.00	0.00	0.00	0.00	12.31
111	XBADJ	VENT	12.57	12.45	11.95	11.09	9.89	8.39
112	XBADJ	VENT	6.63	0.00	0.00	0.00	0.00	0.00
113								
114	XBADJ	STCK2	0.00	0.00	0.00	0.00	0.00	0.00
115	XBADJ	STCK2	0.00	0.00	0.00	0.00	0.00	0.00
116	XBADJ	STCK2	12.11	0.00	0.00	0.00	0.00	0.00
117	XBADJ	STCK2	0.00	0.00	0.00	0.00	0.00	0.00
118	XBADJ	STCK2	-45.20	-51.84	-56.91	-60.25	-61.76	-61.39
119	XBADJ	STCK2	-59.16	0.00	0.00	0.00	0.00	0.00
120								
121	YBADJ	VENT	0.00	0.00	0.00	0.00	0.00	18.51
122	YBADJ	VENT	15.48	11.74	7.26	2.97	-1.29	-6.23
123	YBADJ	VENT	-10.98	0.00	0.00	0.00	0.00	0.00
124	YBADJ	VENT	0.00	0.00	0.00	0.00	0.00	-18.51
125	YBADJ	VENT	-15.48	-11.74	-7.26	-2.97	1.29	6.23
126	YBADJ	VENT	10.98	0.00	0.00	0.00	0.00	0.00
127								
128	YBADJ	STCK2	0.00	0.00	0.00	0.00	0.00	0.00
129	YBADJ	STCK2	0.00	0.00	0.00	0.00	0.00	0.00
130	YBADJ	STCK2	13.07	0.00	0.00	0.00	0.00	0.00
131	YBADJ	STCK2	0.00	0.00	0.00	0.00	0.00	0.00
132	YBADJ	STCK2	24.65	19.81	14.36	8.48	1.64	-5.80
133	YBADJ	STCK2	-13.07	0.00	0.00	0.00	0.00	0.00
134								
135								

** Variable Emissions Type: "By Hour-of-Day (HROFDY) "

** Variable Emission Scenario: "HrOfDay-LBug20"

138	EMISFACT	BOWS1	HROFDY	0.0	0.0	0.0	0.0	0.0	0.19
139	EMISFACT	BOWS1	HROFDY	0.227	0.235	0.227	0.235	0.248	0.248
140	EMISFACT	BOWS1	HROFDY	0.235	0.231	0.243	0.254	0.254	0.239
141	EMISFACT	BOWS1	HROFDY	0.0	0.0	0.0	0.0	0.0	0.0
142	EMISFACT	BOWS2	HROFDY	0.0	0.0	0.0	0.0	0.0	0.19
143	EMISFACT	BOWS2	HROFDY	0.227	0.235	0.227	0.235	0.248	0.248
144	EMISFACT	BOWS2	HROFDY	0.235	0.231	0.243	0.254	0.254	0.239
145	EMISFACT	BOWS2	HROFDY	0.0	0.0	0.0	0.0	0.0	0.0
146	EMISFACT	BOWS3	HROFDY	0.0	0.0	0.0	0.0	0.0	0.19



147	EMISFACT	BOWS3	HROFDY	0.227	0.235	0.227	0.235	0.248	0.248		
148	EMISFACT	BOWS3	HROFDY	0.235	0.231	0.243	0.254	0.254	0.239		
149	EMISFACT	BOWS3	HROFDY	0.0	0.0	0.0	0.0	0.0	0.0		
150	EMISFACT	BOWS4	HROFDY	0.0	0.0	0.0	0.0	0.0	0.19		
151	EMISFACT	BOWS4	HROFDY	0.227	0.235	0.227	0.235	0.248	0.248		
152	EMISFACT	BOWS4	HROFDY	0.235	0.231	0.243	0.254	0.254	0.239		
153	EMISFACT	BOWS4	HROFDY	0.0	0.0	0.0	0.0	0.0	0.0		
154											
155	** Variable	Emissions Type: "By Hour / Seven Days (HRDOW7)"									
156	** Variable	Emission Scenario: "LBUG20 Vent"									
157	EMISFACT	VENT	HRDOW7	0.0	0.0	0.0	0.0	0.0	0.267	0.0	
158	EMISFACT	VENT	HRDOW7	0.0	0.0	0.0	0.0	0.0	0.267	0.0	0.0
159	EMISFACT	VENT	HRDOW7	0.0	0.0	0.0	0.0	0.0	0.0	0.0	0.0
160	EMISFACT	VENT	HRDOW7	0.0	0.0	0.0	0.0	0.0	0.0	0.0	0.267
161	EMISFACT	VENT	HRDOW7	0.0	0.0	0.0	0.0	0.0	0.0	0.267	0.0
162	EMISFACT	VENT	HRDOW7	0.0	0.0	0.0	0.0	0.0	0.0	0.0	0.0
163	EMISFACT	VENT	HRDOW7	0.0	0.0	0.0	0.0	0.0	0.0	0.0	0.0
164	EMISFACT	VENT	HRDOW7	0.267	0.0	0.0	0.0	0.0	0.0	0.0	0.267
165	EMISFACT	VENT	HRDOW7	0.0	0.0	0.0	0.0	0.0	0.0	0.0	0.0
166	EMISFACT	VENT	HRDOW7	0.0	0.0	0.0	0.0	0.0	0.0	0.0	0.0
167	EMISFACT	VENT	HRDOW7	0.0	0.267	0.0	0.0	0.0	0.0	0.0	0.0
168	EMISFACT	VENT	HRDOW7	0.267	0.0	0.0	0.0	0.0	0.0	0.0	0.0
169	EMISFACT	VENT	HRDOW7	0.0	0.0	0.0	0.0	0.0	0.0	0.0	0.0
170	EMISFACT	VENT	HRDOW7	0.0	0.0	0.267	0.0	0.0	0.0	0.0	0.0
171	EMISFACT	VENT	HRDOW7	0.0	0.267	0.0	0.0	0.0	0.0	0.0	0.0
172	EMISFACT	VENT	HRDOW7	0.0	0.0	0.0	0.0	0.0	0.0	0.0	0.0
173	EMISFACT	VENT	HRDOW7	0.0	0.0	0.0	0.267	0.0	0.0	0.0	0.0
174	EMISFACT	VENT	HRDOW7	0.0	0.0	0.0	0.0	0.0	0.0	0.0	0.0
175	EMISFACT	VENT	HRDOW7	0.0	0.0	0.0	0.0	0.0	0.0	0.0	0.0
176	EMISFACT	VENT	HRDOW7	0.0	0.0	0.0	0.0	0.267	0.0	0.0	0.0
177	EMISFACT	VENT	HRDOW7	0.0	0.0	0.0	0.0	0.0	0.0	0.0	0.0
178											
179	** Variable	Emissions Type: "By Hour-of-Day (HROFDY)"									
180	** Variable	Emission Scenario: "HrOfDay-Adjacent"									
181	EMISFACT	VOL1	HROFDY	0.0	0.0	0.0	0.0	0.0	0.102		
182	EMISFACT	VOL1	HROFDY	0.122	0.127	0.122	0.127	0.133	0.133		
183	EMISFACT	VOL1	HROFDY	0.127	0.125	0.131	0.137	0.137	0.129		
184	EMISFACT	VOL1	HROFDY	0.0	0.0	0.0	0.0	0.0	0.0		
185	EMISFACT	VOL2	HROFDY	0.0	0.0	0.0	0.0	0.0	0.102		
186	EMISFACT	VOL2	HROFDY	0.122	0.127	0.122	0.127	0.133	0.133		
187	EMISFACT	VOL2	HROFDY	0.127	0.125	0.131	0.137	0.137	0.129		
188	EMISFACT	VOL2	HROFDY	0.0	0.0	0.0	0.0	0.0	0.0		
189	EMISFACT	VOL3	HROFDY	0.0	0.0	0.0	0.0	0.0	0.102		
190	EMISFACT	VOL3	HROFDY	0.122	0.127	0.122	0.127	0.133	0.133		
191	EMISFACT	VOL3	HROFDY	0.127	0.125	0.131	0.137	0.137	0.129		
192	EMISFACT	VOL3	HROFDY	0.0	0.0	0.0	0.0	0.0	0.0		
193											
194	** Variable	Emissions Type: "By Hour / Seven Days (HRDOW7)"									
195	** Variable	Emission Scenario: "Adjacent Vent"									
196	EMISFACT	STCK2	HRDOW7	0.0	0.0	0.0	0.0	0.0	0.178	0.0	
197	EMISFACT	STCK2	HRDOW7	0.0	0.0	0.0	0.0	0.0	0.178	0.0	0.0
198	EMISFACT	STCK2	HRDOW7	0.0	0.0	0.0	0.0	0.0	0.0	0.0	0.0
199	EMISFACT	STCK2	HRDOW7	0.0	0.0	0.0	0.0	0.0	0.0	0.0	0.178
200	EMISFACT	STCK2	HRDOW7	0.0	0.0	0.0	0.0	0.0	0.0	0.178	0.0
201	EMISFACT	STCK2	HRDOW7	0.0	0.0	0.0	0.0	0.0	0.0	0.0	0.0
202	EMISFACT	STCK2	HRDOW7	0.0	0.0	0.0	0.0	0.0	0.0	0.0	0.0
203	EMISFACT	STCK2	HRDOW7	0.178	0.0	0.0	0.0	0.0	0.0	0.0	0.178
204	EMISFACT	STCK2	HRDOW7	0.0	0.0	0.0	0.0	0.0	0.0	0.0	0.0
205	EMISFACT	STCK2	HRDOW7	0.0	0.0	0.0	0.0	0.0	0.0	0.0	0.0
206	EMISFACT	STCK2	HRDOW7	0.0	0.178	0.0	0.0	0.0	0.0	0.0	0.0
207	EMISFACT	STCK2	HRDOW7	0.178	0.0	0.0	0.0	0.0	0.0	0.0	0.0
208	EMISFACT	STCK2	HRDOW7	0.0	0.0	0.0	0.0	0.0	0.0	0.0	0.0
209	EMISFACT	STCK2	HRDOW7	0.0	0.0	0.178	0.0	0.0	0.0	0.0	0.0
210	EMISFACT	STCK2	HRDOW7	0.0	0.178	0.0	0.0	0.0	0.0	0.0	0.0
211	EMISFACT	STCK2	HRDOW7	0.0	0.0	0.0	0.0	0.0	0.0	0.0	0.0
212	EMISFACT	STCK2	HRDOW7	0.0	0.0	0.0	0.178	0.0	0.0	0.0	0.0
213	EMISFACT	STCK2	HRDOW7	0.0	0.0	0.0	0.0	0.0	0.0	0.0	0.0
214	EMISFACT	STCK2	HRDOW7	0.0	0.0	0.0	0.0	0.0	0.0	0.0	0.0
215	EMISFACT	STCK2	HRDOW7	0.0	0.0	0.0	0.0	0.178	0.0	0.0	0.0
216	EMISFACT	STCK2	HRDOW7	0.0	0.0	0.0	0.0	0.0	0.0	0.0	0.0
217	SRCGROUP	Adjacent	VOL1	VOL2	VOL3	STCK2					
218	SRCGROUP	LBUG20	BOWS1	BOWS2	BOWS3	BOWS4	VENT				
219	SRCGROUP	ALL									



```

220 SO FINISHED
221 **
222 *****
223 ** AERMOD Receptor Pathway
224 *****
225 **
226 **
227 RE STARTING
228     INCLUDED CCare.rou
229 RE FINISHED
230 **
231 *****
232 ** AERMOD Meteorology Pathway
233 *****
234 **
235 **
236 ME STARTING
237     SURFFILE 22025.SFC
238     PROFFILE 22025.PFL
239     SURFDATA 0 2020
240     UAIRDATA 0 2020
241     SITEDATA 0 2020
242     PROFBASE 7.0 METERS
243 ME FINISHED
244 **
245 *****
246 ** AERMOD Output Pathway
247 *****
248 **
249 **
250 OU STARTING
251     RECTABLE ALLAVE 1ST
252     RECTABLE 1 1ST
253     RECTABLE 24 1ST
254 ** Auto-Generated Plotfiles
255     PLOTFILE 1 ALL 1ST CCARE.AD\01H1GALL.PLT 31
256     PLOTFILE 24 ALL 1ST CCARE.AD\24H1GALL.PLT 32
257     PLOTFILE 1 Adjacent 1ST CCARE.AD\01H1G001.PLT 33
258     PLOTFILE 24 Adjacent 1ST CCARE.AD\24H1G001.PLT 34
259     PLOTFILE 1 LBug20 1ST CCARE.AD\01H1G002.PLT 35
260     PLOTFILE 24 LBug20 1ST CCARE.AD\24H1G002.PLT 36
261     PLOTFILE ANNUAL ALL CCARE.AD\AN00GALL.PLT 37
262     PLOTFILE ANNUAL Adjacent CCARE.AD\AN00G001.PLT 38
263     PLOTFILE ANNUAL LBug20 CCARE.AD\AN00G002.PLT 39
264     SUMMFILE CCare.sum
265 OU FINISHED
266 **
267 *****
268 ** Project Parameters
269 *****
270 ** PROJCTN  CoordinateSystemUTM
271 ** DESCPTN  UTM: Universal Transverse Mercator
272 ** DATUM    World Geodetic System 1984
273 ** DTMRGN  Global Definition
274 ** UNITS   m
275 ** ZONE    -50
276 ** ZONEINX 0
277 **
278

```

